



Universal 1-channel switching receiver EnOcean Easyfit RCM 250

User Manual V1.16
October 2009

Revision History

The following major modifications and improvements have been made to the initial version of the document (User Manual V1.0):

Version	Subject (major changes since last version)
V1.1	Relay output switching capabilities added (chapter 1.5)
V1.11	Power dissipation added
V1.12	Relay switching capability corrected
V1.13	Declaration of conformity added
V1.14	Editorial changes
V1.15	Editorial changes
V1.16	CE declaration replaced by link to website

Published by EnOcean GmbH, Kolpingring 18a, 82041 Oberhaching, Germany

www.enocean.com, info@enocean.com, phone ++49 (89) 6734 6890

© EnOcean GmbH, All Rights Reserved

Important!

This information describes the type of component and shall not be considered as assured characteristics. No responsibility is assumed for possible omissions or inaccuracies. Circuitry and specifications are subject to change without notice. For the latest product specifications, refer to the EnOcean website: <http://www.enocean.com>.

As far as patents or other rights of third parties are concerned, liability is only assumed for modules, not for the described applications, processes and circuits.

EnOcean does not assume responsibility for use of modules described and limits its liability to the replacement of modules determined to be defective due to workmanship. Devices or systems containing RF components must meet the essential requirements of the local legal authorities. The approval requirements described in this document are of best knowledge without any warranty.

The modules must not be used in any relation with equipment that supports, directly or indirectly, human health or life or with applications that can result in danger for people, animals or real value.

Components of the modules are considered and should be disposed of as hazardous waste. Local government regulations are to be observed.

Packing: Please use the recycling operators known to you. By agreement we will take packing material back if it is sorted. You must bear the costs of transport. For packing material that is returned to us unsorted or that we are not obliged to accept, we shall have to invoice you for any costs incurred.

Table of Contents

1. GENERAL DESCRIPTION	4
1.1 Basic Functionalities	4
1.2 Typical Applications	4
1.3 Features Overview	5
1.4 Physical Outline Dimensions	6
1.5 Relay output switching capabilities	8
1.6 Terminal Block Description	9
1.7 Environmental Conditions	9
1.8 Ordering Information	9
2. FUNCTIONAL DESCRIPTION	10
2.1 Block Diagram	10
2.2 Connector Description	10
2.3 Operating Mode	11
2.4 Learning of Radio Transmitters	11
2.5 Selective Deleting	12
2.6 Clear All	12
3. APPLICATIONS INFORMATION	13
3.1 Installation	13
3.2 Mounting RCM 250 Near To Metallic Objects	14
3.3 Transmission Range	14
3.4 CE Approval Requirements	15
3.5 Product Safety	16
3.6 Field Intensity Meter EPM 100	16
4. DECLARATION OF CONFORMITY	17

1. GENERAL DESCRIPTION

The **1-channel switching receiver RCM 250** is controlled by radio signals from EnOcean transmitters and serves to switch various electronic loads such as incandescent lamps, high-voltage halogen lamps, electronic ballast and inductive loads. Each transmitter can simultaneously control an unlimited number of receivers. Each transmitter has its own fixed address and has to be assigned to the RCM receiver.

1.1 Basic Functionalities

Each receiver can be assigned, either a maximum of 30 EnOcean PTM radio switches, or up to 2 EnOcean STM 250 radio window contacts. Learning of mixed PTM and STM transmitters is not possible. The memory of the receiver is empty when delivered. By assigning the first transmitter the operating mode is defined. The operating mode can only be changed after deleting all learned transmitters with the CLR button.

- a) Mode **ROCKER SWITCH**: Each assigned PTM transmitter can be used to change the switching state of the receiver. It is possible to switch ON (button I) with one switch and OFF (button O) with another switch. When learning a radio switch only the rocker which has been operated is assigned to the receiver.
- b) Mode **WINDOW CONTACT**: If at least one of the assigned STM 250 window contacts is open the switching state of the receiver is ON. If both contacts are closed the state is OFF. The radio window contacts are transmitting a life signal approx. every 15min. 60 min after reception of the last life signal the receiver considers this contact to be closed.



Figure 1: 1-channel switching receiver RCM250

1.2 Typical Applications

- **Building installation**
- **Industrial automation**
- **Consumer Electronics**

The RCM switching receiver is part of a powerful RF system solution from EnOcean for operation and control applications. Because the RF transmitters are self-powered (no batteries), maintenance-free RF systems can be implemented.

The RCM switching receiver operates together with the following further EnOcean components: PTM (batteryless radio switches), STM 250 (batteryless radio window contact), CTM (remote control) and TCM (bi-directional IT interface)

1.3 Features Overview

Power Supply:	230 VAC, 50 Hz
Power Dissipation:	0.9 W typ.
Relay Output:	Maximum Load: 1100VA resistive ($\cos\phi=1$) 400W tungsten (incandescent lamp), 360W ballast with $\cos\phi=0.4-0.6$ (fluorescent lamp)
No. of Relay switching operations:	40.000 actuations min.
Radio Frequency:	868.3 MHz (stabilized by crystal PLL)
Antenna:	internal whip antenna
Channel Bandwidth / Sensitivity:	280 kHz / -95 dBm
Control Inputs:	2 pushbuttons LRN (set receiver into learning mode) and CLR (clear all)
Learning Mode Indication:	acoustic feedback (switching noise of relais)
Number of RF transmitters learnable:	up to 30 switches or up to 2 magnet contacts
Note: either PTMs or either STM250s can be learned, not mixed (for priority reasons)	

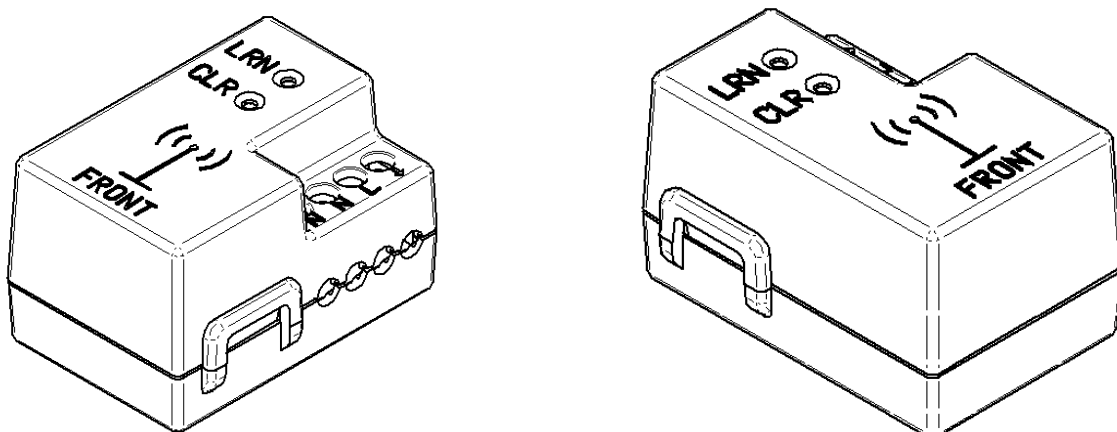

Figure 2: RCM 250 housing

1.4 Physical Outline Dimensions

Dimensions of housing: 47.4 x 34.6 x 28.8 mm

Tolerance values of the following 3 outline drawings: +/- 0.2 mm

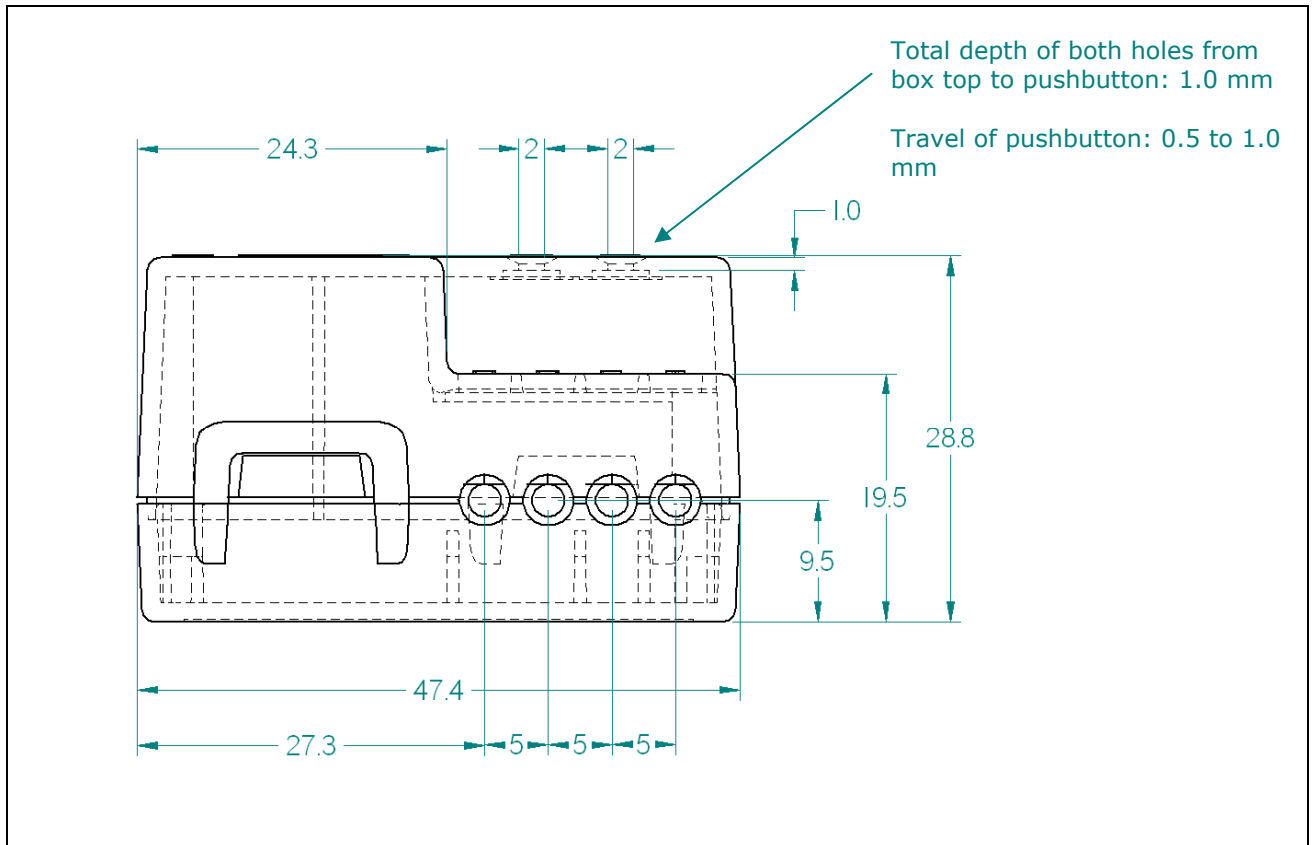

Figure 3: RCM 250 side view

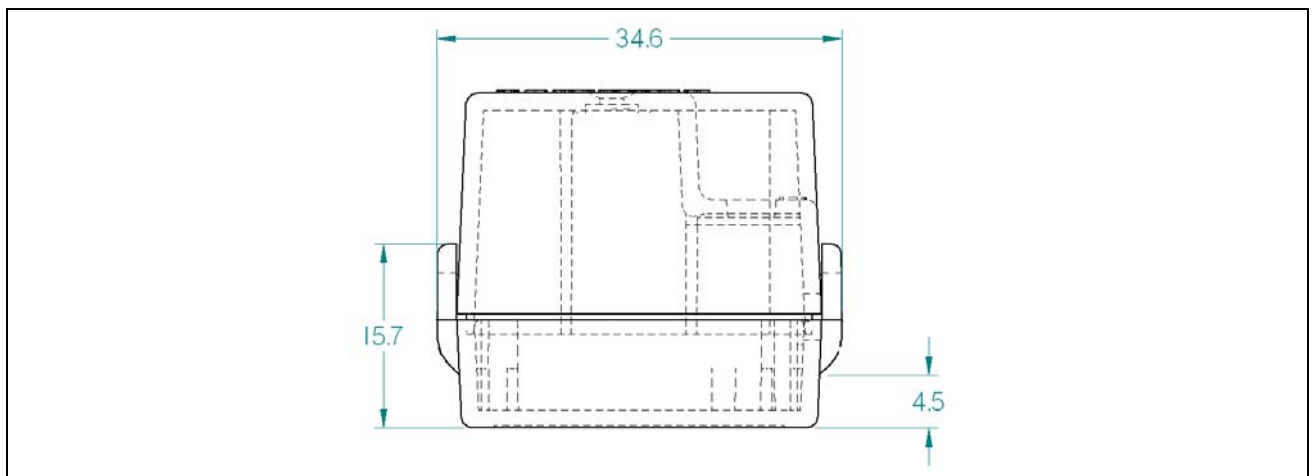

Figure 4: RCM 250 front view

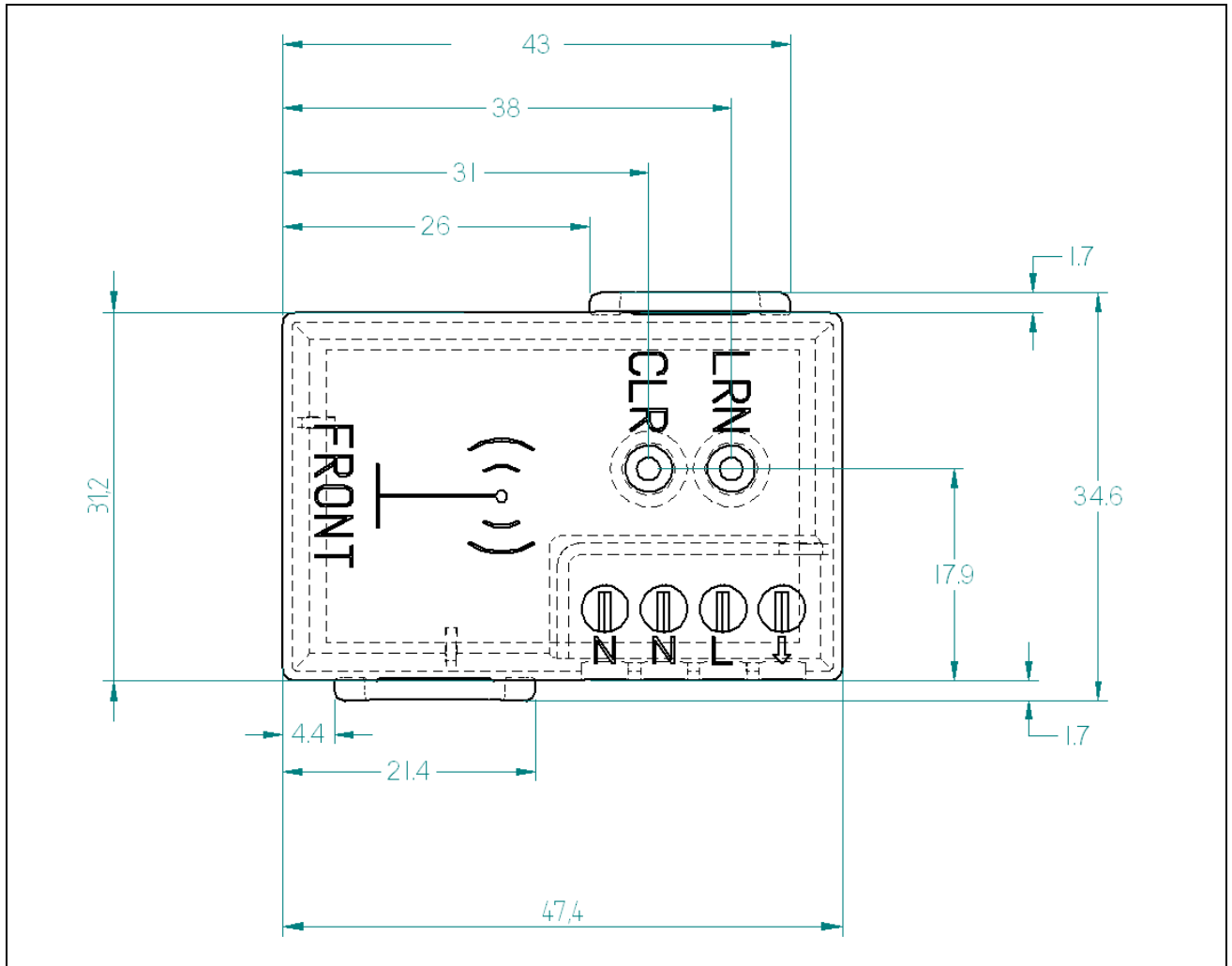

Figure 5: RCM 250 top view

1.5 Relay output switching capabilities

Kind of load		Maximum Load	Electrical life
Incandescent lamp 230V AC		4 x 100W	20.000 (according to EN60669)
Gas discharge lamps / HQL-HQI / not compensated*		100W	20.000
Gas discharge lamps / HQL-HQI / compensated*		80W (14 μ F)	20.000
EVG Dynamic / dimmer*		4 x 18W 3 x 36W 2 x 58W	25.000
Halogen lamp 230V AC		150W	20.000
Fluorescent lamp 230V AC with conventional ballasts	Not compensated $\cos\phi$ 0,4 – 0,6	20 x 18W	25.000
		10 x 36W	25.000
		6 x 58W	25.000
	Compensated with capacitance in parallel	4 x 18W	20.000
		3 x 36W	20.000
		2 x 58W (2x7 μ F)	20.000
		Compensated fluorescent DUO-circuit	4 x 18W 3 x 36W 2 x 58W
Fluorescent lamp 230V AC with electronic ballasts	Siemens / Osram EVG	6 x 18W	20.000
		4 x 36W	20.000
		3 x 58W	20.000
Resistive load 230V AC	$\cos\phi=1$	5A	Min. 50.000
Max. capacitance at 230V AC		14 μ F	Min. 5.000 (according to EN60669)
Max. inrush current for max. 20ms at 230V AC		40 A	see above loads

1.6 Terminal Block Description

Terminal Block: 4 pole, terminal screw with wire guard
Rated torque/ screw size: 0,4 Nm / M2,6
Max. rated cross section - Single wire (solid): 1.5 mm²
Max. rated cross section - Stranded wire (flex.): 1.0 mm²
Max. rated cross section - Stranded wire with ferrules:0.75 mm²

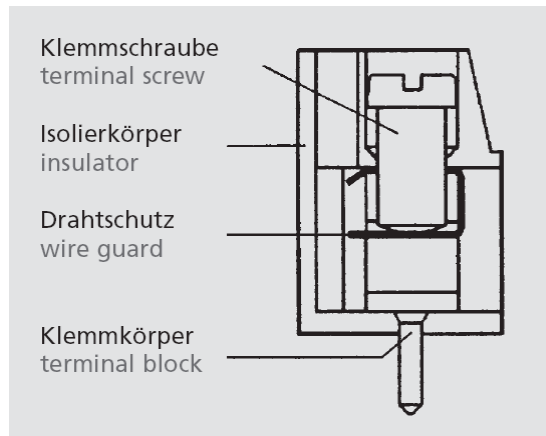

Figure 6: RCM 250 terminal block

1.7 Environmental Conditions

Operating Temperature:..... -10 up to +45 °C
Storage Temperature:..... -25 up to +80 °C
Humidity:..... 0 % to 95 % r.h., no condensing

1.8 Ordering Information

Type	EnOcean Ordering Code	Remarks
RCM 250	H5002-B250	230 VAC / 50Hz

2. FUNCTIONAL DESCRIPTION

2.1 Block Diagram

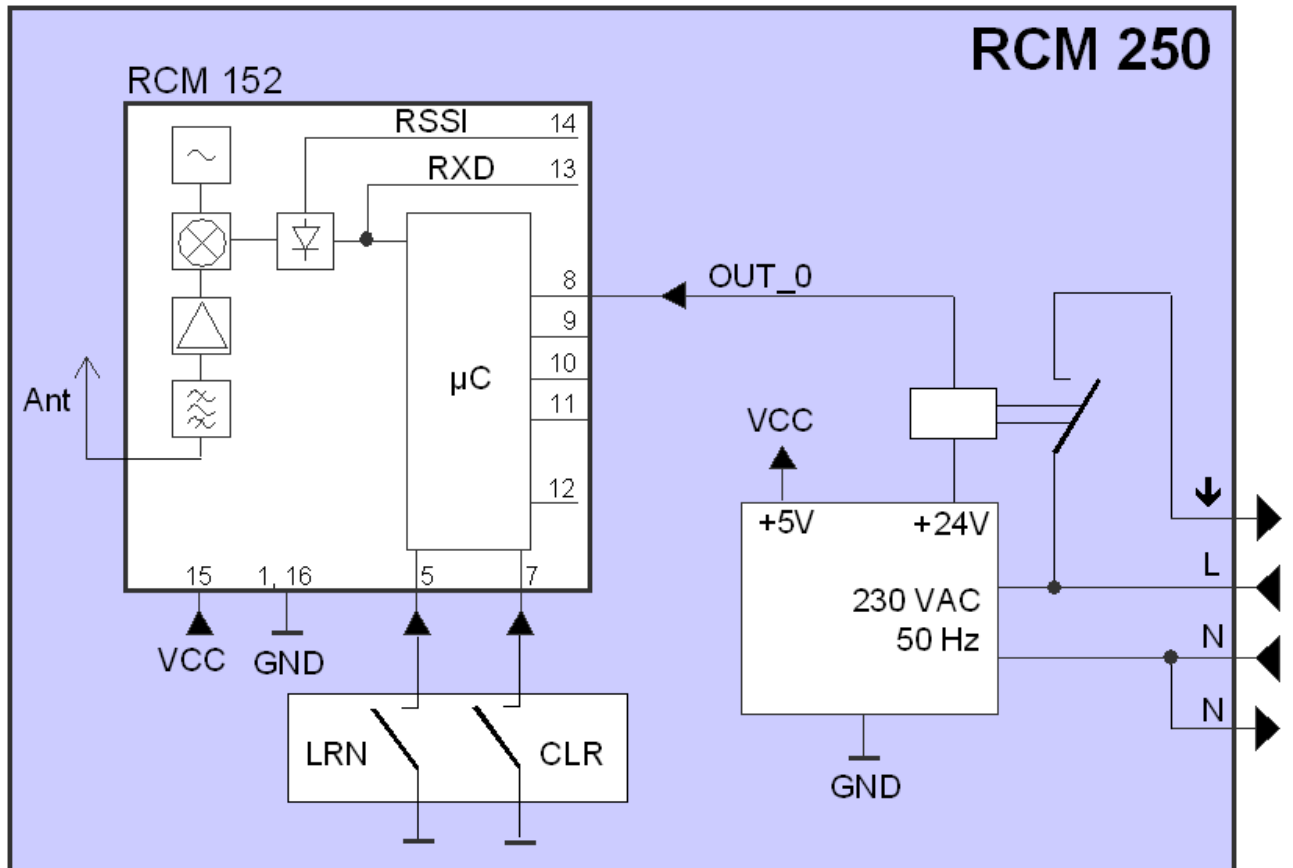

Figure 7: Block diagram of RCM 250

2.2 Connector Description

Symbol	Function	Operational characteristics
↓	Load	Relays output switched to Hot
L	Hot	Power Supply 230 VAC, 50 Hz
N	Neutral	Power Supply 230 VAC, 50 Hz
N	Neutral	Internally coupled to second N connector

2.3 Operating Mode

Each RCM 250 can operate as either a Push Button Switch receiver (by LEARNING EnOcean PTM 250 Switches) or a Magnet Contact Receiver (by LEARNING EnOcean STM 250 magnet contacts), but not a mix of devices. The RCM 250 can LEARN either a maximum of 30 EnOcean PTM 250's or up to 2 EnOcean STM 250s. The memory of the receiver is empty when delivered. By assigning the first transmitter the operating mode (push button switch or magnet contact) is defined. The operating mode can only be changed after deleting all learned transmitters with the CLR button.

a) Mode ROCKER SWITCH: Each assigned transmitter can be used to change the switching state of the receiver. It is possible to switch ON (button I) with one switch and OFF (button O) with another switch. When learning a radio switch with 2-rockers, only the rocker which has been pressed is learned by the receiver.

Initialization: After Power-up and Learning Phase the relays output is open ("off"). At least one of the learned radio switches have to be operated to switch the output.

b) Mode WINDOW CONTACT: If at least one of the assigned window contacts is open the switching state of the receiver is ON. If both contacts are closed the state is OFF.

Time Out: The radio window contacts transmit a 'supervisory signal' typically every 15 min (5...30 min). The receiver considers this contact to be closed if there has been no life signal for more than 60 ($\pm 10\%$) minutes. Some possible causes for this fail function: The energy store of the window contact is empty, the radio channel is disturbed, the window contact has been removed, or the contact is broken.

Initialization: After Power-up and Learning Phase the module output OUT_0 is inactive ("off"). At least one of the learned magnet contacts have to be opened to release the output immediately (before first incoming presence signal).

2.4 Learning of Radio Transmitters

- 1.) For programming the RCM255 must be connected to power. The programming is retained when power is disconnected. To prevent LEARNING unintentional switches, when in learn mode, the receiver sensitivity is reduced to approximately 5 meters from the switch.
- 2.) Operating the LRN or CLR pushbutton should be done by pushing a non-metallic insulated probe (e.g. ballpoint pen) carefully through the small hole in the housing onto the pushbutton behind.
- 3.) Press the button LRN and hold it down. After 0.3 s programming mode becomes active confirmed by 1 second cyclic switching of the output relays ("Toggling"): A light connected to the power output will be switched on and off every second. In quiet environments the toggling of the relay can be heard.
- 4.) Transmitters can now be assigned: By pressing one of the rockers of a PTM radio switch or by pressing the learn button inside the back cover of the STM250 magnet contact, the transmitter is assigned to the switching receiver, and the relay stops toggling for

about 4 seconds. The relay status confirms that the transmitter has been saved (contact 4s on) or an already learned transmitter is deleted (contact 4s off).

- 5.) As soon as the toggling of the relays continues, another transmitter can be assigned or deleted. If the memory is full (30 EnOcean PTM 250 radio switches or 2 EnOcean STM 250 radio window contacts) the receiver goes into operating mode during an attempt to enter a further transmitter. In this case at least one ID has to be deleted before entering a new transmitter.
- 6.) Programming mode is left by re-pressing the LRN button, or after 30 seconds of no activity the receiver exits programming mode automatically.

2.5 Selective Deleting

A transmitter that has been assigned can be selectively deleted. The programming mode is activated by pressing the LRN button. Then actuate the rocker or learn button of a previously learned transmitter, it is now unlearned. Programming mode is left manually by repressing the LRN button.

2.6 Clear All

If the CLR key is pressed and held for approx. 2 seconds the memory is deleted completely (condition upon delivery). Then the switching receiver changes to programming mode which is signaled by the toggling output relays. Programming mode is left manually by pressing the LRN button.

3. APPLICATIONS INFORMATION

3.1 Installation

- 1.) **WARNING:** To avoid fire, shock, or death: **TURN OFF POWER** at circuit breaker or fuse and test that power is off before wiring!
- 2.) For in-wall mounting an outlet box of 40mm minimum depth must be used. For best performance do not mount the receivers close to the floor or near to wall niches.
- 3.) Prepare wires: Make sure that the ends of the wires from the LINE and the LOAD are straight (cut if necessary). Remove about 7mm of insulation from each wire.
- 4.) Connect wires per EXAMPLE CIRCUIT as shown in figure 6. The both N clamps are coupled internally. Use an insulated electrician screw driver with suited tip size.
- 5.) Installation may now be completed by carefully positioning all wires and stowing the receiver box. Restore power.

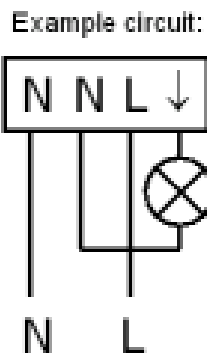

Figure 8: RCM 250 Example Circuit

The integrated $\frac{1}{4}$ -wave whip antenna enables a very compact receiver unit with good radio reception characteristics. **For good receiver performance take attention to the factors restricting transmission range mentioned in the next both chapters.**

Please note that the **best range can be received by facing EnOcean transmitters to the RCM 250 receiver casement top position** (see antenna marking on cap). This is a result of the internal antenna position that can be seen in the following picture:

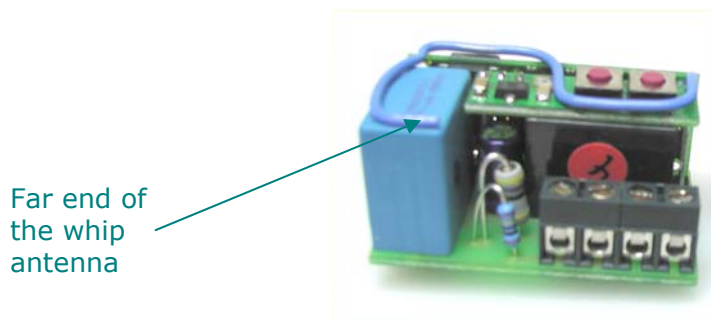

Figure 9: Internal position of the RCM 250 whip antenna

3.2 Mounting RCM 250 Near To Metallic Objects

For range performance a minimum distance of 1 cm, better 2 cm, should be given from the whole length of the antenna to any conductive objects. Mainly the far end of the whip should be mounted as far away as possible from all metal parts.

The internal position of the antenna is shown in Figure 9.

Please note that large metallic parts or conductive objects in the transmission direction causes shading of the radio waves that could result in range reduction. Using a suited placed repeater is a prospective remedial measure.

Do not mount the receiver into an enclosed metal housing.

3.3 Transmission Range

Since the radio signals are electromagnetic waves, the signal is attenuated on the way from the transmitter to the receiver. This means that the field intensity diminishes as the distance between the transmitter and the receiver increases, and radio range is restricted. Obstacles between devices can also reduce the range.

In practice, this means that the materials used in the building play an important role when an assessment of the radio range is made. Some standard values for helping in assessing the environment:

- **Line-of-sight connections:** Typically 30m range in corridors, up to 100m in halls
- **Plasterboard walls / dry wood:** Typically 30m range, through max. 5 walls
- **Brick walls / aerated concrete:** Typically 20m range, through max. 3 walls
- **Ferroconcrete walls / ceilings:** Typically 10m range, through max. 1 ceiling
- **Fire-safety walls, elevator shafts, staircases and supply areas should be considered as screening.**

Other factors restricting transmission range:

- **Switch mounted on metal surfaces (up to 30% loss of transmission range)**
- **Hollow lightweight walls filled with insulating wool on metal foil**
- **False ceilings with panels of metal or carbon fiber**
- **Lead glass or glass with metal coating, steel furniture**
- **Mounting transmitter or receiver on the floor, or close to the floor, or at wall niches**
- **Humidity in materials**
- **Devices transmitting RF signals such as computers, audio and video equipment, or electronic gear controls for lamps. A minimum distance of 0.5m should be kept**

The angle at which the transmitted signal hits the wall is very important. The effective wall thickness – and with it the signal attenuation – varies according to this angle. Signals should be transmitted as directly as possible through the wall. Wall niches should be avoided.

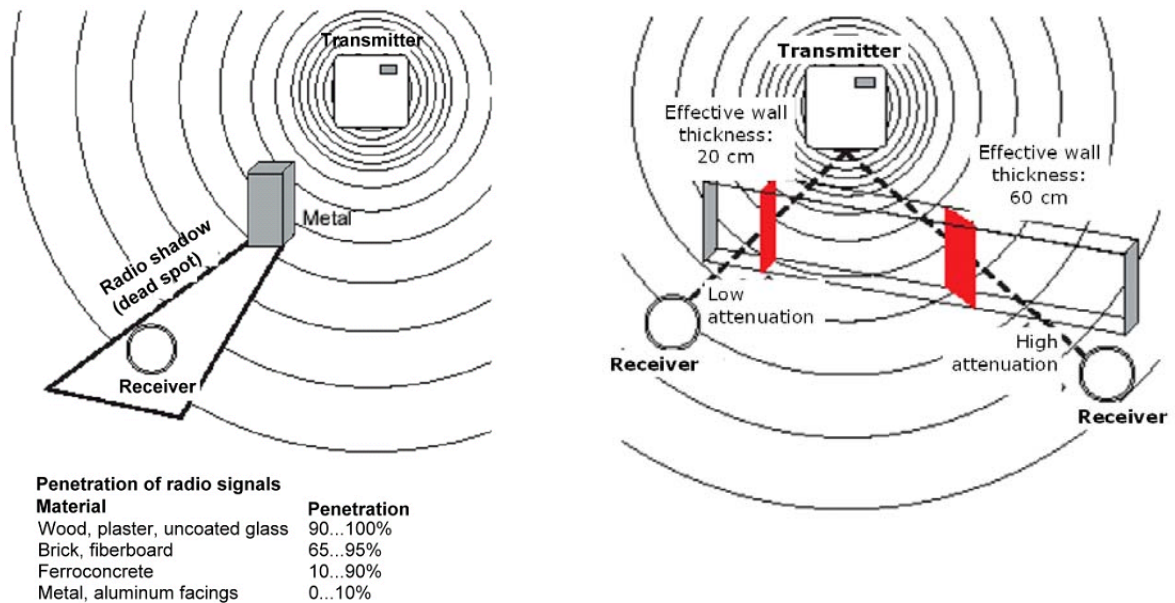

Figures 10 and 11: Obstacles reducing the transmission range

3.4 CE Approval Requirements

The devices bear the EC conformity marking CE and conform to the R&TTE EU-directive on radio equipment. The assembly conforms to the European and national requirements of electromagnetic compatibility. The conformity has been proven and the corresponding documentation has been deposited at EnOcean. **The EnOcean 868 MHz radio devices can be operated without notification and free of charge in the area of the European Union, in Switzerland, in Croatia, in Cyprus, in Czech, in Estonia, in Hungary, in Latvia, in Lithuania, in Malta, in Poland, in Romania and in Slovenia.** The following provisos apply:

- EnOcean RF devices must not be modified or used outside their specification limits.
- EnOcean RF devices may only be used to transfer digital or digitized data. Analog speech and/or music are not permitted.
- The final product incorporating EnOcean RF devices must itself meet the essential requirement of the R&TTE Directive and a CE marking must be affixed on the final product and on the sales packaging each. Operating instructions containing a Declaration of Conformity has to be attached.
- If transmitters are used according to the regulations of the 868.3 MHz band, a so-called "Duty Cycle" of 1% per hour for each transmitter must not be exceeded. Permanent transmitters are not allowed. For conventional applications, it must be ensured that
 - a) the **PTM radio device is not operated more than 6000 times within one hour** (one operation: energy bow is pressed and released). Within this calculation, the extraordinary short telegram

length is considered including three subtelegrams (see Chapter 2.3.3). Also a tolerance of 5% in the telegram length is included.

- b) the **STM 250 reed contact is not operated more than 13.000 times per hour** (e.g. window opened or window closed). For this calculation the extraordinary short telegram length is considered including all subtelegrams (see Chapter 2.3.3). Also a tolerance of 5% in telegram length is included.

3.5 Product Safety

This device complies with EN 60669. The conformity has been proven by a notified body.

3.6 Field Intensity Meter EPM 100

The EPM100 is a mobile field-intensity meter that helps the engineer to find the best installation positions for sensor and receiver. It can also be used to check disturbances in links to already installed equipment.

The EPM100 displays the field intensity of received radio telegrams and interfering radio signals in the 868MHz range.

The simplest procedure for determining the best installation positions for the radio sensor/receiver:

- Person 1 operates the radio sensor and generates pushbutton radio telegrams.
- Person 2 checks the received field intensity on the meter display to find the optimal installation position.



Figure 12: EPM 100 helps to qualify installation positions



4. DECLARATION OF CONFORMITY

Please find the latest version of our declaration of conformity here:

http://www.enocean.com/en/enocean_modules/rcm-250/