

## DOLPHIN MIGRATION - Replacing RCM 1xy / TCM 1x0 / TCM 2x0C by TCM 3xy(C)

The new transceiver modules TCM 3x0(C) enable the realization of highly efficient, in-system programmable repeaters, transceivers or actuators for both EnOcean 868 and 315 MHz radio systems, with extended temperature range and down to half of the power requirements vs. its predecessors RCM 1xy / TCM 1x0 and TCM 2x0C devices, using a unique platform (Dolphin).

Using a TCM 3x0(C) transceiver, it is easy for every one to implement many already existing EnOcean standard functions like e.g. unidirectional serial communication (TCM 2x0C, RCM 120), bidirectional serial communication (TCM 120), repeater (TCM 110, TCM 2x0C), single/quad switch actuators, dimmer (RCM 110). Therefore a simple mode select function analogue to the RCM 1xy based devices is implemented. Note however that they are some application differences as showed below.

**Note:** This Appnote only shows some major differences between the devices and some easy HW migrations solutions to the TCM 3x0(C) Family. For more details please always carefully consult the correspondently actual user manuals. Please note that the following examples are rough concepts only.

### 1. Some important TCM 3x0(C) features:

- The TCM 3x0(C) has analogue to the RCM 1xy (see Table 1), at start-up an operating mode selection possibility. The operating mode (Table 2) is defined at start-up of the device via reading of the correspondingly voltage level at the ADIO\_0 input.

- Repeater functionality (1 or 2 level) can be activated and selected (at power-up).

- In addition a development environment with a powerful API is available. This allows the development of customer specific firmware, provides functions for chip configuration, transmission and reception, ID, I/O handling, control of power down modes, comfortable Remote Management and other features.

Due to its reduced pin out (16 pins) and similar form factor with the predecessor products, TCM 320(C) offers the easiest and cost effective way for implementation of standard functions, see the following examples.

	Function / Mode
<b>RCM110</b>	Switching mode 1,2,4 channels Dimming mode Scene control
<b>RCM120</b>	Push button mode 1 channel Tubular motor control 1,2 channel Serial interface mode
<b>RCM130</b>	Serial interface mode: -with faster timing -learning of 1BS and 4BS transmitters with LRN bit -deletion of learned transmitter signaled via serial I/F Tubular motor control 1,2 channel Additional "industrial" serial mode: -learning of 1BS and 4BS transmitters also without LRN bit -deletion of learned transmitters only via CLR
<b>RCM140</b>	Push button mode 2 channel
<b>RCM152</b>	Switching mode 1 channel for up to 30 PTM or up to 2 STM 250 No remote learning capability

Table 1: RCM 1xy operating modes

Mode	TCM 3x(C) Function / Mode
0	Unidirectional serial interface, LRN
1	Bidirectional serial interface, LRN
2	Rocker Switch - 1 channel
3	Rocker Switch - 4 channels
4	Dimming - 1 channel
ALL	Switchable Repeater, (1 or 2-level)

Table 2: TCM 3x0(C) operating modes

DOLPHIN MIGRATION -  
Replacing RCM 1xy / TCM 1x0 / TCM 2x0C by TCM 3xy(C)

2. Application examples

**a. Actuator:** one first obvious difference is the lower supply voltage requirements of the new devices. Second, in opposite to RCM 1xy (open collector outputs, up to 35 V, 100 mA) that can direct drive relays, the TCM 3x0(C) has digital outputs. Due to its much lower supply voltage i.e. 2.5 to 3.3 V for the TCM 320(C) and lower output drive capacity (max. 2 mA) external output drivers for power actuators like relays will be required like shown in Fig. 1

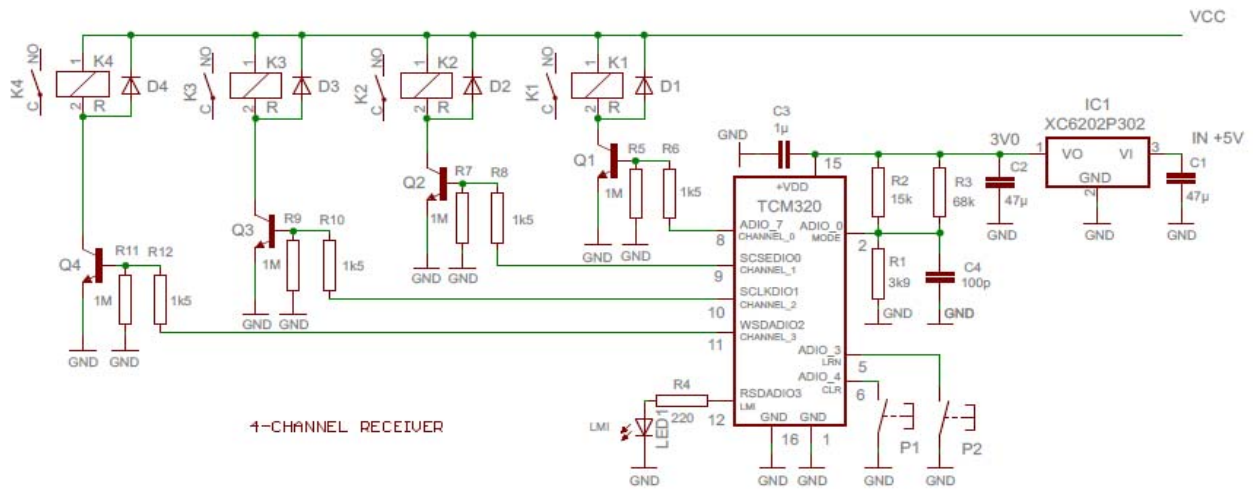

**Fig.1:** 4 channel actuator circuit diagram (Mode 3, switch actuator analogue to similar RCM 110 receiver). Using ADIO\_1 and ADIO\_2 inputs like illustrated in Fig.2 additional repeater functionality can be achieved. Similar (using Mode 2 respectively Mode 4) one channel switch or one channel dimming receiver can be also easy implemented.

**Note:** in the TCM 3x0(C) standard function modes 2, 3, and 4 only RPS or HRC telegrams can be learned.

**b. Repeater:** the example in Fig.2 shows a configurable repeater based on TCM 320(C):

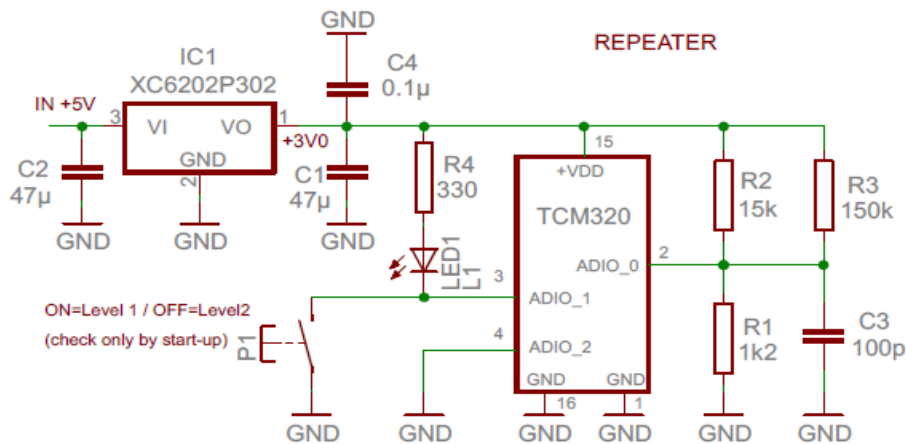

**Fig.2:** Repeater (similar to TCM 110 respectively TCM 2x0C repeater)

DOLPHIN MIGRATION -  
Replacing RCM 1xy / TCM 1x0 / TCM 2x0C by TCM 3xy(C)

**c. Serial Interfaces:** one of the most usual applications of the RCM 120 is as EnOcean serial interface receiver (only), followed by a customer dedicated external microcontroller and driver circuit. This can also be very easy implemented with TCM 3x0(C), a simple example is shown in Fig. 3. The serial output can be further connected to a RS232 interface like shown in the Fig. 4.

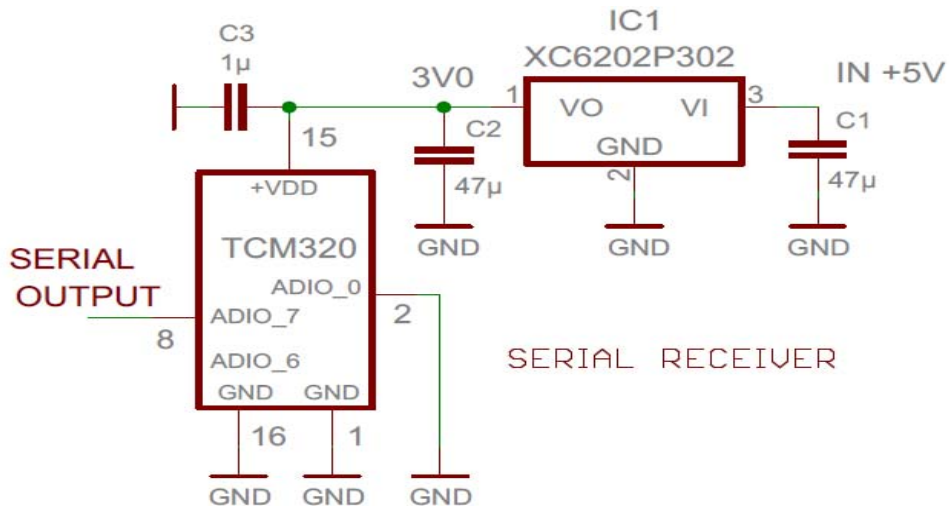

**Fig.3:** Simple (unidirectional) serial interface realized with TCM 320(C). Using ADIO\_1 and ADIO\_2 inputs like illustrated in Fig.2 additional repeater functionality can be achieved.

Fig. 4 shows a TCM 320(C) as a bidirectional RS232 serial interface (Transceiver):

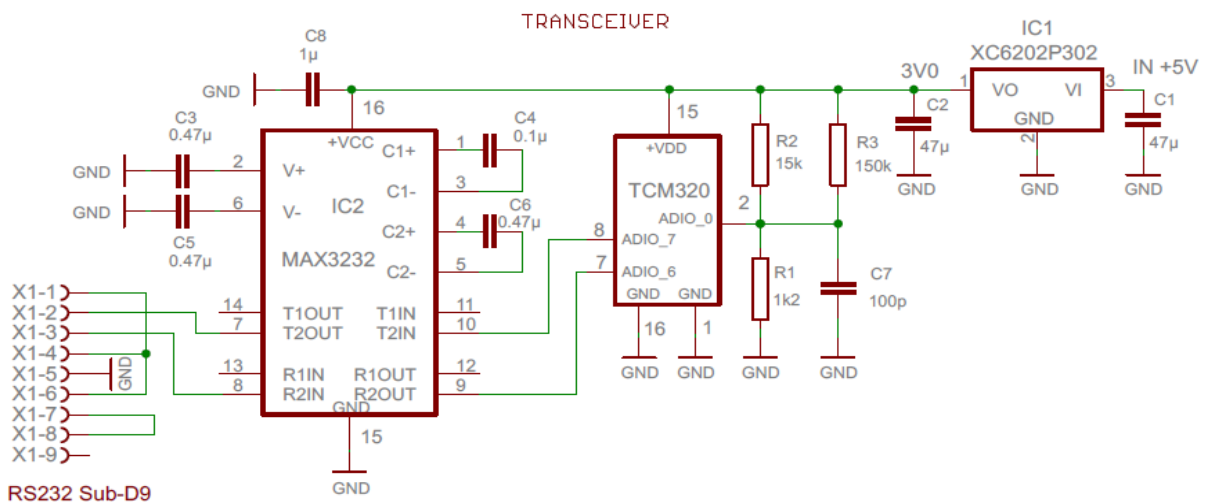

**Fig.4:** RS232 Interface using TCM 320(C), similar to the TCM 120. Using ADIO\_1 and ADIO\_2 inputs like illustrated in Fig.2 additional repeater functionality can be achieved.

**Note:** Other digital interfaces e.g. SPI, I2C are available or can be emulated.

## DOLPHIN MIGRATION - Replacing RCM 1xy / TCM 1x0 / TCM 2x0C by TCM 3xy(C)

### 3. Further general considerations by designing with the TCM3x0(C):

1. In contrast to its predecessors RCM/TCM 1x0, TCM 3x0(C) has no dedicated analog output pin for the received signal strength indication (RSSI) of the radio path. Instead of this it is possible to evaluate and display the internally instantaneous digital RSSI value with appropriate SW tools.
2. A very useful, flexible and powerful tool for Evaluation and Development of the new Dolphin based modules is the new EDK 300(C) (EnOcean Development Kit).
3. As long as transmitter IDs are stored in ID memory, the operating mode can't be changed.
4. All known considerations regarding correct (HF) layout, antenna design, and proper low noise power supply remain valid.

#### Disclaimer

The information provided in this document describes typical features of the EnOcean radio system and should not be misunderstood as specified operating characteristics. No liability is assumed for errors and / or omissions. We reserve the right to make changes without prior notice. For the latest documentation visit the EnOcean website at [www.enocean.com](http://www.enocean.com).