

CASE STUDY

TEC Building Systems uses SmartServer™ IoT to Upgrade Legacy Infrastructure

LON controllers in a New York City airport terminal now communicate natively to BACnet BMS



Exec Summary

TEC Building Systems, LLC, one of the largest New York City master systems integrators, was challenged by the owners of a local airport terminal to extend the life of the building's VAV control system – a key part of the HVAC infrastructure. The VAV system's supervisory controllers were slowly failing and were no longer supported by the manufacturer, and a protocol mismatch between the building's many LON-based field-level VAV controllers and the BACnet-based BMS made communication impossible. Ripping out and replacing the entire VAV system was cost prohibitive and unnecessary since it was a functioning system, so TEC needed a solution that could provide a critical bridge between the many field-level LON-based controllers and the BACnet infrastructure. They chose EnOcean's SmartServer IoT because of its ability to completely map LON and many other field bus protocols with BACnet based supervisory systems and BMS. With SmartServer IoT, TEC was able to extend the life of the terminal's legacy infrastructure in an easy and affordable way.

The Challenge

TEC Building Systems, LLC is a New York City systems integrator that custom designs state-of-the-art control solutions for the most challenging building automation needs. TEC was tasked by the owners of a local airport terminal to extend the life of the building's Variable Air Volume (VAV) control system – a key part of the building's HVAC infrastructure.

CASE STUDY

Like tens of thousands of buildings around the world that were built in the 1980s and 1990s, the terminal's infrastructure was built on Honeywell Excel controllers communicating via the LON protocol. The setup of the terminal's VAV control system was quite straightforward: it used a combination of 84 Honeywell Excel 10 VAV II controllers, communicating via a LON router to an Excel 10 Zone Manager which then communicated to the building management system (See Fig. 1).

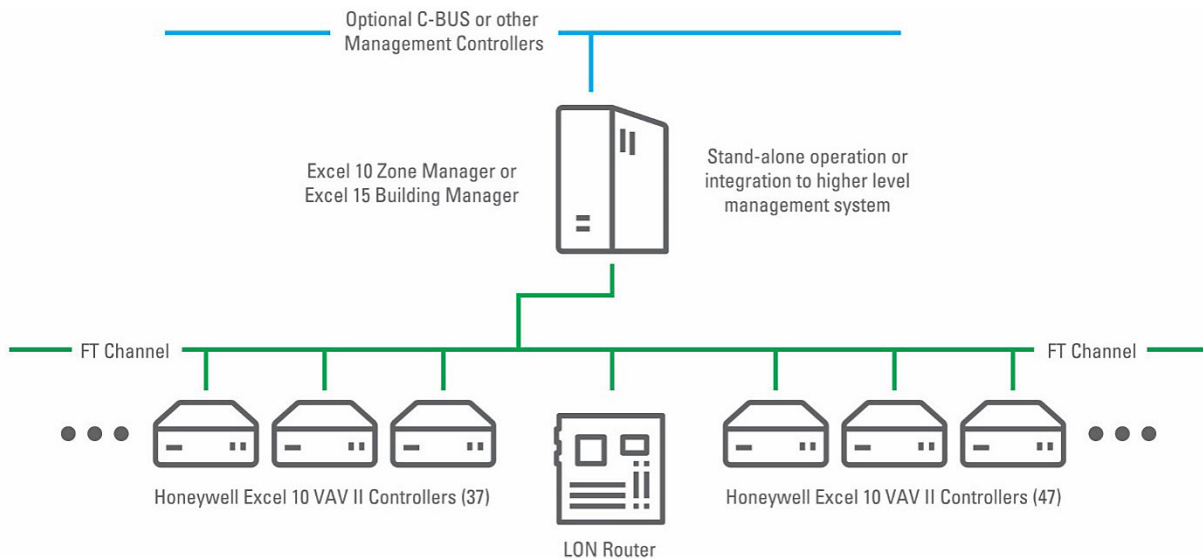

Fig. 1: Airport terminal VAV control infrastructure

Unfortunately, after many years of use, the zone manager/supervisory controller failed, as did the router/repeater. All of these parts had been discontinued and were no longer supported or available in the market. While the many VAV controllers scattered throughout the building were functioning just fine, without the supervisory controllers, the control system was unable to function.

The building managers could either rip out and replace all the VAV controllers or reintegrate the controllers behind a new type of supervisory solution. Replacing the VAV controllers didn't make sense since they were all in fine working condition.

The complicating factor with reintegrating the controllers through another routing solution was a protocol mismatch: communication southbound to the VAV controllers was via LON and communication northbound to the BMS was via BACnet IP. TEC needed a solution that could provide an effective bridge between these systems.

The Solution

TEC decided to use EnOcean's SmartServer IoT edge server to provide this bridge, using it to replace the supervisory controller and the router/repeater. SmartServer IoT is an open, industrial-rated platform with built-in drivers and interfaces to numerous IoT and building automation protocols. It supports engineering, provisioning, monitoring, and life-cycle management of devices within a building automation and control systems (BACS) architecture, and uniquely enables these devices to be integrated with each other across protocols.

At the heart of the SmartServer IoT is the IoT Access Protocol (now ANSI/CTA standard 709.10) that provides a common information model and services that run across commercial IoT, industrial IoT, IT, and web infrastructure. Its unifying information model enables devices, services and platforms to understand and interpret the meaning of and relationships between data types.

CASE STUDY

SmartServer IoT was used to create digital twins of the LON-based VAV II controller datapoints and present them in a native format to the BACnet-based Honeywell EBI (Enterprise Building Integrator) server. In this way, SmartServer IoT was able to provide a seamless bridge between the LON controllers and the BACnet management system, as shown in Fig. 2.

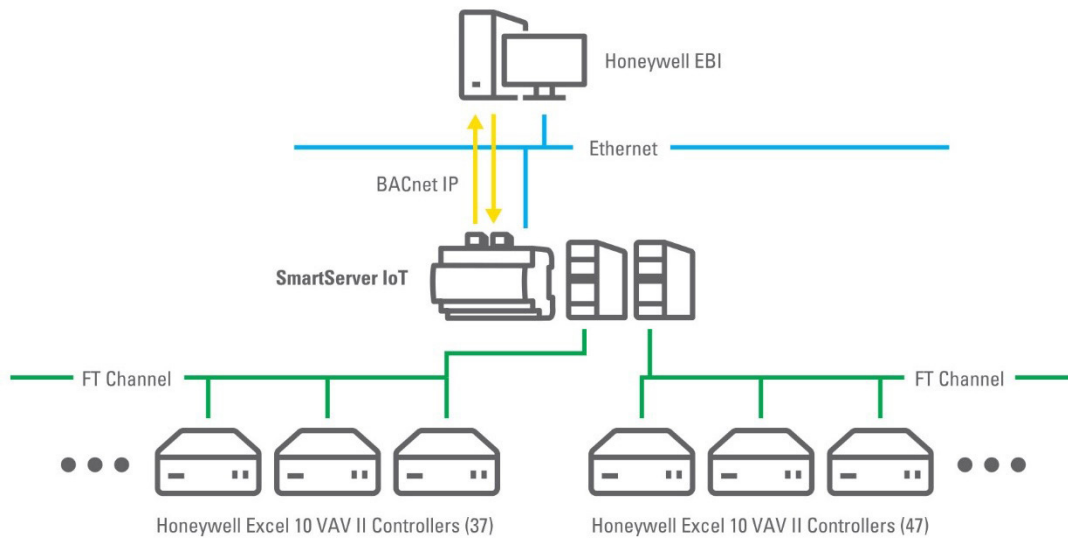

Fig. 2: SmartServer IoT exposes LON datapoints as BACnet datapoints to the EBI server

The Result

By replacing the supervisory controller and the router/repeater with a SmartServer IoT, TEC was able to reinvigorate the control system at the airport terminal to ensure it would be in working order for the foreseeable life of the terminal. Today, the system is running smoothly, and because it is not a full-fledged operating system, SmartServer IoT doesn't need ongoing maintenance. The cost savings were significant: by avoiding the need to rip out and replace the entire VAV system, the terminal owners were able to save hundreds of thousands of dollars. Importantly, they were also able to do this with minimum disruption – a huge consideration for an occupied airport terminal supporting hundreds of flights per day.

Looking Ahead

In this particular deployment, the project was focused on the VAV control system, but this is just one example of a widespread issue. There are numerous other legacy systems that will face – or are already facing – the challenge of failing and obsolete equipment.

For more than 20 years, Excel 10 and Excel 15 controllers were used across office buildings, schools, and high-rises in New York City, and in tens of thousands of buildings around the world. In some instances, there are thousands of Excel 10 and Excel 15 controllers spread throughout a building, handling everything from VAV systems to chilled ceiling controllers, fan coil units, hydronic controllers, thermostats, AHU controllers, ventilator controllers and more. As the supervisory controllers begin to fail, building owners need manageable, cost-sensitive solutions.

While not all of these systems will require an upgrade to BACnet, and some systems may not fail at all, for the ones that do, the most sensible solution won't be to rip them out and replace them. It's just too difficult and expensive, especially for a building that may only have 10 or 20 more years of useful life.

For these deployments, SmartServer IoT can provide an easy, affordable and low-maintenance bridge between legacy systems and newer technologies. In addition to mapping any IoT data to BACnet IP, SmartServer IoT can make control and automation data available to modern software analytics and management systems via its bidirectional MQTT and RESTful APIs for web services. In this way, analytics and AI can work alongside traditional BMS architectures.

In addition, the work done on this deployment is easily replicated to other deployments. Unique features in the SmartServer IoT make this a painless process. All that's needed is to clone and replicate the reference build, then provision the specific devices at each site.

CASE STUDY

Learn More



Learn more about the [SmartServer IoT](#).



View a webinar on [The Case for an Open IoT 'Data Fabric' for Smart Buildings Integration](#).



Access pre-built package files for Excel 10 controllers to be used with SmartServer IoT on [Github](#).



[Contact us for a demo](#).

LoRaWAN® is a mark used under license from the LoRa Alliance.

EnOcean

EnOcean GmbH
Kolpingring 18a
82041 Oberhaching
Germany

Contact Information

For further information about our products or technology
please visit www.enocean.com or contact us
at info@enocean.com.