

Using TCM 310 transceivers in bidirectional low power applications

1. ABSTRACT

EnOcean TCM 310 device default firmware is called "GatewayController" and it uses the ESP3 communication protocol.

Typical applications are line powered, working as receiver/transceiver which "never sleeps" therefore consuming > 33 mA@3 V (receiver on) continuously.

One of TCM 310 less known, because actually typical unused features for a transceiver is that it has a watchdog and it can be put in "deep sleep" (energy saving mode) through correspondingly ESP3 serial common command "CO_WR_SLEEP" (for x milliseconds time period) as shown below:

1.10.3 Code 01: CO_WR_SLEEP

Function: Order to enter the energy saving mode.

Group	Offset	Size	Field	Value hex	Description
-	0	1	Sync. Byte	0x55	
Header	1	2	Data Length	0x0005	5 bytes
	3	1	Optional Length	0x00	0 byte
	4	1	Packet Type	0x05	COMMON_COMMAND = 5
-	5	1	CRC8H	0xnn	
Data	6	1	COMMAND Code	0x01	CO_WR_SLEEP = 1
	7	4	Deep sleep period	0x00nnnnnn	Period in 10 ms units 00000000 = default max. value = max. data range 00 FF FF FF (~ 46h); After waking up, the module generate an internal hardware reset
-	11	1	CRC8D	0xnn	

Table 21

In this case, the following **RESPONSE** message gives only the return codes:

00 RET_OK

The device deep sleep current drops then below 0.3 μ A (meaning factor about > 100k less vs. "normal mode").

An issue is that in deep sleep the device can't neither receive nor transmit any messages, neither over its radio nor over its serial interface. The only possibility to wake-up from deep sleep remains its watchdog or a SOR (= Supply-On Reset).

The proposed circuit shows just one implementation example of this feature on a TCM 310 device used as transceiver in some specific bidirectional low power applications.

An energy balance respectively specific use case trade-off should be made however before between two approaches:

- switching TCM supply voltage off between two communication cycles (no deep sleep current at all but relatively long, up to 500 milliseconds according user manual) "cold" start-up time by (same) high current, vs.:
- keeping it instead in deep sleep mode by significantly faster start-up (few milliseconds), depending on the required communication frequency.

Using TCM 310 transceivers in bidirectional low power applications

In some low power applications like i.e. wireless heating valve actuators the device could be operated most of the time in deep sleep waking up only cyclical and for very short time frames to communicate with the system (i.e. an ultralow power controller). In this way high amounts of energy can be saved, enabling the device to work powered i.e. by battery or even energy harvester.

The example below shows how to cut the UART lines of the EnOcean Dolphin based device during deep sleep in low power applications in order to avoid reverse residual currents and minimize accordingly the system current consumption. Typical use cases are applications where a third part ultralow power microcontroller used as "master" cyclical communicates through UART with TCM 310. The ultralow power master drives i.e. a heating valve (actuator) and is usually always "on". It communicates serial over very short time frames through the UART (ESP3 protocol) with the TCM device (slave). The device has an internal watchdog and sleeps most time. The master is waiting then on TCM 310 wakeup (readiness), confirmed by the ESP3 "CO_READY" message, communicates with (for milliseconds) and finally sends a new ESP3 "CO_WR_SLEEP" (for a determined time, see above) command on UART to the device. This automatically confirms the received ESP3 command (RET_OK) and goes sleep for the given time, wakes up then again and a new communication cycle starts.

In the proposed circuit T1 and Q1 are driven by DVDD to switch IOVDD (supply voltage for all I/O's) to VDD on during the communication and off thereafter. The UART "cutting" circuit is identical for both I/O lines and consists of N-channel enhancement MOSFET's (Q2, Q3) driven by the DVDD/IOVDD.

Both MOSFET gates have to be connected direct to IOVDD, their sources to the correspondingly I/O lines on the slave (A) section side while their drains (D) to the same I/O lines on the master (B) section side (always powered, common supply voltage VDD).

Note: most MOSFET have the substrate internally already connected to the source; otherwise this should be done externally. The associate diodes between drain (D) and substrate (source, S) present as intrinsic n-p junction of drain and substrate inside these MOSFET's play a key role in this circuit as shown below.

For the operation four states has to be considered:

1. Device A (TCM, slave) sleeps, DVDD is 0 V, T1 & Q1 are blocked and the IOVDD path is consequently not supplied by +3.3 V (VDD). Accordingly the I/O of the slave section is in "three-state". The gate and the source of the MOSFET are both "three-state", so their V_{GS} are below the threshold voltage and both MOSFET are not conducting. This allows that the UART lines at the master section are i.e. pulled up by their own pull-up (internal) resistors to +3.3 V. The consequently invers biased (integrated) MOSFET diodes are blocking however both I/O lines which are consequently physically "interrupted" between TCM (A, slave) and B (master).

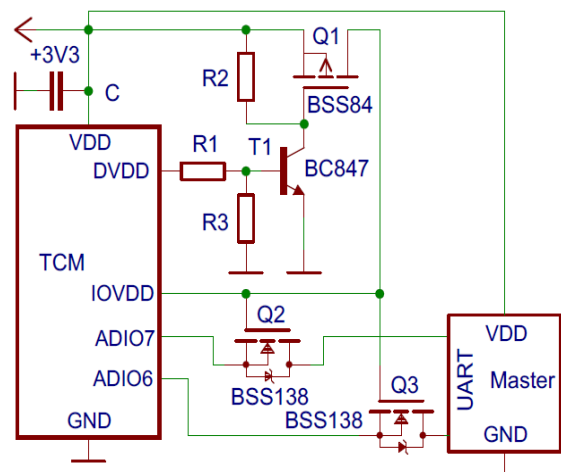

Using TCM 310 transceivers in bidirectional low power applications

2. Device A (slave) wakes up (internal watchdog), IOVDD is switched through T1 & Q1 on (to VDD = +3.3 V), consequently its I/O lines are internally pulled up (default). As long as no device actively communicates (pulling down the correspondingly I/O side) they remain HIGH: the gate and the source of the MOSFET are both at +3.3 V (device A), so the VGS is below the threshold voltage and the MOSFET's are not conducting (internal diodes also not because having on both side HIGH level). This allows that the correspondingly I/O lines on the master section (B) side are pulled up by its own (internal) pull-up resistors to the same +3.3 V. The I/O lines of both sections stay HIGH.
3. Now device A (slave) sends i.e. a message to the device B (master) through I/O, means temporary pulls i.e. down the correspondingly I/O line to LOW. The source of the correspondingly MOSFET becomes also LOW, while the gate stay at +3.3 V (IOVDD). The VGS rises above the threshold and the MOSFET becomes conducting. Now the same line on the master section side is also (temporary) pulled down to LOW by the device A via the conducting MOSFET. The correspondingly I/O line on both sections becomes LOW.
4. Same situation but now device B (master) pulls (temporary) down the correspondingly I/O line to LOW (by sending i.e. a "go sleep" message to the slave). Via the now direct biased drain-substrate diode of the MOSFET the slave section is in first instance pulled (temporary) down until VGS passes the threshold and the MOSFET becomes conducting. Now the I/O line of the slave section is further pulled down to LOW by the B device via the conducting MOSFET. The correspondingly I/O line on both sections becomes LOW.

Conclusion: the above described states show that the logic levels are correctly transferred in both directions of the UART, independent who is the driving section (A or B). It also shows that during sleep the UART lines between slave and master are cut so no residual currents flow from VDD over the TCM I/O's in this time. The circuit complies with the Dolphin Core requirements regarding GPIO supply voltage in deep sleep mode and minimizes accordingly the current consumption of the system.

Note: for correct operation the supply voltage VDD (and IOVDD) should be common (i.e. +3.3 V) for both devices, master and slave. With a V_{GS} threshold voltage of about 1 V below the lowest VDD the circuit will operate properly. If for example the lowest VDD is +3 V, a threshold voltage V_{GS} of maximum 2 V is therefore allowed. Discrete BSS138 (N-channel Enhancement Mode) respectively BSS84 (P-channel Enhancement Mode) small signal SMD MOSFET's, both with low V_{GS} are a good choice therefore. R1, R2 and R3 can be very large, typically merely $M\Omega$, up to tens of $M\Omega$.

The screen shot picture shows the above described behavior. Signals color: green DVDD, pink IOVDD, yellow and blue the two UART lines (I/O's).

From left to right: both device are initially awaken, TCM device receives (on ADIO6, yellow) the command "Go sleep" from the master. It confirms immediately the received command (ADIO7, blue) to master and then it goes sleep (DVDD, green fails to Low), followed with some delay by IOVDD (pink) and UART (yellow & blue). While the master (B) is still on, the TCM UART paths (ADIO6 and ADIO7) are "open" during TCM sleep time (right in picture).

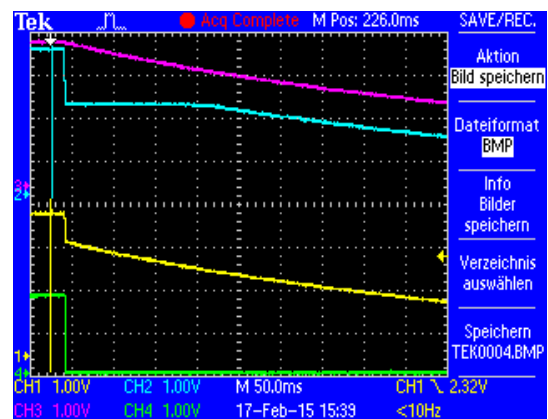

Using TCM 310 transceivers in bidirectional low power applications

Remark: Current TCM 310 FW are meantime optimized with regard to energy consumption; other as by formerly TCM 310 FW versions, starting with version "GATEWAYCTRL 2.11.0.8" (TCM 310 FW release -14 and higher), the receiver (highest current consumption) will be switched off immediately after receiving the command "CO_WR_SLEEP", enabling additional energy savings.

Further Documentation:

https://www.enocean.com/de/enocean_module/tcm-310/

<https://www.enocean.com/esp>

<https://www.enocean.com/dolphin-core-description/>

https://www.enocean.com/fileadmin/redaktion/pdf/app_notes/AN101_POWER_SUPPLY_LAYOUT_2015.pdf

Disclaimer

The information provided in this document is subject to modifications and intended for reference purposes only.

EnOcean assumes no liability either for violation of industrial property or other rights of third parties that stem from this information, nor for errors and / or omissions.

We reserve the right to make changes without prior notice. Make sure that this is the latest version of the document before use. For the latest documentation, visit the EnOcean website at www.enocean.com