

STM 350 / STM 350U (STEPCODE DE OR HIGER)  
TEMPERATURE AND HUMIDITY SENSOR MODULE

---



Observe precautions! Electrostatic sensitive devices!

Patent protected:

WO98/36395, DE 100 25 561, DE 101 50 128,  
WO 2004/051591, DE 103 01 678 A1, DE 10309334,  
WO 04/109236, WO 05/096482, WO 02/095707,  
US 6,747,573, US 7,019,241

## STM 350 / STM 350U (STEP CODE DE OR HIGER) TEMPERATURE AND HUMIDITY SENSOR MODULE

### REVISION HISTORY

The following major modifications and improvements have been made to this document:

Version	Author	Reviewer	Date	Major Changes
1.0	MKA	MKA	10.01.2018	First release
1.1	MKA	MKA	15.06.2018	Update of FCC certification
1.2	MK	MK	31.05.2019	Update with long term energy storage replacement, additional transport mode for shelf storage & air cargo, optimized secure mode, additional information on market approval for secondary battery, new drawings, new QR code and logo update
1.3	MK	MK	24.10.2019	Added comment about SIG telegram and energy status, typo 2.2. footnote
1.4	MK	CB	29.11.2019	Added connection of external backup battery

**Published by EnOcean GmbH, Kolpingring 18a, 82041 Oberhaching, Germany  
www.enocean.com, info@enocean.com, phone +49 (89) 6734 6890**

© EnOcean GmbH, All Rights Reserved

Other trademarks and trade names are those of their respective owners.

#### **Important!**

This information describes the type of component and shall not be considered as assured characteristics. No responsibility is assumed for possible omissions or inaccuracies. Circuitry and specifications are subject to change without notice. For the latest product specifications, refer to the EnOcean website: <http://www.enocean.com>.

As far as patents or other rights of third parties are concerned, liability is only assumed for modules, not for the described applications, processes and circuits.

EnOcean does not assume responsibility for use of modules described and limits its liability to the replacement of modules determined to be defective due to workmanship. Devices or systems containing RF components must meet the essential requirements of the local legal authorities.

The modules must not be used in any relation with equipment that supports, directly or indirectly, human health or life or with applications that can result in danger for people, animals or real value.

Components of the modules are considered and should be disposed of as hazardous waste. Local government regulations are to be observed. Packing: Please use the recycling operators known to you.

STM 350 / STM 350U (STEPCODE DE OR HIGER)  
TEMPERATURE AND HUMIDITY SENSOR MODULE

---

**TABLE OF CONTENT**

- 2 GENERAL DESCRIPTION ..... 4
  - 2.1 Basic functionality ..... 4
  - 2.2 Technical Data ..... 5
  - 2.3 Ordering Information ..... 6
  - 2.4 Physical dimensions ..... 6
    - 2.4.1 Mechanical Outline ..... 6
- 3 FUNCTIONAL DESCRIPTION ..... 7
  - 1.1 Commissioning and mode change ..... 7
  - 3.1 Simplified device block diagram ..... 8
  - 3.2 Measurement and transmission timing ..... 8
  - 3.3 Radio telegram format and interpretation ..... 9
  - 3.4 High security communication ..... 9
- 4 Application Information ..... 11
  - 4.1 Transmission range ..... 11
  - 4.2 Connecting an external backup battery ..... 11
- 5 Regulatory information ..... 12
  - 5.1 Radio Equipment Directive (RED) for the European Union ..... 12
  - 5.2 FCC (United States) certification ..... 13
  - 5.3 Label information ..... 14
  - 5.4 QR Code ..... 14

## STM 350 / STM 350U (STEPCODE DE OR HIGER) TEMPERATURE AND HUMIDITY SENSOR MODULE

## 2 GENERAL DESCRIPTION

**This user manual specifies STM 350 modules with stepcode DE or later:**

- See chapter "6.1 Product Label" to find out the module stepcode
- User manual for older modules can be downloaded from the product website
- For a detailed description of product changes see Product Change Notification (PCN).

### 2.1 Basic functionality

The extremely power saving RF transmitter modules STM 350 and STM 350U of EnOcean is optimized for realization of wireless and maintenance free temperature and humidity sensors.

They require no external components and provides on-board a calibrated temperature and humidity sensor.

STM 350 and STM 350U wake up at a rate of approximately once every 100 seconds to read the status of the integrated temperature and humidity sensor.

If there is a significant change in measured temperature (more than 0.5 K) or humidity (more than 3% r.h.) versus the last reported values then a radio telegram will be transmitted immediately. In case of no relevant input change, a redundant retransmission signal (heartbeat) is sent after 15 minutes to announce the current values.

Power is provided to STM 350 and STM 350U by means of a small pre-installed solar cell which works in conjunction with an integrated energy storage element in order to ensure operation in periods without ambient light. The available energy within the energy storage element is continuously monitored and reported regularly.

STM 350 and STM 350U additionally provide the option to connect an external 3 V backup battery to enable operation with little or no available light.

### Key product features

- Fully autonomous operation under sufficient lighting with pre-installed solar cell
- On-board energy storage and charging circuit with energy level reporting
- On-board LRN button
- On-board TX indicator LED
- Factory calibrated on-board temperature and humidity sensor
- Support for high security communication (encrypted and authenticated)

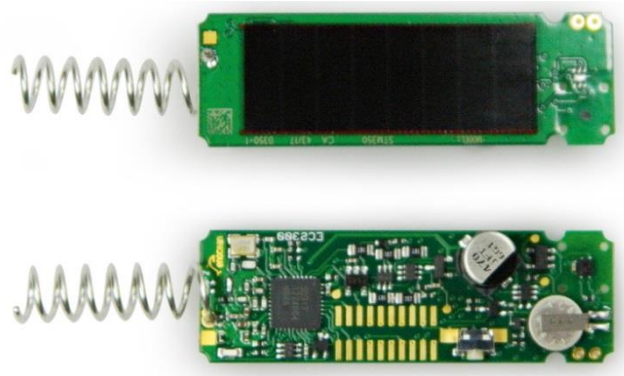

## STM 350 / STM 350U (STEP CODE DE OR HIGER) TEMPERATURE AND HUMIDITY SENSOR MODULE

### 2.2 Technical Data

<b>Antenna</b>	Helix antenna
<b>Frequency / Modulation</b>	STM 350: 868.3 MHz / ASK (EnOcean Radio Protocol) STM 350U: 902.875 MHz / FSK (EnOcean Radio Protocol)
<b>Data rate</b>	125 kbps
<b>Radiated Output Power (typ.)</b>	STM 350: +5 dBm (EIRP) STM 350U: +99 dB $\mu$ V/m
<b>On-board Power Supply</b>	Pre-installed solar cell Illumination 100-10000 lux
<b>Auxiliary Power Supply</b>	Option for backup battery (3V)
<b>Operation time in darkness @ 25°C</b>	min. 10 days, if energy storage fully charged <sup>1)</sup>
<b>Start-up time from empty energy store</b>	typ. < 5 min @ 400 lux / 25 °C incandescent or fluorescent light
<b>Input parameters</b>	Temperature and humidity sensor LRN button
<b>Temperature sensor performance</b>	Measurement range: -20°C ... +60 °C (0.1K resolution) Accuracy: $\pm$ 0.5 K across entire range
<b>Humidity sensor performance</b>	Measurement range: 0 % ... 100 % r.h. (0.4% resolution) Accuracy: $\pm$ 4.5 % r.h. across entire range $\pm$ 3.0 % r.h. between 20 ... 80 % r.h.
<b>Measurement interval</b>	Approximately once every 100 s
<b>Transmission interval</b>	Every 7 ... 14 measurements (affected at random) Immediate transmission in case of significant change
<b>Threshold for immediate transmission</b>	Temperature: >0.5 K difference versus last reported value Humidity: > 2 % r.h. difference versus last reported value
<b>EnOcean Equipment Profile (EEP)</b>	A5-04-03 SIGNAL 0x06 (Energy Level Reporting) SIGNAL 0x0E (Entering Transport Mode)
<b>Radio regulations</b>	RED (EU): STM 350 FCC (US) / ISED (CA): STM 350U
<b>Operating and Storage temperature</b>	Absolute Maximum: -20 °C ... +60 °C Recommended <sup>1)</sup> : +10 °C...+30 °C
<b>Shelf life (in absolute darkness)</b>	36 months after delivery <sup>2)</sup>
<b>Operating and storage humidity</b>	Maximum: 0% ... 93% r.h., non-condensing Recommended: < 60% r.h.



The module shall not be placed on conductive materials, to prevent discharge of the internal energy storages. Even materials such as conductive foam (ESD protection) may have negative impact.

<sup>1)</sup> Energy storage performance degrades over life time, especially if energy storage is long time exposed to very high temperatures. High temperatures will accelerate aging. Very low temperature will temporary reduce capacity of energy store and this leads to considerable shorter dark time operation.

<sup>2)</sup> Deep discharge of the energy storage leads to degradation of performance. Therefore products have to be taken into operation after 36 months.

STM 350 / STM 350U (STEPCODE DE OR HIGER)  
TEMPERATURE AND HUMIDITY SENSOR MODULE

2.3 Ordering Information

Type	Ordering Code	Frequency	Note
STM 350	S3001-D350	868.3 MHz	Helix antenna, side-facing button and LED
STM 350U	S3051-D350	902.875 MHz	Helix antenna, side-facing button and LED

2.4 Physical dimensions

PCB dimensions	50±0.2 x 16±0.3 x 1±0.1 mm
Module height	10 mm
Weight	5 g

2.4.1 Mechanical Outline

Detailed drawings and a 3D model are available from EnOcean.

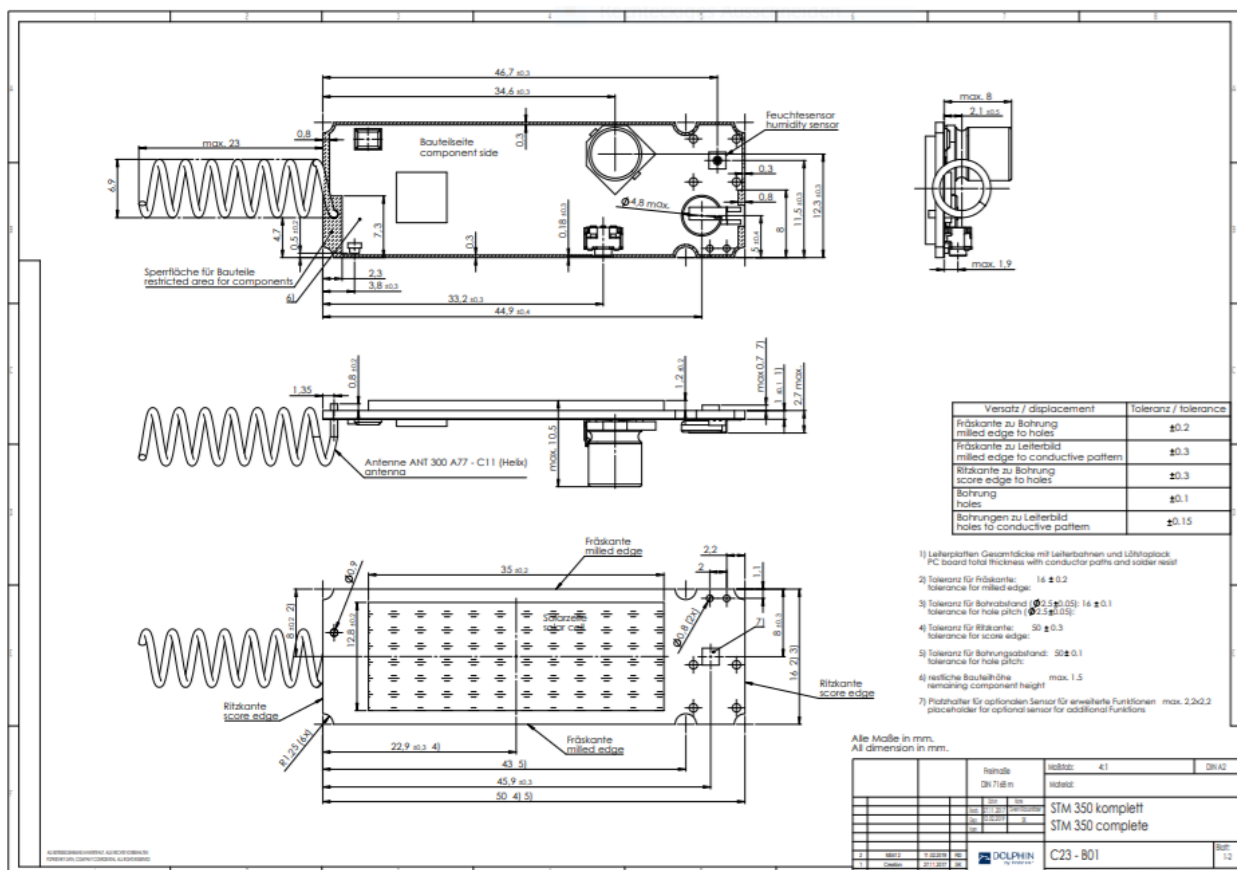

STM 350 / STM 350U (STEPCODE DE OR HIGER)  
TEMPERATURE AND HUMIDITY SENSOR MODULE

### 3 FUNCTIONAL DESCRIPTION

#### 1.1 Commissioning and mode change

The module will be shipped in transport mode to switch off the energy store for long term shelf storage and air cargo. The mode can be changed by pressing the learn button. The procedure for enter the standard mode has not been changed to keep compatible with modules before stepcode DE.

Make sure that the solar cell will get enough light for mode change and/or learn telegram.

- **Change from transport to standard mode**

After pressing the learn button 1x short (1s) the radio module will enter Standard Mode (Mode 1). The LED will flash 1x and a standard learn telegram will be sent.

- **Change from standard to secure mode**

After pressing the learn button 2x long (2x 5s, pause <1s) the radio module will enter Secure Mode (Mode 2). A secure learn telegram will be sent and the LED will flash 2x.

- **Change from secure or standard mode to transport mode**

After pressing the learn button 1x long (5s) the radio module will enter Transport Mode (Mode 3). A signal telegram (0x0E) will be sent and the LED will flash 3x.

The following diagram illustrates all implemented mode transitions.

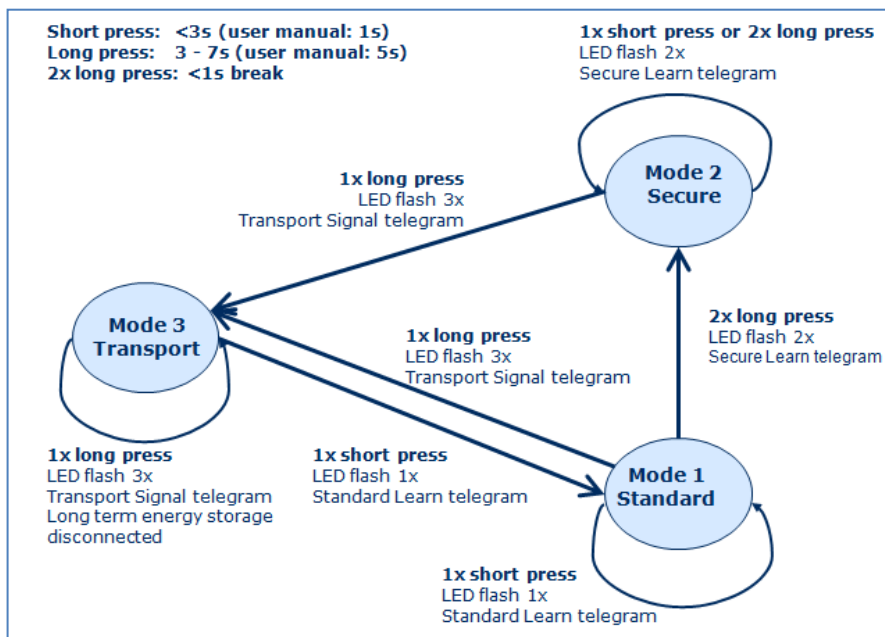

Short press: **1 s** (firmware 0.1 – 3.0 s)

Long press: **5 s** (firmware 3 – 7 s)

2x long press with very short pause of max. 1 s between

## STM 350 / STM 350U (STEP CODE DE OR HIGER) TEMPERATURE AND HUMIDITY SENSOR MODULE

### 3.1 Simplified device block diagram

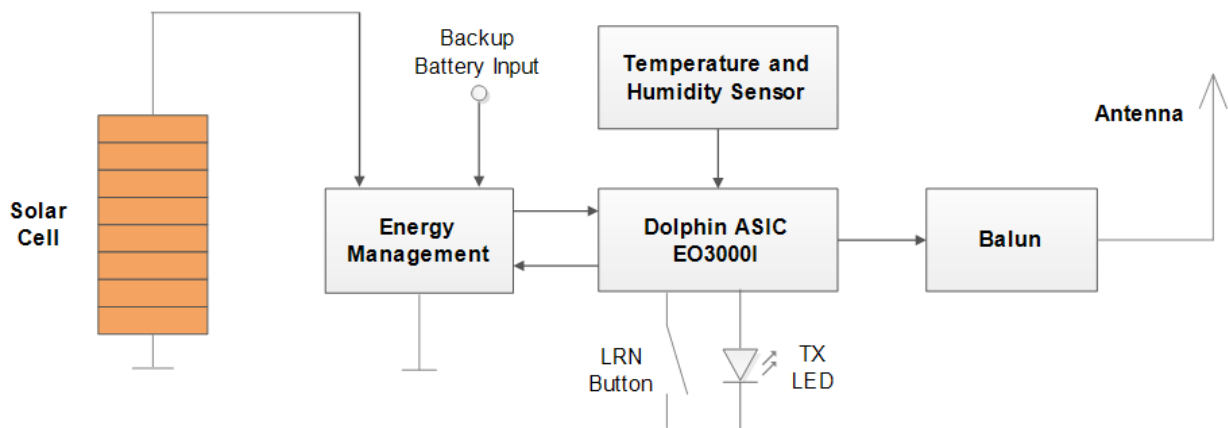

### 3.2 Measurement and transmission timing

STM 350 and STM 350U wake up approximately once every 100 seconds to measure temperature and humidity. The measured values are then compared against the last reported (transmitted) values. If there is a significant change then the measured values are transmitted immediately.

Significant change is defined as follows:

- Temperature  
The measured temperature deviates from the last reported temperature by more than 0.5 K
- Humidity  
The measured humidity deviates from the last reported humidity by more than 2% r.h.

In absence of a significant change, a heartbeat telegram reporting the currently measured values are transmitted for every 7 ... 14 measurements (affected at random). The setup of the transmission timing allows avoiding possible collisions with data packages of other EnOcean transmitters as well as disturbances from the environment.

In addition, STM 350 and STM 350U reports the estimated energy level on their internal energy storage element approximately every 100 measurements.

With each default transmission cycle, 3 identical sub-telegrams (secure mode 2) are transmitted within 40ms. Transmission of a sub-telegram lasts approximately 1.2ms. The delay between the three transmission bursts is affected at random.



## STM 350 / STM 350U (STEPCODE DE OR HIGER) TEMPERATURE AND HUMIDITY SENSOR MODULE

---

### 3.3 Radio telegram format and interpretation

STM 350 and STM 350U transmit telegram data according to EEP (EnOcean Equipment Profile) A5-04-03 which encodes a temperature range of Temperature -20 ... 60°C with 10 Bit and a humidity range of 0 ... 100 % r.h. with 8 Bit.

In addition, STM350 and STM 350U report their internal energy level using a SIGNAL telegram of type 0x06. The energy status of the module is reported in a range from 0 - 100 %. The reported value is estimated from the supply voltage level of the energy storage. Charging situation, life time and high or low operating temperature can lead to fluctuations and deviations of the reported energy level.

Mode change to transport mode is reported by a SIGNAL telegram of type 0x0E.

For details see: <https://www.enocean-alliance.org/what-is-enocean/specifications/>

### 3.4 High security communication

STM 350 and STM 350U support high security communication where the telegram payload is both encrypted and authenticated.

High security communication can be used to address two main issues:

- Unauthorized interception (reception and correct interpretation) of transmitted data  
In doing so, a third (unauthorized) party is able to understand the content of a received content.
- Unauthorized transmission of radio telegrams  
In doing so, a third (unauthorized) party is able to transmit a radio telegram that is treated by a receiver as valid request.

Somewhat loosely speaking, the goal of security has to be preventing an unauthorized person (often referred to as an *Attacker*) both from learning about the current state of a system and from actively changing it.

These goals can be achieved via techniques such as telegram encryption, telegram authorization and dynamic security key modification. All three techniques are supported by STM 350 and STM 350U.

## STM 350 / STM 350U (STEPCODE DE OR HIGER) TEMPERATURE AND HUMIDITY SENSOR MODULE

---

### 3.4.1 High security communication parameters

STM 350 and STM 350U support high security communication with the following parameters:

- Encryption algorithm: Variable AES 128 (VAES)
- Key length: 128 bit
- Key modifier: 24 bit rolling code
- Signature: 24 bit CMAC

For details about the security in EnOcean networks, please check the "Security of EnOcean Radio Networks" specification.

### 3.5 Teach-in telegram

If the user presses the LRN button then the module transmits a teach-in telegram according to the current communication mode (4BS teach-in telegram for standard mode, secure teach-in telegram for high security mode).

With this special teach-in telegram it is possible to identify the manufacturer of a device and the function and type of a device via the EEP that is used.

## STM 350 / STM 350U (STEPCODE DE OR HIGER) TEMPERATURE AND HUMIDITY SENSOR MODULE

---

### 4 Application Information

#### 4.1 Transmission range

The main factors that influence the system transmission range are type and location of the antennas of the receiver and the transmitter, type of terrain and degree of obstruction of the link path, sources of interference affecting the receiver, and “Dead” spots caused by signal reflections from nearby conductive objects. Since the expected transmission range strongly depends on this system conditions, range tests should categorically be performed before notification of a particular range that will be attainable by a certain application.

The following figures for expected transmission range may be used as a rough guide only:

- Line-of-sight connections: Typically 30 m range in corridors, up to 100 m in halls
- Plasterboard walls / dry wood: Typically 30 m range, through max. 5 walls
- Ferroconcrete walls / ceilings: Typically 10 m range, through max. 1 ceiling
- Fire-safety walls, elevator shafts, staircases and supply areas should be considered as screening.

The angle at which the transmitted signal hits the wall is very important. The effective wall thickness – and with it the signal attenuation – varies according to this angle. Signals should be transmitted as directly as possible through the wall. Wall niches should be avoided. Other factors restricting transmission range:

- Switch mounted on metal surfaces (up to 30% loss of transmission range)
- Hollow lightweight walls filled with insulating wool on metal foil
- False ceilings with panels of metal or carbon fiber
- Lead glass or glass with metal coating, steel furniture

The distance between EnOcean receivers and other transmitting devices such as computers, audio and video equipment that also emit high-frequency signals should be at least 0.5 m. A summarized application note to determine the transmission range within buildings is available as download from [www.enocean.com](http://www.enocean.com).

#### 4.2 Connecting an external backup battery

In case of insufficient light for operation with solar cell an external 3 V Lithium backup battery can be connected to the module at the soldering pads shown below. The operation time with CR1225 backup battery will be typ. 5 years in total darkness.

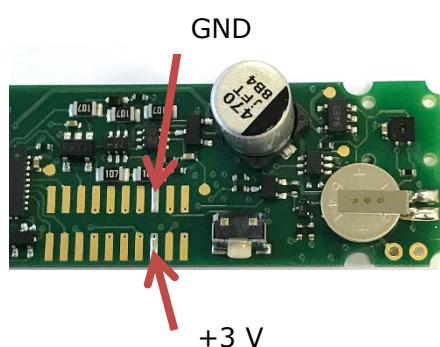

## STM 350 / STM 350U (STEPCODE DE OR HIGER) TEMPERATURE AND HUMIDITY SENSOR MODULE

---

### 5 Regulatory information

STM 350 has been tested to fulfil the approval requirements for RED. STM 350U has been tested to fulfil the approval requirements for FCC and ISSED.

Test reports are only valid for the delivered modules with their standard (unmodified) hardware and software. STM 350 and STM 350U HW and SW design must not be modified and they must not be used outside their specification limits.

#### 5.1 Radio Equipment Directive (RED) for the European Union

The Radio Equipment Directive (2014/53/EU, typically referred to as RED) replaces the old R&TTE directive from 1999 as regulatory framework for radio products in the European Union. All products sold to final customers after 12th of June, 2017 have to be compliant to RED. At the time of writing, the text of the RED legislation was available from this link: <http://eur-lex.europa.eu/eli/dir/2014/53/oj>

Dolphin radio modules such as STM 350 are components which are delivered to OEM manufacturers for their use in final or combined products. The final product incorporating EnOcean RF modules must itself meet the essential requirement of the EU directives and a CE marking must be affixed on the final product and on the sales packaging each. Operating instructions containing a Declaration of Conformity have to be attached.

It is the responsibility of the OEM manufacturer to demonstrate compliance to all applicable EU directives and standards. The attestation of conformity for STM 350 serves as input to the declaration of conformity for the full product.

At the time of writing, guidance on the implementation of EU product rules – the so called “Blue Guide” – was available from this link: <http://ec.europa.eu/DocsRoom/documents/18027/>

Specifically within the new RED framework, all OEM manufacturers have for instance to fulfill the following additional requirements:

- Provide product branding clearly identifying company name or brand and product name as well as type, charge or serial number for market surveillance
- Include documentation containing full postal address of the manufacturer as well as radio frequency band and max. transmitting power
- Include user manual, safety information and a declaration of conformity for the final product in local language
- Provide product development and test documentation upon request

Please contact an accredited test house for detailed guidance.

## STM 350 / STM 350U (STEP CODE DE OR HIGER) TEMPERATURE AND HUMIDITY SENSOR MODULE

---

### **5.2 FCC (United States) certification**

STM 350U has been approved by FCC and IC for use within the ETHSU end product.

Modular approval of STM 350U is not possible according to the current radio certification guidelines due to the absence of a radio shield. Use of STM 350U in customer products therefore requires a product-specific approval. The technical parameters of STM 350U allow such approval.

Please contact EnOcean Application Engineering North America ([support.na@enocean.com](mailto:support.na@enocean.com)) for additional details.

STM 350 / STM 350U (STEPCODE DE OR HIGER)  
TEMPERATURE AND HUMIDITY SENSOR MODULE

**5.3 Label information**

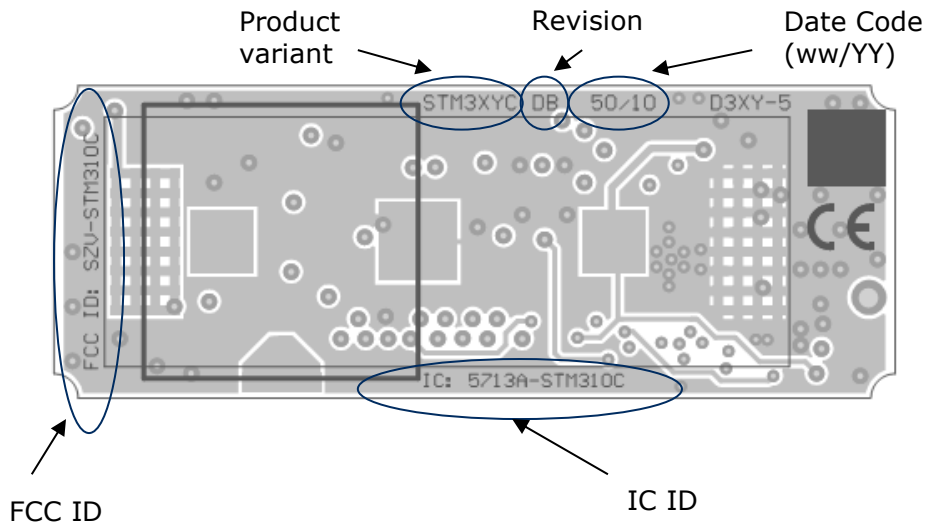

**5.4 QR Code**

In order to improve STM 350x logistic and commissioning a QR code label is fixed on top of the radio controller. The QR code is implemented according to the EnOcean Alliance system specification: "Product ID and Standardized Labeling Specification". For details see: <https://www.enocean-alliance.org/productid/>



Example image STM 420J

**Format (STM 350):**

[30S00000502CB78+13ZBA2054A875E77768C7740157BDF9CF68+30PS3001-D330+2PDE15+S01123456123456]

30S00000502CB78	15 CHARS	30S	<6 Byte Chip-ID>
+	1 CHAR		
13ZBA2054A.....68	35 CHARS	13Z	<32 Digit Key>
+	1 CHAR		
30PS3001-D350	13 CHARS	30P	<Order code>
+	1 CHAR		
2PDE15	6 CHARS	2P	<2 Stepcode><2 Status>
+	1 CHAR		
Sxxxxxxxxxxxxxxx	15 CHARS	S	<2 Manufacturer><12 DMC>