

## **STM 550 / EMSI (Revision DB / DC)**

### Multisensor For IoT Applications (EnOcean Radio)

06 March 2025



Observe precautions! Electrostatic sensitive devices!

Patent protected:

WO98/36395, DE 100 25 561, DE 101 50 128,  
WO 2004/051591, DE 103 01 678 A1, DE 10309334,  
WO 04/109236, WO 05/096482, WO 02/095707,  
US 6,747,573, US 7,019,241

## STM 550 / EMSI – ENOCEAN MULTISENSOR FOR IOT APPLICATIONS

**REVISION HISTORY**

The following major modifications and improvements have been made to this document:

Version	Author	Reviewer	Date	Major Changes
1.0	MKA	TM, EM, MH, MF	19.02.2020	First public release
1.1	MKA	MKA	18.05.2020	Added description of mechanical interface Added description of product variants
1.2	MKA	MKA	30.06.2020	Added illustration of backup battery interface
1.3	MKA	MKA	03.09.2020	Added ARIB certificate
1.4	MKA	MKA	17.11.2020	Update for revision DB-06
1.5	MKA	MKA	24.06.2021	Added recommendations for selecting the installation location
2.0	MKA	RS	07.06.2024	Update for product revision DC
2.1	MKA	MKA	13.02.2025	Added description regarding acceleration sensor accuracy
2.2	MKA	MKA	06.03.2025	Extended installation instructions Updated product history

**Published by EnOcean GmbH, Kolpingring 18a, 82041 Oberhaching, Germany  
www.enocean.com, info@enocean.com, phone +49 (89) 6734 6890**

© EnOcean GmbH, All Rights Reserved

**Important!**

This information describes the type of component and shall not be considered as assured characteristics. No responsibility is assumed for possible omissions or inaccuracies. Circuitry and specifications are subject to change without notice. For the latest product specifications, refer to the EnOcean website: <http://www.enocean.com>.

As far as patents or other rights of third parties are concerned, liability is only assumed for modules, not for the described applications, processes and circuits.

EnOcean does not assume responsibility for use of modules described and limits its liability to the replacement of modules determined to be defective due to workmanship. Devices or systems containing RF components must meet the essential requirements of the local legal authorities.

The modules must not be used in any relation with equipment that supports, directly or indirectly, human health or life or with applications that can result in danger for people, animals or real value.

Components of the modules are considered and should be disposed of as hazardous waste. Local government regulations are to be observed.

Packing: Please use the recycling operators known to you.

STM 550 / EMSI – ENOCEAN MULTISENSOR FOR IOT APPLICATIONS

**TABLE OF CONTENT**

- 1 General description..... 6
- 1.1 Basic functionality ..... 6
- 1.2 Product variants ..... 7
- 1.3 Technical data..... 8
- 1.4 Environmental conditions ..... 9
- 1.5 Packaging information..... 9
  - 1.5.1 STM 550 ..... 9
  - 1.5.2 EMSI (STM 550 KIT) ..... 9
- 1.6 Ordering information ..... 9
- 2 Functional overview ..... 10
- 2.1 Product overview..... 10
- 2.2 Product interface ..... 10
  - 2.2.1 Front side (STM 550) ..... 11
  - 2.2.2 Front side (EMSI)..... 11
  - 2.2.3 Back side (STM 550) ..... 12
  - 2.2.4 Back side (EMSI) ..... 12
- 2.3 Functional modes ..... 13
  - 2.3.1 Standard Operation mode ..... 13
  - 2.3.2 Standby (Sleep) mode..... 14
  - 2.3.3 Learn mode..... 14
  - 2.3.4 Function Test mode..... 14
  - 2.3.5 Illumination Test mode..... 15
  - 2.3.6 Factory Reset mode ..... 15
- 2.4 Energy management..... 16
- 2.5 Reporting intervals ..... 17
  - 2.5.1 Standard reporting interval ..... 17
  - 2.5.2 Illumination-controlled reporting interval ..... 18
  - 2.5.3 Temperature-controlled reporting interval ..... 19
  - 2.5.4 Humidity-controlled reporting interval ..... 20
  - 2.5.5 Acceleration-controlled reporting interval ..... 21
  - 2.5.6 Magnet contact sensor-controlled reporting interval ..... 22
  - 2.5.7 Arbitration between reporting intervals..... 22
- 3 Sensor functionality ..... 23
- 3.1 Temperature sensor..... 23
- 3.2 Humidity sensor ..... 23
- 3.3 Acceleration sensor..... 24
  - 3.3.1 Wake on acceleration ..... 25
  - 3.3.2 Acceleration sensor parameters ..... 25
  - 3.3.3 Acceleration sensor accuracy ..... 26
- 3.4 Magnet contact sensor ..... 27
- 3.5 Solar cell-based light level measurement..... 27
- 4 User interface ..... 28
- 4.1 Bi-color LED..... 28
- 4.2 LRN button ..... 28

STM 550 / EMSI – ENOCEAN MULTISENSOR FOR IOT APPLICATIONS

4.2.1	LRN button timing .....	29
4.3	Backup battery .....	30
4.3.1	Safety remarks.....	30
4.4	Product label.....	31
4.4.1	Commissioning QR Code.....	31
5	Radio communication.....	32
5.1	Supported EnOcean Equipment Profiles (EEP) .....	32
5.1.1	Default EEP .....	33
5.2	Supported SIGNAL telegram types.....	33
5.2.1	Enabled SIGNAL telegram types .....	33
5.2.2	SIGNAL telegram transmission rate.....	33
6	Security .....	34
6.1	STM 550 security implementation.....	34
7	Commissioning.....	35
7.1	Radio-based commissioning.....	36
7.2	QR code commissioning .....	36
7.3	Commissioning via NFC interface.....	36
8	NFC interface.....	37
8.1	NFC interface parameters .....	37
8.2	NFC access protection .....	37
8.3	Using the NFC interface.....	38
8.3.1	PC with dedicated NFC reader .....	38
8.3.2	Android or iOS smartphone with NFC.....	38
9	Mechanical interface .....	39
9.1	STM 550 .....	39
9.1.1	Top view.....	39
9.1.2	Bottom view.....	40
9.1.3	Cut view (A-A) .....	41
9.1.4	Front view .....	41
9.1.5	Side view.....	42
9.2	EMSI.....	43
10	Installation recommendations .....	44
10.1	Setup instructions .....	44
10.2	Installation location .....	45
10.3	Mounting options (EMSI only) .....	45
10.4	Temperature and humidity sensor .....	46
10.5	Acceleration sensor.....	47
10.5.1	Device orientation use cases .....	47
10.5.2	Device acceleration use cases.....	49
10.5.3	Installation suggestions .....	49
10.6	Light level measurement .....	50
10.7	Magnet contact sensing .....	50
10.8	Energy harvesting .....	50

STM 550 / EMSI – ENOCEAN MULTISENSOR FOR IOT APPLICATIONS

10.9	NFC configuration .....	51
11	Regulatory notes .....	52
11.1	European Union.....	52
11.1.1	Declaration of conformity .....	52
11.1.2	Waste treatment.....	52
11.2	FCC (United States) .....	53
11.2.1	FCC Grant Of Equipment Authorization .....	53
11.2.2	FCC OEM requirements .....	54
11.3	ISED (Industry Canada) .....	55
11.3.1	ISED Technical Acceptance Certificate .....	55
11.3.2	ISED (Industry Canada) regulatory statement .....	56
11.4	ARIB (Japan) .....	57
11.4.1	ARIB construction type conformity certificate .....	57
12	Product history.....	58
A.	Introduction to EnOcean radio protocol .....	59
A.1	ERP1 telegram format.....	59
A.2	ERP2 telegram format.....	60
A.3	Subtelegrams .....	60
A.3.1	Subtelegram timing .....	61
A.3.2	TX maturity time .....	62
A.3.3	RX maturity time .....	62
A.4	Addressing .....	63
A.4.1	Address types .....	63
A.4.2	EURID (Radio ID) .....	64
A.4.3	Broadcast ID.....	64
A.4.4	Base ID .....	64
A.5	Data payload .....	65
A.5.1	EnOcean Equipment Profiles (EEP) structure .....	65
A.5.2	Common RORG .....	66
A.5.3	Data payload size .....	67
A.6	Telegram chaining .....	67
A.6.1	Telegram chaining for broadcast telegrams.....	68
A.6.2	Telegram chaining for addressed telegrams (ADT) .....	68
A.6.3	Telegram chaining for secure telegram (SEC_CDM) .....	69
A.6.4	Telegram chaining for addressed secure telegram (ADT SEC_CDM) .....	70
B.	Introduction to EnOcean security protocol .....	71
B.1	Goals of secure radio communication .....	71
B.2	Telegram encryption .....	72
B.3	Telegram authentication.....	72
B.4	Replay protection .....	74
B.4.1	RLC and security key in bi-directional communication .....	76
B.4.2	RLC synchronization between sender and receiver .....	77
B.4.3	Secure telegram types .....	78
B.4.3.1	Secure teach-in telegram .....	78
B.4.3.2	Teach-in Info .....	79
B.4.3.3	Security level format (SLF) .....	79

STM 550 / EMSI – ENOCEAN MULTISENSOR FOR IOT APPLICATIONS

---

## 1 General description

This user manual describes the functionality of the STM 550 EnOcean multisensor in the following frequency variants and revisions:

- STM 550 (Revision DC)  
868.3 MHz radio (main market Europe)
- STM 550U (Revision DB)  
902.875 MHz radio (main market US / Canada)
- STM 550J (Revision DB)  
928.35 MHz radio (main market Japan)

For documentation regarding previous revisions, please contact EnOcean GmbH. The term “STM 550” is used throughout this user manual to describe all variants unless otherwise noted.

### 1.1 Basic functionality

STM 550 is a flexible self-powered multisensor module family capable of measuring temperature, humidity, illumination, magnet contact status and acceleration. It enables the realization of energy harvesting wireless sensors for light, building or industrial control systems communicating using the EnOcean radio standard.

STM 550 uses the same mechanical form factor as the industry standard PTM 21x modules from EnOcean. STM 550 measures and reports the following data:

- Temperature
- Humidity
- Illumination (measured via the calibrated solar cell)
- Acceleration
- Magnet contact status

STM 550 will report periodically (by default approximately every 2 minutes, configurable via NFC) the latest measurements of these sensors. In addition, STM 550 can also report its internal energy level and the status of the backup battery (if present).

STM 550 will report immediately if the status (open / closed) of the magnet contact changes or if a change in acceleration measured by the acceleration sensor exceeds a user-defined threshold for the first time.

Radio telegrams transmitted by STM 550 can be encrypted and authenticated using AES-128 security based on a device-unique private key and a sequence counter in accordance with the EnOcean Alliance Security Specification. This ensures integrity, confidentiality and authenticity of the transmitted telegrams and prevents telegram replay (retransmission of previously transmitted telegrams).

STM 550 is self-supplied via an integrated solar cell which generates the energy required for its operation. For cases where ambient light is not sufficiently available, STM 550 provides the option to mount a CR1632 backup battery.

STM 550 / EMSI – ENOCEAN MULTISENSOR FOR IOT APPLICATIONS

---

## 1.2 Product variants

STM 550 is available in two different product variants:

- STM 550 is the multisensor module in original PTM module form factor intended for integration into OEM housings. It is delivered in tray and box packaging of 100 units per box.
- STM 550 Installation Kit combines the STM 550 multisensor module with a wall mount, a design frame, a magnet (for magnet sensor functionality) and an adhesive mounting tape into a ready to use product (EMSI). It is provided in tray and box packing of 100 units per box.

Figure 1 below shows the STM 550 module on the left and EMSI on the right.



**Figure 1 – STM 550 (left) and EMSI (right)**

## STM 550 / EMSI – ENOCEAN MULTISENSOR FOR IOT APPLICATIONS

**1.3 Technical data**

<b>Antenna</b>	Integrated antenna
<b>Transmission frequency / power</b>	STM 550: 868.300 MHz / +10 dBm STM 550U: 902.875 MHz / + 99 dBμV STM 550J: 928.350 MHz / 0 dBm
<b>Transmission data rate</b>	125 kbit/s
<b>Communication range (for guidance only)</b>	200 m free field Up to 30 m in indoor environment
<b>Temperature measurement range / accuracy</b>	-5 °C ... +45 °C / +- 0.3 K
<b>Humidity measurement range / accuracy</b>	0 ... 90 % r.h. / +- 3% r.h.
<b>Illumination measurement range / accuracy</b>	0 ... 2000 lux / ± 5 % of full scale
<b>Acceleration measurement range / accuracy</b>	+ - 2 g / ± 5 % of full scale
<b>Acceleration threshold for immediate report</b>	0.03 g
<b>Update rate (excl. random offset)</b>	Every 2 minutes
<b>Device configuration</b>	LRN button and NFC interface
<b>User notification</b>	Bi-color LED (red, green)
<b>Supported EEP</b>	D2-14-41 (default) D2-14-40, A5-02-05, A5-04-01, A5-04-03 A5-06-02, A5-06-03, A5-14-05, D5-00-01
<b>Power supply</b>	Integrated solar cell
<b>Minimum light level for self-supplied operation</b>	200 lux for 6 hours per day
<b>Operating time in darkness</b>	4 days after full charge
<b>Backup power supply (optional)</b>	CR1632
<b>Operation time with backup battery</b>	Renata CR1632 (137 mAh)
Infrequent bright light (200 lux for 2 hrs per day)	7 years
Consistent low light (50 lux for 6 hrs per day)	6 years
Total Darkness	4.5 years
<b>Dimensions (STM 550 module)</b>	40 mm x 40 mm x 13 mm
<b>Dimensions (EMSI finished product)</b>	49 mm x 49 mm x 13 mm

Notes: STM 550B is designed for indoor use only and should only be used in the specified environmental conditions  
If a parameter depends on the device configuration, then the value corresponding to default settings is provided



## STM 550 / EMSI – ENOCEAN MULTISENSOR FOR IOT APPLICATIONS

### 1.4 Environmental conditions

<b>Operating Temperature</b>	-5 °C ... +45 °C (indoor use in dry rooms only)
<b>Humidity</b>	0% to 90% r.h. (non-condensing)

### 1.5 Packaging information

#### 1.5.1 STM 550

STM 550 is delivered in a box of 100 units packed onto 10 trays of 10 units each.

<b>Packaging Unit</b>	100 units
<b>Packaging Method</b>	10 modules per tray, 10 trays per box
<b>Tray Dimensions</b>	205 mm x 166 mm x 20 mm
<b>Box Dimensions</b>	205 mm x 176 mm x 174 mm

#### 1.5.2 EMSI (STM 550 KIT)

EMSI is delivered in an installation kit consisting of one box with 100 units STM 550 modules (as described above) together with one box of 100 units of installation material.

<b>Packaging Unit</b>	100 units
<b>Packaging Method</b>	1 large outer box containing 2 smaller inner boxes Inner box 1: 100 units STM 550 (same as above) Inner box 2: 100 units installation material
<b>Outer Box Dimensions</b>	360 mm x 234 mm x 178 mm
<b>Inner Box Dimensions</b>	232 mm x 176 mm x 174 mm

### 1.6 Ordering information

Product	Type	Ordering Code	Frequency
<b>STM 550</b>	STM 550	S6201-K516:DC	868.300 MHz
<b>STM 550U</b>	STM 550 module only	S6251-K516:DB	902.875 MHz
<b>STM 550J</b>	Delivered in 100-unit packaging	S6261-K516:DB	928.350 MHz
<b>STM 550 KIT</b>	EMSI (STM 550 Installation Kit)	B6201-K516:DC	868.300 MHz
<b>STM 550U KIT</b>	STM 550 module with housing and installation material	B6251-K516:DB	902.875 MHz
<b>STM 550J KIT</b>	Delivered in 100-unit packaging	B6261-K516:DB	928.350 MHz

STM 550 / EMSI – ENOCEAN MULTISENSOR FOR IOT APPLICATIONS

---

## 2 Functional overview

### 2.1 Product overview

The energy-harvesting multisensor module STM 550 provides wireless sensing functionality without batteries.

STM 550 operates fully self-powered (no batteries required) when sufficient available ambient light (200 Lux for 6 hours per day) is available. The required energy for operation is harvested by an integrated solar cell. In this configuration, STM 550 operates fully maintenance-free.

For cases where sufficient ambient light is not available there is the option to mount a CR1632 backup battery.

STM 550 periodically measures temperature, humidity, ambient light level, magnet contact status and acceleration and reports the status using radio telegrams according to EnOcean Alliance radio specification.

Radio telegrams transmitted by STM 550 can be authenticated and encrypted using AES-128 security based on a device-unique private key and a sequence counter in accordance with the EnOcean Alliance Security Specification.

The user interface of STM 550 consists of one button for simple configuration tasks and one bi-color LED to provide user feedback. Configuration of STM 550 parameters is also possible via an integrated NFC (ISO 14443) interface using a PC tool or a mobile application.

### 2.2 Product interface

The STM 550 product interface consists of the following elements:

- LRN button and bi-color LED
- Solar cell to harvest energy from ambient light and measure the ambient light level
- Magnet contact sensor
- Ventilation slots to ensure airflow to the temperature and humidity sensor
- Backup battery slot for a CR1632 battery
- Backup battery ejector slot (on the back side)
- Product label (on the back side)

STM 550 / EMSI – ENOCEAN MULTISENSOR FOR IOT APPLICATIONS

**2.2.1 Front side (STM 550)**

Figure 2 below shows the external interfaces on the front side of the STM 550 module.

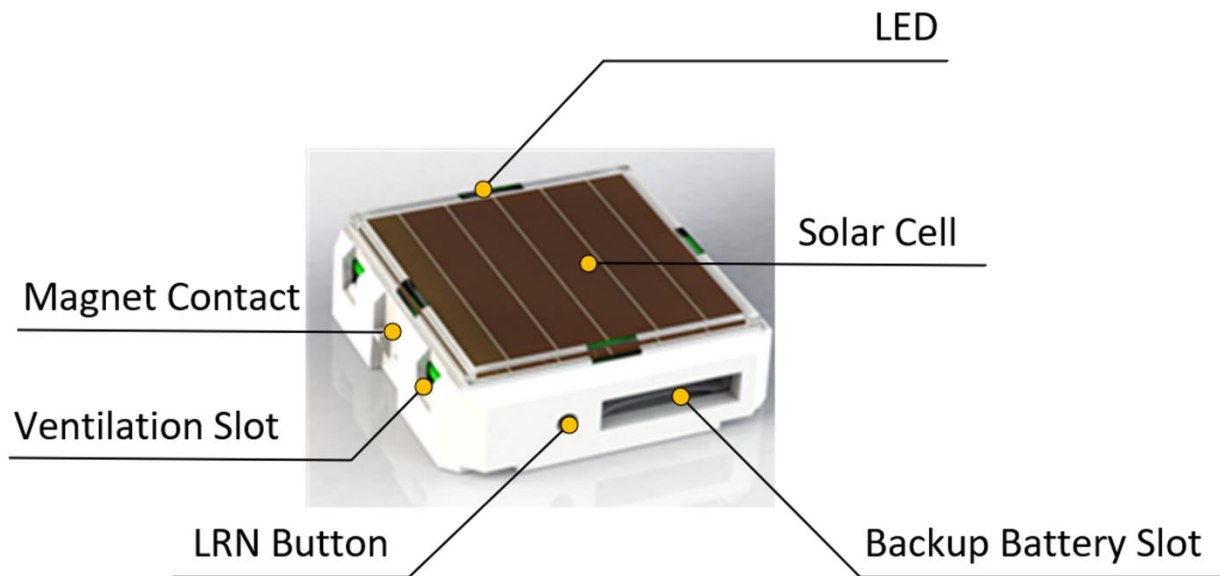

**Figure 2 – STM 550 product interface (front side)**

**2.2.2 Front side (EMSI)**

Figure 4 below shows the external interfaces on the front side of the assembled EMSI product (STM 550 module combined with the design frame and the wall mount provided by STM 550 KIT).

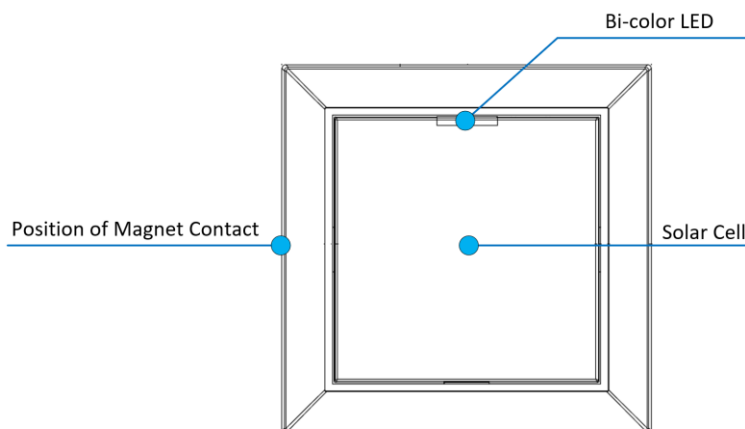
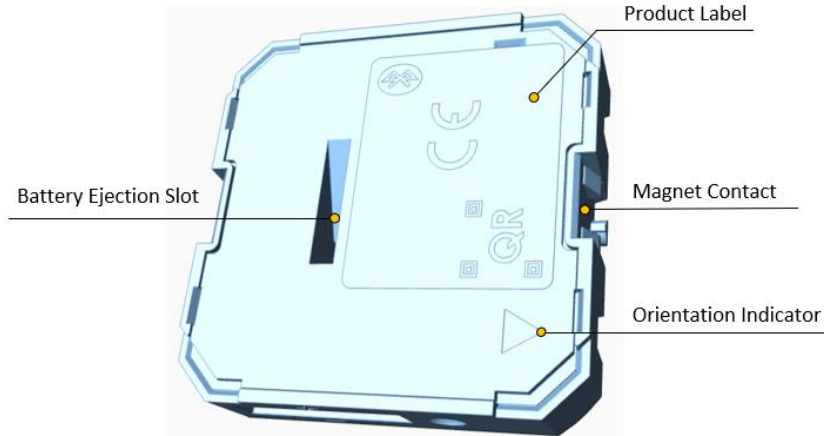

**Figure 3 – EMSI product interface (front side)**

STM 550 / EMSI – ENOCEAN MULTISENSOR FOR IOT APPLICATIONS

**2.2.3 Back side (STM 550)**

Figure 4 below shows the external interfaces on the back side of the STM 550 module. The orientation indicator points towards the side where the magnet contact is located.



**Figure 4 – STM 550 product interface (back side)**

**2.2.4 Back side (EMSI)**

Figure 5 below shows the external interfaces on the back side of the assembled EMSI product. The orientation indicator points towards the side where the magnet contact is located. The ventilation slots ensure air flow towards the temperature and humidity sensor and should not be obstructed if EMSI is used to measure temperature or humidity.

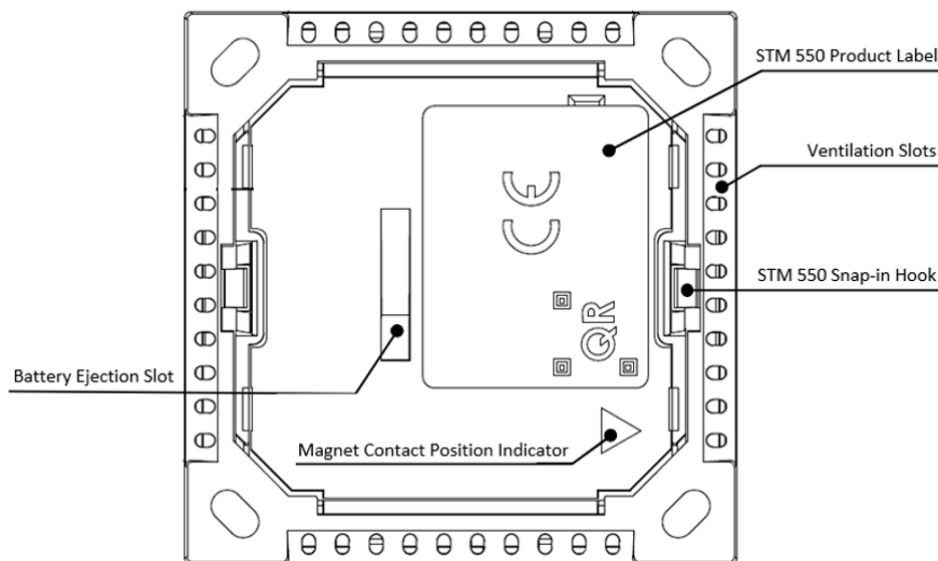

**Figure 5 – EMSI product interface (back side)**

STM 550 / EMSI – ENOCEAN MULTISENSOR FOR IOT APPLICATIONS

---

## 2.3 Functional modes

STM 550 supports six functional modes:

- Standard Operation mode
- Standby (Sleep) mode
- Learn mode
- Function Test mode
- Illumination Test mode
- Factory Reset mode



Out of the box (factory-new), STM 550 is configured to be in Standby mode to conserve energy during transport and storage and to comply with regulation regarding radio transmissions during transport.

Upon initial setup, STM 550 has to be set to Standard Operation mode by exposing it to light and pressing the LRN button shortly as described in chapter 10.1 or via the NFC interface described in chapter 8.

### 2.3.1 Standard Operation mode

During standard (normal) operation, STM 550 wakes up periodically and reports the current sensor status using data telegrams. The STM 550 wake-up timer is by default configured to wake-up STM 550 approximately every 2 minutes. The wake-up intervals are affected at random (meaning that a small random offset is added to the timing interval) to increase the robustness of the radio transmission and to comply with regulatory requirements.

If acceleration exceeding the configured threshold is detected for the first time after a period without exceeding this threshold, then STM 550 wakes up immediately (wake on acceleration event). Likewise, if the status of the magnet contact changes (from open to closed or vice versa) then this is reported immediately as well (wake on magnet contact event).

STM 550 / EMSI – ENOCEAN MULTISENSOR FOR IOT APPLICATIONS

---

### 2.3.2 Standby (Sleep) mode

Standby (Sleep) mode is the lowest power mode of STM 550 and is the out of the box state of STM 550 upon delivery. It is intended to be used during extended periods without operation such as device storage or transport. In standby mode, STM 550 stops operation and conserves as much energy as possible. All functionality – except those needed to return to standard operation mode – are disabled in this mode.

Standby mode can be selected using the LRN button as described in chapter 4.2 or using the NFC interface described in chapter 8. Upon entering standby mode, STM 550 will send a SIGNAL telegram of type 0x0E as described in chapter 5.2.

### 2.3.3 Learn mode

In Learn mode, STM 550 will transmit the required information to decode its data telegrams and to communicate securely to the receiver.

If STM 550 operates in high security mode, then it will first transmit a Secure Teach-In (SEC\_TI) telegram to the receiver containing information about the selected security mode and the currently used security credentials to a receiver. The format of the SEC\_TI telegram is described in Appendix B.4.3.1.

After that, STM 550 will transmit a Teach-in telegram to communicate its source address (EURID), the EnOcean Equipment Profile (EEP) that it currently uses. If STM 550 operates in high security mode, then this telegram will be transmitted using the security mode and the security credentials specified in the Secure Teach-in telegram.

After that, STM 550 will return to Standard Operation mode.

Learn mode can be selected using the LRN button as described in chapter 4.2 or using the NFC interface as described in chapter 8.

### 2.3.4 Function Test mode

In Function Test mode, STM 550 will measure and report the status of the integrated sensors (according to the currently selected EEP) at a lower interval (i.e. faster update rate) of approximately 3 seconds to allow users verifying the sensor functionality.

If Function Test mode is active and an EEP with acceleration detection is selected, then the status of the acceleration detection is reported by the LED (green = acceleration detected, red = no acceleration detected).

STM 550 can be set into Function Test mode via the LRN button as described in chapter 4.2 or using the NFC interface as described in chapter 8.

Function Test mode will be active for approximately 2 minutes; it will be stopped immediately if the LRN button is pressed or if the functional mode is changed via the NFC interface.

STM 550 / EMSI – ENOCEAN MULTISENSOR FOR IOT APPLICATIONS

---

### 2.3.5 Illumination Test mode

During installation, STM 550 can measure and report the level of available ambient light using its solar cell to select a suitable installation location as discussed in chapter 10.7 by means of Illumination Test mode.

Illumination Test mode can be activated via the NFC interface as described in chapter 8. Activation of Illumination Test mode will be indicated by the LED of STM 550 using a green blink followed by a red blink.

Upon activation of Illumination Test mode, STM 550 will first wait for 20 seconds so that the installer can vacate the area in front of the sensor to ensure an accurate measurement result. STM 550 will indicate this waiting period using red blinks at a rate of one blink every 3 seconds.

After that, STM 550 will take measurements of the ambient light level using its solar cell every 5 seconds for a period of approximately one minute and indicate each measurement using a green blink.

After completion of the measurements, STM 550 will compute the average illumination based on those measurements. STM 550 will signal the completion of the Illumination Test using a green blink followed by a red blink and the computed average illumination can then be read-out via the NFC interface as described in chapter 8.

After completion of Illumination Test mode, STM 550 will continue operation in Standard Operation mode.

### 2.3.6 Factory Reset mode

STM 550 can be reset to its standard settings using Factory Reset mode. Upon entering this mode, STM 550 will reset all configuration registers to their default settings and then restart operation in standard operation mode.

Factory Reset mode can be selected using the LRN button as described in chapter 4.2 or using the NFC interface as described in chapter 8.

Note that Factory Reset mode is not available under the following conditions:

- STM 550 is in Standby mode and the LRN button is used to trigger Factory Reset  
Factory Reset by LRN button action is not available during Standby (Sleep) mode to prevent unintended wake-up.
- STM 550 has insufficient available energy  
Factory reset is not available if the available energy in STM 550 is insufficient to safely execute this operation. STM 550 will signal that the available energy is insufficient by blinking 5 times red.

Upon entering Factory Reset mode, STM 550 will reset all configuration registers to their default settings, restart operation in standard operation mode and indicate successful completion of this procedure by blinking 5 times green.

## 2.4 Energy management

The standard reporting interval of 120 seconds (one update every 2 minutes) is adjustable using the NFC interface. The minimum possible reporting interval is 3 seconds, and the maximum possible transmission interval is 65535 seconds.

Lowering the reporting interval of STM 550 will increase its power consumption since it will measure and transmit more often. Likewise, increasing the reporting interval of STM 550 will reduce its power consumption since it will measure and transmit less often.

STM 550 will measure the available energy and stop operation if this is insufficient to execute the required functions. Specifically, STM 550 will stop operation of the sensors and not transmit radio telegrams under such low energy conditions.

Additionally, STM 550 will not update the device configuration via NFC, execute a Function Test, an Illumination Test or a Factory Reset if the available energy is insufficient.

STM 550 will re-evaluate available energy approximately every 60 seconds, restart operation and re-accept Function Test, Illumination Test, Factory Reset or NFC configuration update requests once the energy level becomes sufficient.



## 2.5 Reporting intervals

### 2.5.1 Standard reporting interval

In absence of external events, STM 550 will transmit its status as data telegram at a regular interval which is defined by the parameter STANDARD\_TX\_INTERVAL.

By default, STANDARD\_TX\_INTERVAL is set to 120 seconds, i.e. STM 550 will measure and report its status approximately once every 2 minutes. The value of STANDARD\_TX\_INTERVAL can be configured via the NFC interface as described in chapter 8.

Lowering the reporting interval of STM 550 will increase its power consumption since it will measure and transmit more often. Likewise, increasing the reporting interval of STM 550B will reduce its power consumption since it will measure and transmit less often.

STM 550 is designed to apply fluctuations up to +/-10% to transmission intervals to increase transmission reliability and meet regulatory requirements.

STM 550 will report the initial acceleration detection after a period without detected acceleration immediately. Likewise, STM 550 will report any change in the status of the magnet contact sensor (open -> closed or closed -> open) immediately.

STM 550 can be configured to automatically use a lower reporting interval, i.e. provide updates more often, based on certain conditions as described in the subsequent chapters.

Figure 6 below illustrates the use of STANDARD\_TX\_INTERVAL.

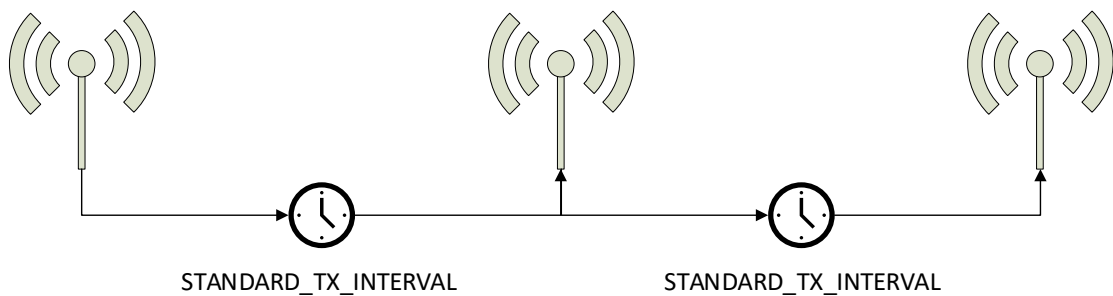

**Figure 6 – Standard reporting interval**

### 2.5.2 Illumination-controlled reporting interval

If sufficient ambient light is available, then it might be desirable to receive status updates more often. For this, there are typically two main use cases:

- Adjust the update rate based on the ambient light available for harvesting
- Report more often during daytime (or when an office is lit) and less often during night-time (or when an office is dark) to adapt the reporting to the usage pattern

For such cases, STM 550 can be configured to use a higher update rate whenever the ambient light level (measured by the solar cell) is above a certain threshold.

The higher update rate is defined by `SOLAR_TX_INTERVAL` and the threshold above which this higher update rate is used is defined by `SOLAR_TX_TRESHOLD`. These parameters can be configured via the NFC interface as described in chapter 8.

Figure 7 below illustrated the use of the illumination-controlled reporting interval.

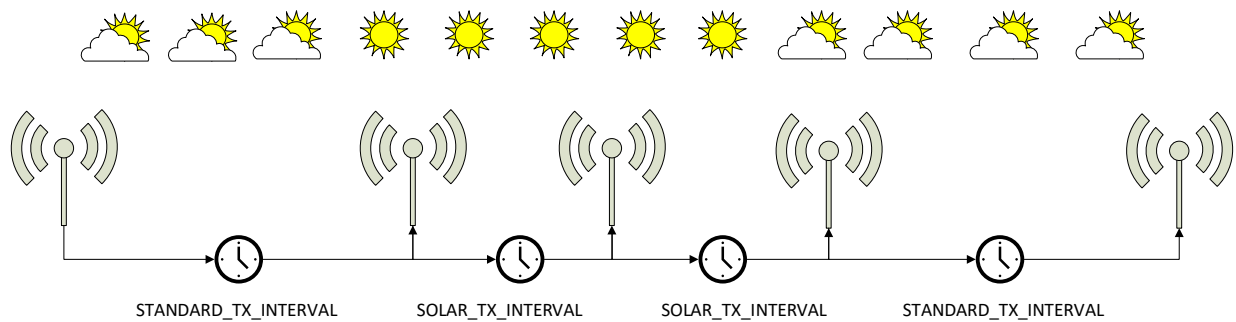

**Figure 7 – Illumination-controlled reporting interval**

### 2.5.3 Temperature-controlled reporting interval

In HVAC (heating, ventilation, air conditioning) or in temperature monitoring applications, it might be desirable to receive status updates more often if the measured temperature is above or below a certain threshold.

For such cases, STM 550 can be configured to use a higher update rate whenever the measured temperature is either above or below a certain threshold.

The higher update rate is defined by `TEMPERATURE_TX_INTERVAL` and the threshold above or below which this higher update rate is used is defined by `TEMPERATURE_TX_TRESHOLD`. These parameters can be configured via the NFC interface as described in chapter 8.

Figure 8 below illustrates the use of the temperature-controlled reporting interval.

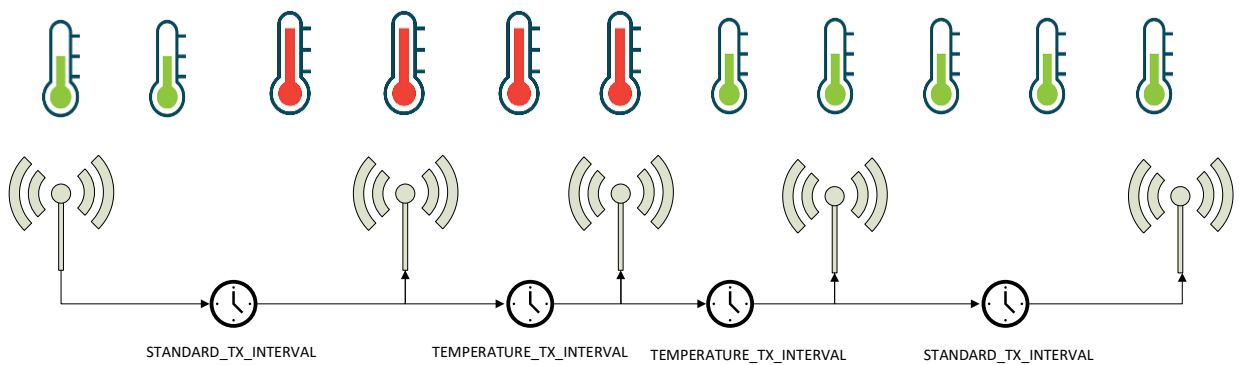

**Figure 8 – Temperature-controlled reporting interval**

### 2.5.4 Humidity-controlled reporting interval

In HVAC (heating, ventilation, air conditioning) applications it might be desirable to receive status updates more often if the measured humidity is significantly above or below the target value.

For such cases, STM 550 can be configured to use a higher update rate whenever the measured humidity is either above or below a certain threshold.

The higher update rate is defined by `HUMIDITY_TX_INTERVAL` and the threshold above or below which this higher update rate is used is defined by `HUMIDITY_TX_TRESHOLD`. These parameters can be configured via the NFC interface as described in chapter 8.

Figure 9 below illustrates the use of the humidity-controlled reporting interval.

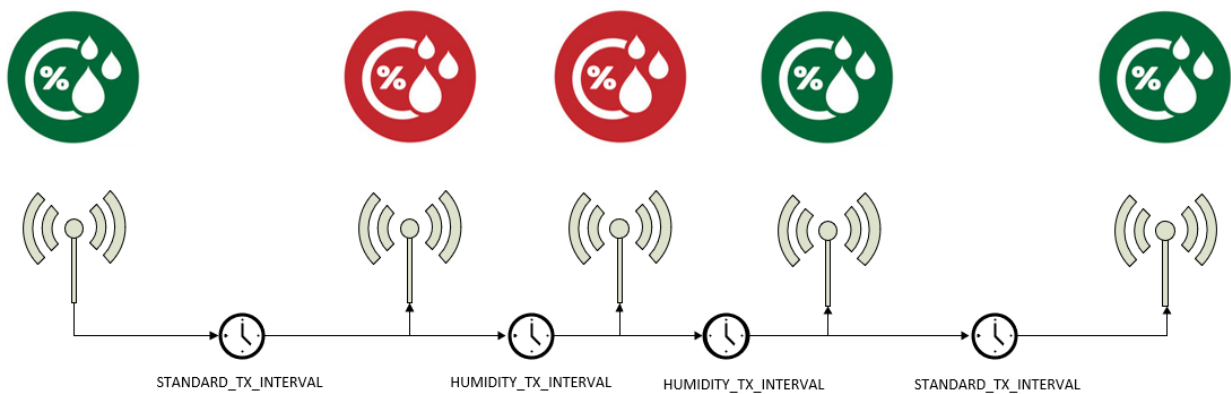

**Figure 9 – Humidity-controlled reporting interval**

### 2.5.5 Acceleration-controlled reporting interval

If an asset is in operation or it is being moved, then it might be desirable to receive status updates more often to determine its status or location.

For such cases, STM 550 can be configured to use a higher update rate whenever the measured acceleration is above a certain threshold.

The higher update rate is defined by `ACCELERATION_TX_INTERVAL` and the threshold above or below which this higher update rate is used is defined by `ACCELERATION_TX_TRESHOLD`. These parameters can be configured via the NFC interface as described in chapter 8.

Figure 10 below illustrates the use of the acceleration-controlled reporting interval.

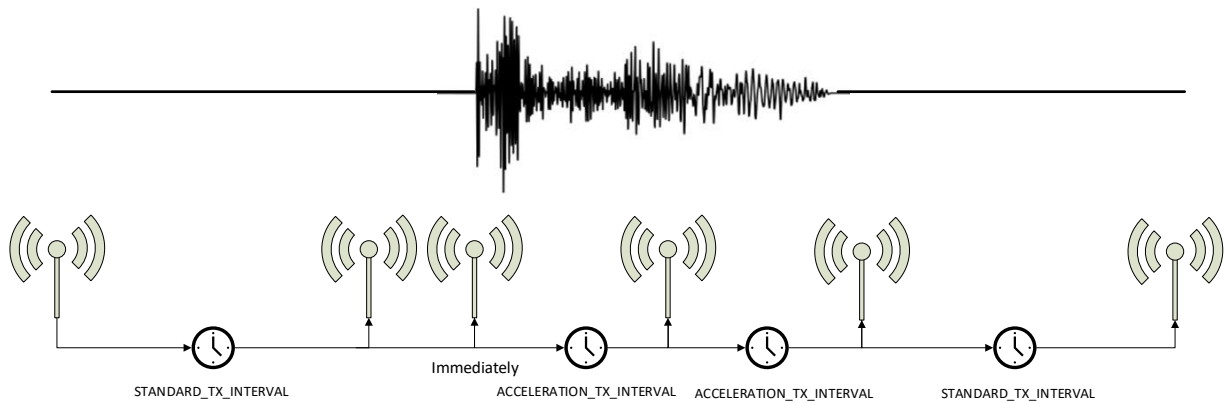

**Figure 10 – Acceleration-controlled reporting interval**

### 2.5.6 Magnet contact sensor-controlled reporting interval

If a door or a window is opened when it normally should be closed (or vice versa), then it might be desirable to receive status updates more often to monitor its status.

STM 550B can therefore be configured to use a lower reporting interval, i.e. a higher update rate, for one of the two magnet contact sensor status options (open or closed).

The higher update rate is defined by CONTACT\_TX\_INTERVAL and the state (open or closed) where the higher update rate is used is defined by CONTACT\_TX\_STATE. These parameters can be configured via the NFC interface as described in chapter 8.

Figure 11 below illustrates the use of the magnet contact sensor-controlled reporting interval for the case where a higher update rate applies if the magnet contact state is open.

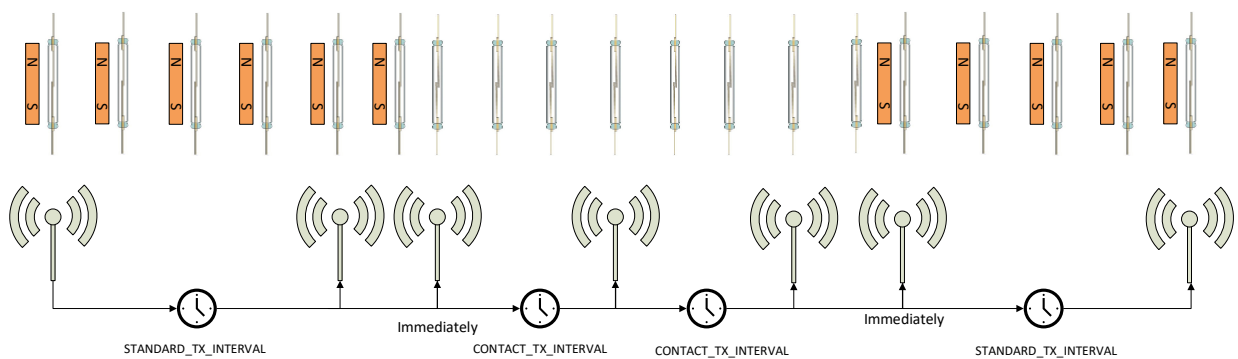

**Figure 11 – Magnet contact sensor-controlled reporting interval**

### 2.5.7 Arbitration between reporting intervals

If more than one condition for a lower reporting interval applies – e.g. if both an acceleration exceeding the acceleration threshold is detected and the light level is higher than the light level threshold – then the lowest of the corresponding reporting intervals will be selected.

STM 550 / EMSI – ENOCEAN MULTISENSOR FOR IOT APPLICATIONS

### 3 Sensor functionality

STM 550 integrates a set of sensors used to measure environmental parameters. The following chapters described their characteristics in detail.

#### 3.1 Temperature sensor

STM 550 integrates a high-performance temperature sensor achieving accuracy of better than  $\pm 0.3$  °C throughout the entire operation temperature range and an accuracy of better than  $\pm 0.2$  °C for the typical indoor temperature range.

Figure 12 below shows the typical accuracy of the STM 550 temperature sensor as a function of the ambient temperature. To determine the overall system accuracy, the quantization error (reporting step size) determined by the selected EnOcean Equipment Profile (EEP) must be added to this value and the airflow design has to be considered.

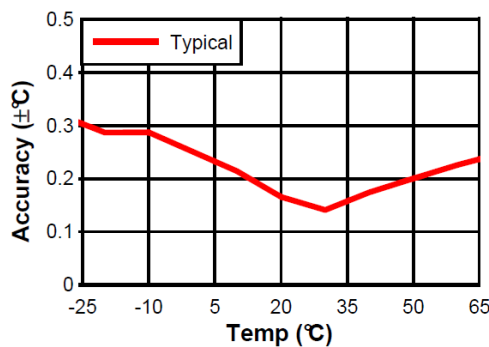

Figure 12 – Temperature sensor accuracy

#### 3.2 Humidity sensor

STM 550 integrates a high-performance humidity sensor achieving accuracy of better than  $\pm 3$  % r.h. throughout the entire operation temperature range and an accuracy of better than  $\pm 2$  % r.h. for the typical indoor humidity range.

Figure 13 below shows the typical accuracy of the STM 550 humidity sensor as a function of the ambient humidity. To determine the overall system accuracy, the quantization error (reporting step size) determined by the selected EnOcean Equipment Profile (EEP) has to be added to this value and the airflow design has to be considered.

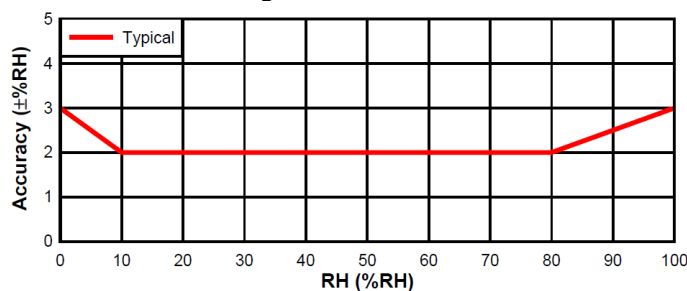

Figure 13 – Humidity sensor accuracy

## STM 550 / EMSI – ENOCEAN MULTISENSOR FOR IOT APPLICATIONS

### 3.3 Acceleration sensor

STM 550 integrates an acceleration sensor which provides two types of data:

- Acceleration vector orientation  
This allows determining the direction into which STM 550 is either accelerated (moved) or permanently oriented (positioned relative to the earth gravity vector). See Chapter 10.5.1 for an example.
- Acceleration vector change  
This allows determining if STM 550 is moved or shaken

The second case (acceleration vector change) can be used to determine the presence or absence of small vibrations (acceleration vector changes). Examples use cases causing such small vibrations include asset utilization (e.g. a motor to which STM 550 is attached is running) or asset movement (e.g. an asset to which STM 550 is attached changes its location).

If such change in acceleration is above a certain threshold, then this will be reported as part of the regular data telegram. If the acceleration exceeds this threshold for the first time, then this will be reported immediately (wake-on-acceleration).

Figure 14 below shows the orientation of the reported acceleration vector relative to STM 550. This means that:

- If STM 550 was be positioned stationary on a flat surface parallel to the earth surface with the solar cell oriented away from the earth surface (STM 550 "laying" on the device label side, like in the illustration below), then STM 550 would report:  
 $x = 0g$ ;  $y = 0g$ ;  $z = 1g$  (earth gravity)
- If STM 550 was be positioned stationary on a flat surface parallel to the earth surface with the battery insertion slot oriented towards the earth surface (STM 550 "standing" on the battery insertion slot), then STM 550 would report:  
 $x = 0g$ ;  $y = -1g$  (earth gravity);  $z = 0g$

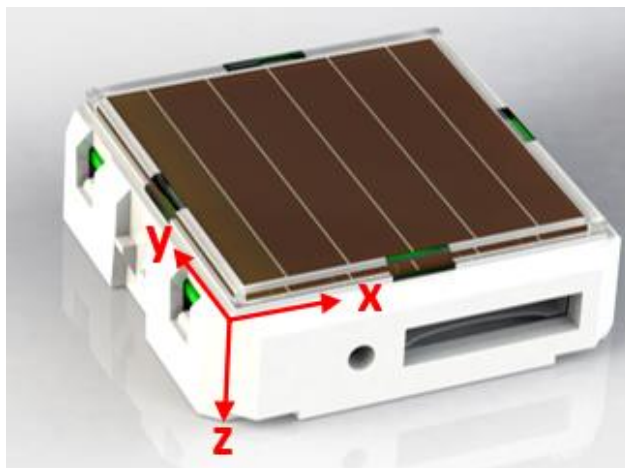

**Figure 14 – Acceleration sensor orientation**



STM 550 / EMSI – ENOCEAN MULTISENSOR FOR IOT APPLICATIONS

### 3.3.1 Wake on acceleration

If the last status reported by STM 550 was that acceleration is below the acceleration threshold and the acceleration exceeds this threshold after that report, then STM 550 can be configured to wake up immediately and report this status. This mechanism is called a wake on acceleration.

Wake on acceleration can be enabled and disabled via NFC; it is enabled by default. The threshold and the sampling rate used for detecting such wake on acceleration event can be configured via NFC as described below.

### 3.3.2 Acceleration sensor parameters

The acceleration sensor integrated in STM 550 allows configuring the following parameters:

- Full-scale magnitude  
 The full-scale magnitude determines the maximum acceleration magnitude that will be reported. Higher settings allow reporting higher magnitudes but will result in less resolution and thereby less sensitivity. The default full scale magnitude of  $\pm 2g$  should be appropriate for most use cases.
- Acceleration threshold  
 The acceleration threshold determines the threshold of acceleration vector change required to trigger a wake-on vibration event as described above or to reduce the transmission interval as described in chapter 2.5.5. Setting a lower acceleration threshold results in a higher sensitivity to acceleration vector changes. STM 550 uses by default the minimum possible threshold corresponding to  $1/64$  of its full-scale magnitude.
- Sampling rate  
 The sampling rate determines how often the acceleration vector will be measured. Higher sampling rates allow detecting shorter vibrations but require more energy to do so. Higher sampling rates should only be used if minor vibrations are not detected when using the minimum acceleration threshold.

Table 1 below shows the supported configuration options for each of these parameters and their default settings in STM 550.

Parameter	Supported Options (bold = default)
Full-scale magnitude	<b><math>\pm 2g</math></b> , $\pm 4g$ , $\pm 8g$ , $\pm 16g$
Acceleration threshold	<b><math>1/64</math></b> ... $63/64$ of full scale
Sampling rate	$1.6\text{ Hz}$ , <b><math>12.5\text{ Hz}</math></b> , $25\text{ Hz}$ , $50\text{ Hz}$
Measurement resolution	10 bit for each (x, y, z) direction

**Table 1 – Acceleration sensor parameters**



Note that increasing the sampling rate will proportionally increase the power consumption of STM 550. The sampling rate should only be increased if sufficient ambient light is available or if a backup battery is used.

STM 550 / EMSI – ENOCEAN MULTISENSOR FOR IOT APPLICATIONS

---

### 3.3.3 Acceleration sensor accuracy

The acceleration sensor in STM 550 is optimized to detect vibrations or significant changes in its orientation relative to earth gravity. Chapter 10.5 describes typical acceleration sensor use cases.

The accuracy of the reported acceleration sensor values is determined by a wide range of parameters including the following:

- Housing to surface alignment  
STM 550 might be attached to a surface by means of adhesive tape or by screwing as described in chapter 10.3. Both ways of attachment may result in alignment errors where the sensor is not fully parallel to the mounting surface.
- PCB to housing alignment  
The acceleration sensor is mounted on a PCB which held in place by fixation point on the bottom housing. This fixation allows for travel of the PCB relative to the housing to avoid mechanical stress in case of thermal expansion.
- Sensor to PCB alignment  
The PCB on which the acceleration sensor is mounted will experience thermal expansion and contraction if the ambient temperature rises or falls. The rate of thermal expansion or contraction of the PCB is different from that of the sensor which can result in a mechanical force from the PCB towards the sensor affecting the sensor readings.
- Ambient temperature changes  
Changes in ambient temperature can cause expansion or contraction of the acceleration sensor, the STM 550 PCB, the STM 550 housing and the equipment to which STM 550 is attached (desk, door, window, machinery, etc.).
- Sensor reporting resolution  
STM 550 reports the measured acceleration value using 10-bit encoding covering a  $\pm 2.5$  g interval according to EEP D2-14-41 as described in chapter 5.1 which limits the resolution of reported values.

The combined effect of the above points can limit the accuracy of the reported acceleration sensor status to  $\pm 5\%$  of the full-scale value.

STM 550 / EMSI – ENOCEAN MULTISENSOR FOR IOT APPLICATIONS

### 3.4 Magnet contact sensor

STM 550 integrates a magnet contact sensor detecting presence or absence of a magnetic field in the proximity of the sensor. Refer to Chapter 2.2 for the location of the magnet contact sensor within STM 550 and to Chapter 10.7 for mounting instructions.

EMSI product packaging includes a block magnet suitable for use with its magnet contact sensor. Figure 15 shows the outer appearance of this magnet.

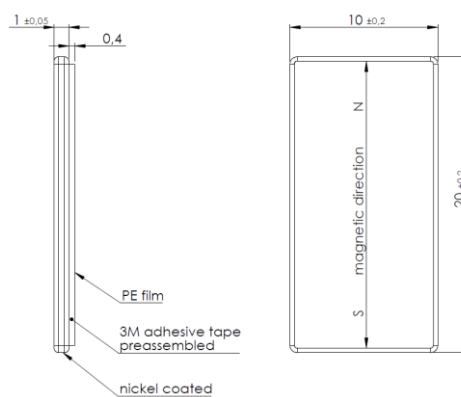

**Figure 15 – Magnet outline**

The magnet is made from N35 grade Neodymium material. Table 2 below lists the key parameters of this material for reference if use of alternative magnets is planned.

	Br		Hcb		Hcj		(BH) <sub>max</sub>		TW
	T	KGs	KA/m	KOe	KA/m	KOe	KJ/m <sup>3</sup>	MGOe	°C
N35	1.17-1.21	11.7-12.1	876-899	11.0-11.3	≥955	≥12	263-279	33-35	≤80

**Table 2 – N35 material parameters**

### 3.5 Solar cell-based light level measurement

STM 550 uses the calibrated solar cell response to measure and report the ambient light level. This approach is designed for reporting indoor lighting conditions between 0 and 2000 lux with an accuracy of ± 5% of the full-scale value.

STM 550 / EMSI – ENOCEAN MULTISENSOR FOR IOT APPLICATIONS

## 4 User interface

The STM 550 product interface contains a bi-color LED, a LRN button and a backup battery interface as described in chapter 2.2.

### 4.1 Bi-color LED

STM 550 contains a bi-colour (red / green) indication LED used to provide user feedback. By default, the LED will blink shortly whenever a telegram is transmitted. This indication can be disabled using the NFC interface as described in chapter 8. In addition to that, the LED provides a response to LRN button inputs as described below.

### 4.2 LRN button

STM 550 device parameters can be configured using the NFC interface which is described in chapter 8. Some of the most common parameters or states can additionally be configured using the LRN button.

Table 3 below lists those LRN button actions with the corresponding STM 550 response and LED feedback.

Event / User Action	Action	LED Indication
<i>Telegram Transmission</i> (No Button Action)	<b>Data Telegram Transmission</b> Indication of data telegram transmission	1 blink green
<i>NFC Configuration</i> (Not Button Action)	<b>NFC Configuration Event</b> Configuration Update via NFC  Factory Reset via NFC	Config Success: 4 blink green Config Error: 4 blink red  Reset Success: 5 blink green Reset Error: 5 blink red
<i>Single Short Press</i> (Press < 1s)	<b>LRN Telegram Transmission</b> <i>If in Standard Mode:</i> Send Standard LRN Telegram  <i>If in High Security Mode:</i> Send Security LRN Telegram  <i>If in Sleep Mode:</i> Wake up to Standard Mode Send Standard LRN Telegram	2 blink green  3 blink green  2 blink green
<i>Double Short Press</i> (Each Press <1s Pause in between <1s)	<b>Start Function Test</b> Measure and report sensor status every 3 seconds  Indicate acceleration detection status (above threshold or not) via LED  Function test ends after 2 minutes or upon any button press	Start: 2 blink red-green  Measurement with acceleration not above threshold: 1 blink red  Measurement with acceleration above threshold: 1 blink green

STM 550 / EMSI – ENOCEAN MULTISENSOR FOR IOT APPLICATIONS

<i>Triple Short Press</i> (Each Press <1s Pauses in between <1s)	<b>Transition to High Security Mode and Send Security LRN Telegram</b> <i>If in Standard Mode:</i> Enter High Security Mode Send Security LRN Telegram  <i>If in High Security Mode:</i> Stay in High Security Mode Send Security LRN Telegram	3 blink green  3 blink green
<i>Quad Short Press</i> (Each Press <1s Pauses in between <1s)	<b>Transition to Standard Mode and Send LRN Telegram</b> <i>If in Standard Mode:</i> Stay in Standard Mode Send LRN Telegram  <i>If in High Security Mode:</i> Enter Standard Mode Send LRN Telegram	2 blink green  2 blink green
<i>Single Long Press</i> (Press 3s ... 5s)	<b>Transition to Sleep Mode</b> <i>If in Sleep Mode:</i> Stay in Sleep Mode  <i>If in any other mode:</i> Enter Sleep Mode	3 blink red  3 blink red
<i>Double Long Press</i> (Each Press 3s ... 5s Pause in between <1s)	<b>Toggle LED Indication</b> <i>If LED Indication is Enabled:</i> Disable LED Indication  <i>If LED Indication is Disabled:</i> Enable LED Indication	4 blink red  4 blink green
<i>Single Very Long Press</i> (Press >= 7s)	<b>Factory Reset</b> Reset device configuration (to default configuration values)	Success: 5 blink green Insufficient energy: 5 blink red

**Table 3 – STM 550 user interface actions**

**4.2.1 LRN button timing**

To guide users on the expected duration of long and very long button presses, STM 550 will indicate the timing of a long button press by one short red blink and the timing of a very long button press by two red blinks as shown in Table 4.

<b>Type of press</b>	<b>Duration</b>	<b>LED Timing Indication</b>
Short	< 3 seconds	None
Long	> 3 seconds	One short red blink after 3 seconds
Very long	> 7 seconds	One short red blink after 3 seconds Two short red blinks after 7 seconds

**Table 4 – LED timing indication**

STM 550 / EMSI – ENOCEAN MULTISENSOR FOR IOT APPLICATIONS

---

### 4.3 Backup battery

STM 550 provides a backup battery interface to mount a CR1632 battery for cases with insufficient ambient light. The backup battery has to be installed with the negative pole pointing upwards (i.e. towards the side of the solar cell). Check the '+' and '-' polarity markings on the housing for correct battery orientation as shown in Figure 16 below.

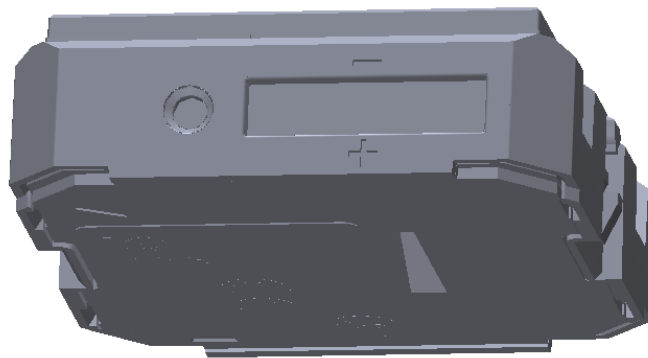

**Figure 16 – Backup battery slot with polarity markings**

EnOcean recommends Renata CR1632 due to its low self-discharge and high capacity. Gloves should be used when installing a backup battery to avoid contamination of the isolation area between the contacts that could lead to a higher self-discharge.

The backup battery can be removed (ejected) by using a small, non-conductive item (e.g. wooden toothpick) to push the battery out via the battery ejector slot on the back side of STM 550 as shown in chapter 2.2.

#### 4.3.1 Safety remarks

Please familiarize yourself with the following safety remarks before using a backup battery:



Do not insert any tools into the battery slot or the battery ejection slot. Doing so could create a short circuit or damage the PCB resulting in permanent damage.



CAUTION: Risk of damage or explosion if a battery of incorrect type is used.



This product can contain a coin/button cell battery. If the coin/button cell battery is swallowed, it can cause severe internal burns in just 2 hours and can lead to death.



Keep new and used batteries away from children.

STM 550 / EMSI – ENOCEAN MULTISENSOR FOR IOT APPLICATIONS

**4.4 Product label**

Each STM 550 module contains a product label with a commissioning QR code. Figure 17 shows the structure of the STM 550, STM 550U and STM 550J product labels. Note the commissioning QR code (described in chapter 4.4.1) on the bottom left side.

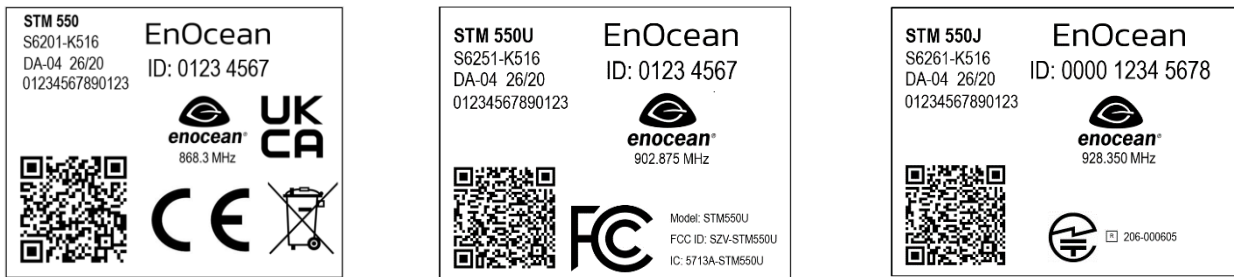

**Figure 17 – STM 550, STM 550U and STM 550J product label structure**

**4.4.1 Commissioning QR Code**

The STM 550 product label shown in Figure 17 contains a QR code which encodes device parameters according to the ANSI/MH10.8.2-2013 industry standard for product identification. Table 5 shows the identification fields used by the QR code of STM 550.

Identifier	Length of data (excluding identifier)	Value
30S	8 characters	EURID (hex)
1P	12 characters	EnOcean Alliance Product ID (hex)
13Z	32 characters	Security Key (hex)
31Z	8 characters	NFC PIN Code (hex)
30P	Up to 10 characters	Ordering Code (string)
2P	4 characters	Step Code - Revision (string)
S	14 characters	Serial Number (decimal)

**Table 5 – QR code format**

The identification string encoded in the example in Figure 17 has the following content:

30S00000412F30E+1P000B0000004C+13ZF9714BC5E8345CA72DFC78DB7514624F+31Z0000E500+30PS6201-K516+2PDC10+S01577501000097

Field	Value
EURID (30S)	00000412F30E
EnOcean Alliance Product ID (1P)	000B0000004C
Security Key (13Z)	F9714BC5E8345CA72DFC78DB7514624F
NFC PIN Code (31Z)	0000E500
Ordering Code (30P)	S6201-K516
Step Code - Revision (2P)	DC10
Serial Number (S)	01577501000097

**Table 6 – QR code content**

STM 550 / EMSI – ENOCEAN MULTISENSOR FOR IOT APPLICATIONS

## 5 Radio communication

STM 550 devices communicate using radio telegrams encoded according to the EnOcean Equipment Profile (EEP) specification and the EnOcean Alliance Signal Telegram specification on a radio link according to the EnOcean Alliance Radio Protocol (ERP). Please refer to Appendix 0 for a description of the EnOcean radio protocol.

STM 550 uses the ERP1 standard (ISO 14543-3-10) while STM 550U and STM 550J use the ERP2 (ISO 14543-3-11) standard.

### 5.1 Supported EnOcean Equipment Profiles (EEP)

STM 550 supports a wide range of EEP suitable for different use cases. Table 7 below lists the supported EEP.

Profile	Type	Reported Parameters	Parameter Range	Size / Resolution
D5-00-01	1BS	Magnet Contact	Open / Closed	1 Bit
A5-02-05	4BS	Temperature	0°C ... 40°C	8 bit
A5-04-01	4BS	Temperature	0°C ... 40°C	8 Bit
		Humidity	0% ... 100% r.h.	8 Bit
A5-04-03	4BS	Temperature	-20°C ... 60°C	10 Bit
		Humidity	0% ... 100% r.h.	8 Bit
A5-06-02	4BS	Light Sensor	0 lx ... 1020 lx	8 Bit
A5-06-03	4BS	Light Sensor	0 lx ... 1000 lx	10 Bit
A5-14-05	4BS	Vibration Detector	Above / Below threshold	1 Bit
D2-14-40	VLD (9 Byte)	Temperature	-40°C ... 60°C	10 Bit
		Humidity	0% ... 100% r.h.	8 Bit
		Illumination	0 ... 100000 lx	17 Bit
		Acceleration x-axis	+/- 2.5g	10 Bit
		Acceleration y-axis	+/- 2.5g	10 Bit
		Acceleration z-axis	+/- 2.5g	10 Bit
		Acceleration Status	Above / Below threshold	2 Bit
D2-14-41 (Default)	VLD (9 Byte)	Temperature	-40°C ... 60°C	10 Bit
		Humidity	0% ... 100% r.h.	8 Bit
		Illumination	0 ... 100000 lx	17 Bit
		Acceleration x-axis	+/- 2.5g	10 Bit
		Acceleration y-axis	+/- 2.5g	10 Bit
		Acceleration z-axis	+/- 2.5g	10 Bit
		Acceleration Status	Above / Below threshold	2 Bit
		Magnet Contact	Open / Closed	1 Bit

**Table 7 – Supported EEP**



STM 550 / EMSI – ENOCEAN MULTISENSOR FOR IOT APPLICATIONS

**5.1.1 Default EEP**

The EEP used by STM 550 to report its sensor status can be selected using EEP register of the NFC configuration interface described in chapter 8.

The default EEP used by STM 550 is D2-14-41 (VLD with 9 byte payload).

**5.2 Supported SIGNAL telegram types**

SIGNAL telegrams are used to report device conditions such as energy status or backup battery status separate from the data reporting in EEP. Table 8 below lists the SIGNAL types supported by STM 550 together with their reported data.

MID	Content	Data
0x06	Energy status (remaining energy)	1 byte integer value (expressing %) Valid values: 0 ... 100
0x0D	Energy delivery of the harvester	1 byte Enumeration Valid values: 0x00 (best) ... 0x04 (worst)
0x0E	Radio disabled	Transmitted upon entering standby mode No additional data
0x10	Backup battery status	1 byte integer value (expressing %) Valid values: 0 ... 100

**Table 8 – Supported SIGNAL types**

**5.2.1 Enabled SIGNAL telegram types**

The reporting of the supported SIGNAL types by STM 550 can be enabled and disabled using the SIGNAL register of the NFC interface described in chapter 8.

By default, SIGNAL 0x06 (Energy Status) and SIGNAL 0x0E (Radio Disabled) are enabled while SIGNAL 0x0D (Energy Delivery of Harvester) and 0x10 (Backup Battery Status) are disabled.

**5.2.2 SIGNAL telegram transmission rate**

STM 550 will transmit each of the enabled SIGNAL telegram types once for every *n* EEP (data) telegrams with *n* being a configurable parameter that can be set via the NFC interface as described in chapter 8.

The default setting is that each enabled SIGNAL telegram type will be transmitted once every 32 EEP (data) telegrams, i.e. STM 550 will report the enabled SIGNAL types approximately once every hour.

## 6 Security

STM 550 implements the security handling functions as specified in the EnOcean security specification: <https://www.enocean-alliance.org/sec/>.

Please refer to Appendix B for a description of EnOcean security mechanisms.

### 6.1 STM 550 security implementation

STM 550 supports both standard and high security modes as defined by EnOcean Alliance. The security mode can be selected both via the LRN button and via the NFC interface.

For high security mode, the default security level format (SLF) is set to use a 4 byte sequence counter to generate a 4 byte signature.

For backwards compatibility with legacy systems, it is possible to select via NFC a legacy mode using a 3 byte sequence counter to generate a 3 byte signature.

STM 550 will use secure chained telegrams (SEC\_CDM) if high security mode is used and the telegram payload (including rolling code and CMAC) exceeds 14 byte.

## 7 Commissioning

Commissioning is the process by which STM 550 is learned into a receiver (actuator, controller, gateway, etc.).

The following two tasks are required in this process:

- **Device identification**  
The receiver needs to know how to uniquely identify this specific STM 550 device. This is achieved by using a unique 48 Bit ID (Source Address) for each STM 550 device.
- **Security parameter exchange**  
The receiver needs to be able to authenticate radio telegrams from STM 550 in order to ensure that they originate from this specific device and have not been modified. This is achieved by exchanging a 128 Bit random security key used by STM 550 to authenticate its radio telegrams.

STM 550 provides the following options for these tasks:

- **Radio-based commissioning**  
STM 550 can communicate its parameters via special radio telegrams (teach-in telegrams) to the intended receiver. Transmission of such telegrams can be triggered by using the LRN button.
- **QR code commissioning**  
Each STM 550 device contains an optically readable Quick Response (QR) Code which identifies its ID and its security key. This QR code can be read by a suitable commissioning tool (e.g. smartphone) which is already part of the network into which STM 550 will be commissioned. The commissioning tool then communicates these parameters to the intended receiver of STM 550 radio telegrams.
- **NFC commissioning**  
Each STM 550 device contains an NFC interface allowing to read device parameters and to configure a user-defined security key.

## 7.1 Radio-based commissioning

Radio-based commissioning is used to associate STM 550 with other devices by sending a dedicated radio telegram (a so-called commissioning telegram).

To do so, STM 550 can transmit a dedicated teach-in telegram identifying its relevant parameters as discussed in chapter 5.1. Transmission of the teach-in telegram is triggered by pressing the LRN button or via the NFC interface described in chapter chapter 8.

Radio-based commissioning mode is intended for applications where NFC commissioning cannot be used. Radio-based commissioning can be disabled via NFC if the device is operating in high security mode to prevent transmission of the security key over the air.

## 7.2 QR code commissioning

QR code-based commissioning reads the required parameters from a dedicated QR code in the product label as described in chapter 4.4.1.

From this QR code, it is possible to extract the device address (00000412F30E in the example) and the security key (F9714BC5E8345CA72DFC78DB7514624F in the example) which can then be used to commission STM 550 into a receiver and to decrypt and authenticate STM 550 data telegrams as described in chapter 6.

## 7.3 Commissioning via NFC interface

STM 550 implements NFC Forum Type 2 Tag functionality as specified in the ISO/IEC 14443 Part 2 and 3 standards.

The NFC interface of STM 550 described in chapter 8 allows reading the device address and configuring the security key so that a receiver can identify and authenticate telegrams originating from STM 550.

STM 550 / EMSI – ENOCEAN MULTISENSOR FOR IOT APPLICATIONS

---

## 8 NFC interface

STM 550 implements an NFC configuration interface that can be used to access (read and write) the STM 550 configuration memory and thereby configure the device as described in the following chapters.

NFC communication distance is for security reasons set to require direct contact between the NFC reader and the STM 550 device.



Note that STM 550 temporarily stops operation to ensure configuration data integrity while the NFC reader is connected to the NFC interface of STM 550. STM 550 will automatically resume operation approximately 5 seconds after the NFC reader has been disconnected from the NFC interface of STM 550.



Care must be taken not to configure unsupported values as product behavior is undefined in that case.

### 8.1 NFC interface parameters

The NFC interface of STM 550 uses NFC Forum Type 2 Tag functionality as specified in the ISO/IEC 14443 Part 2 and 3 standards. For a detailed description about the NFC functionality, please refer to the ISO/IEC 14443 standard.

### 8.2 NFC access protection

Protected data access is only possible after unlocking the configuration memory with the correct 32-bit PIN code. By default, the protected area is locked and the default pin code for unlocking access is `0x0000E500`.

The default pin code shall be changed to a user-defined value as part of the installation process. This can be done by unlocking the NFC interface with the old PIN code and then writing the new PIN code to page `0x4B`.

### 8.3 Using the NFC interface

Using the NFC interface requires the following:

- NFC reader  
This can be either a USB NFC reader connected to a PC or a suitable smartphone with NFC functionality
- NFC SW with read, write, PIN lock, PIN unlock and PIN change functionality  
This can be either a PC application or an Android / iOS app

These options are described in more detail below.

#### 8.3.1 PC with dedicated NFC reader

For PC-based applications, EnOcean provides a dedicated PC application called EnOcean NFC configurator which works in conjunction with the TWN4 Multitech 2 HF NFC Reader.

EnOcean NFC Configurator can be obtained available from the EnOcean homepage:  
<https://www.enocean.com/en/product/enocean-nfc-configurator/>

The TWN4 Multitech 2 HF NFC Reader is available from Elatec RFID Systems ([sales-rfid@elatec.com](mailto:sales-rfid@elatec.com)) using order code T4BT-FB2BEL2-SIMPL. It is shown in Figure 18 below.



**Figure 18 – Elatec TWN4 MultiTech Desktop NFC Reader**

#### 8.3.2 Android or iOS smartphone with NFC

NFC functionality is available in certain Android (e.g. Samsung Galaxy or newer) and iOS (iPhone7 or newer, firmware version 13 or newer) smartphones.

EnOcean provides the configuration app “EnOcean Tool” for these devices which can be downloaded directly from the respective app store.

At the time of writing, the tool was available from the Google Play Store using this link:  
<https://play.google.com/store/apps/details?id=de.enocean.easytool&hl=en>

Likewise, the tool was available from the Apple Store using this link:  
<https://apps.apple.com/de/app/enocean-tool/id1497283202>

## 9 Mechanical interface

### 9.1 STM 550

STM 550 implements the mechanical interface of the PTM 21x module which is described in more detail in this chapter. All dimensions and tolerances given are in millimetres unless otherwise noted.

#### 9.1.1 Top view

Figure 19 below shows the STM 550 module seen from the top. The cut view along the A-A line is shown in chapter 9.1.3.

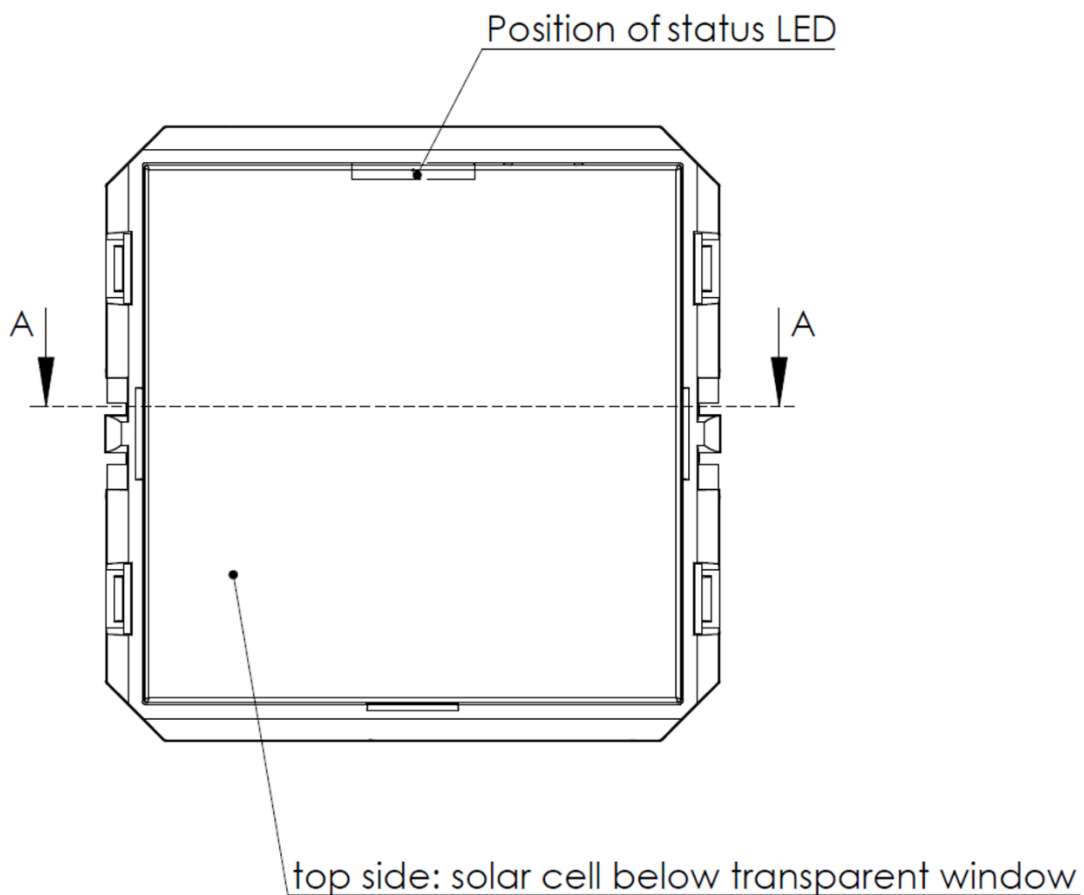
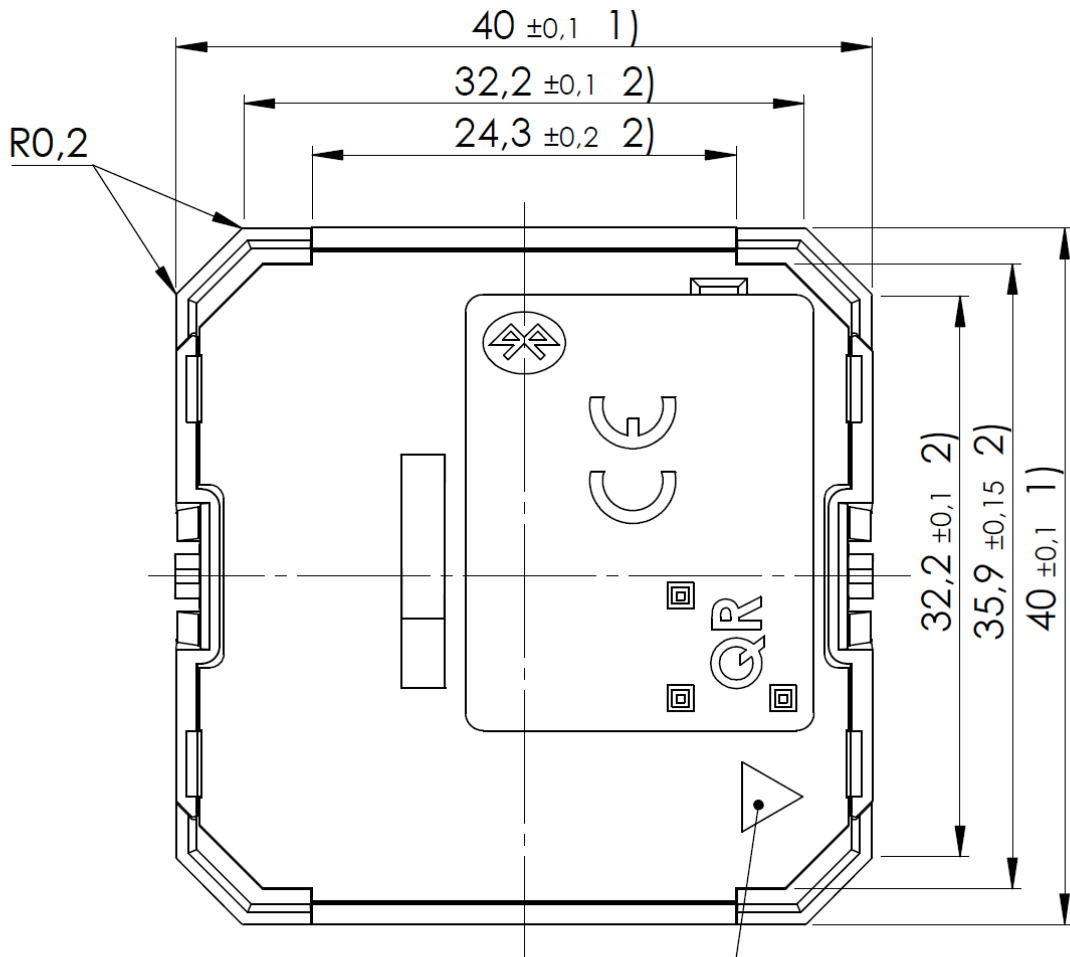

**Figure 19 – Top view of STM 550 module**

STM 550 / EMSI – ENOCEAN MULTISENSOR FOR IOT APPLICATIONS

**9.1.2 Bottom view**

Figure 20 below shows the STM 550 module seen from the bottom.



marking of position of magnet contact

**Figure 20 – Bottom view of STM 550 module**



STM 550 / EMSI – ENOCEAN MULTISENSOR FOR IOT APPLICATIONS

9.1.3 Cut view (A-A)

Figure 21 below shows a cut along the A-A line of Figure 19 and highlights the area of the mounting structure (B region) in more detail.

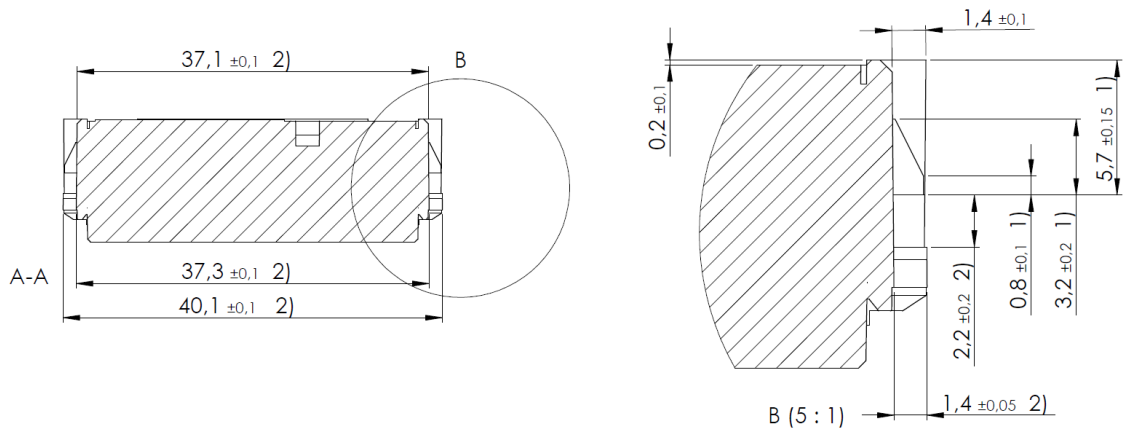

Figure 21 – Cut view (A-A) of STM 550 module

9.1.4 Front view

Figure 22 below shows the STM 550 module seen from the front.

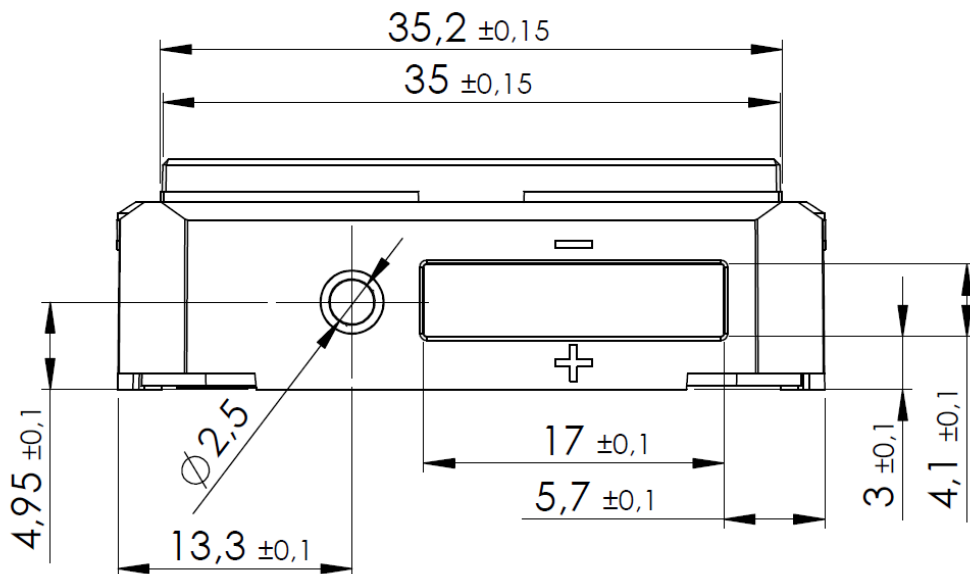
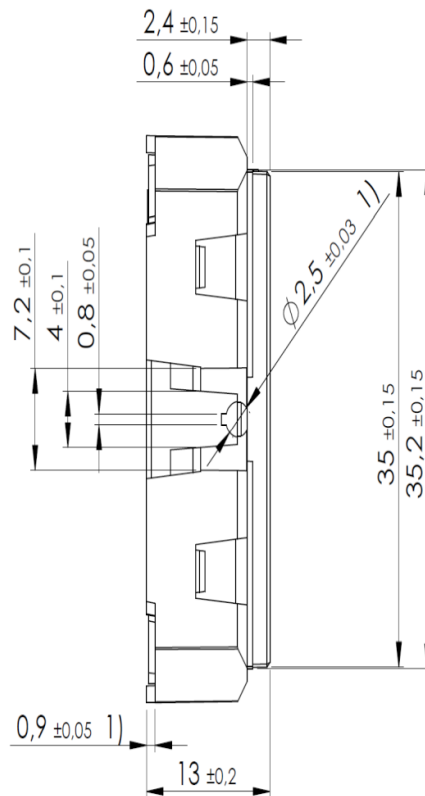

Figure 22 – Front view of STM 550 module

STM 550 / EMSI – ENOCEAN MULTISENSOR FOR IOT APPLICATIONS

**9.1.5 Side view**

Figure 23 below shows the STM 550 module seen from the side.



**Figure 23 – Side view of STM 550 module**

STM 550 / EMSI – ENOCEAN MULTISENSOR FOR IOT APPLICATIONS

9.2 EMSI

EMSI integrates the STM 550 module into a housing. Figure 24 below shows the mechanical interface of EMSI.

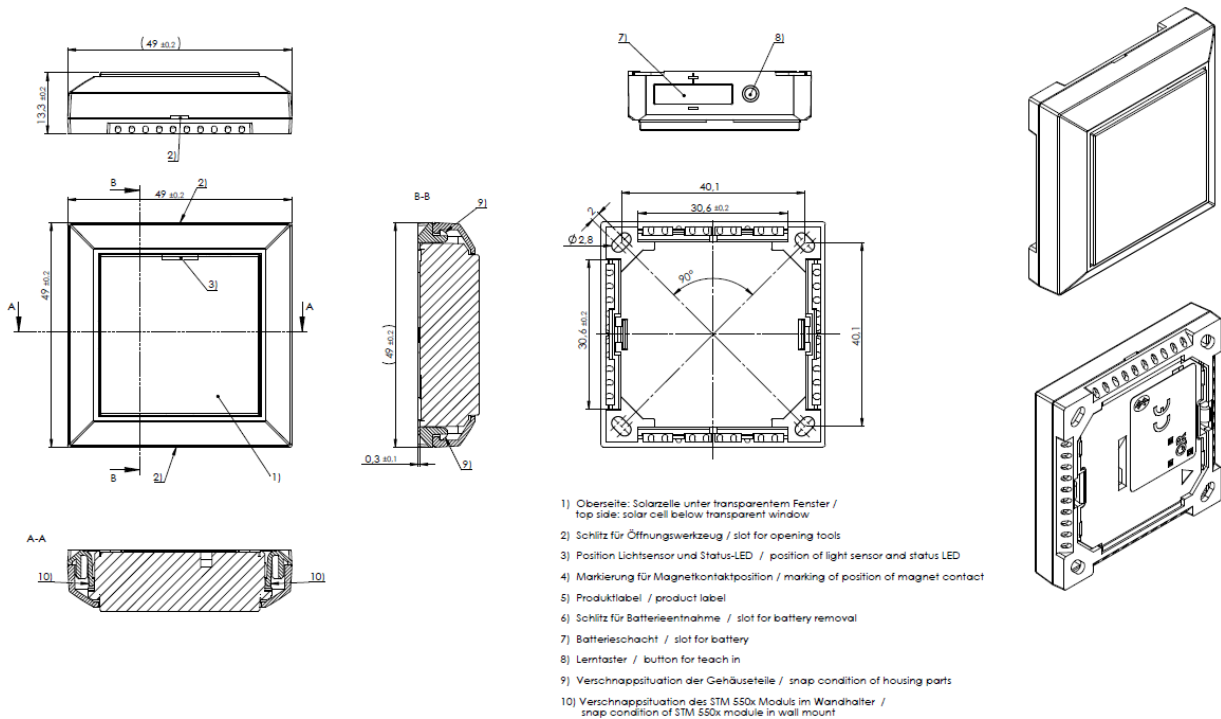

Figure 24 – Mechanical interface of EMSI

EMSI can be attached to a variety of surfaces using the provided adhesive pad. Figure 25 below shows the dimensions of this pad.

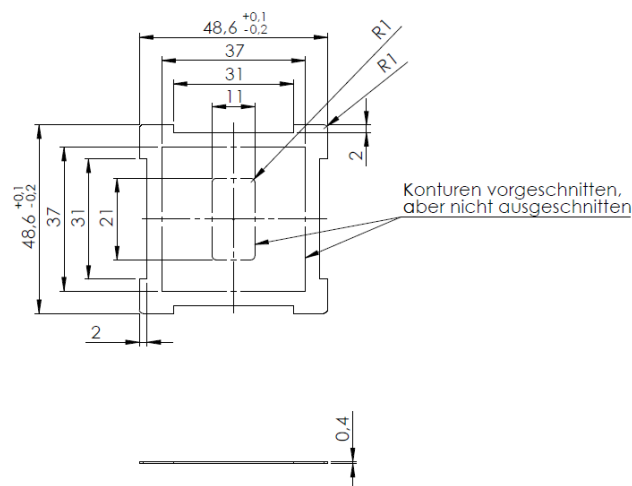

Figure 25 – Adhesive pad

## 10 Installation recommendations

### 10.1 Setup instructions

Before installing STM 550 into its intended location, a sufficient initial charge should be provided to STM 550 and the correct operation of STM 550 should be verified.

To do so, follow these steps:

1. Expose STM 550 to bright light (near a window or a bright light source) for 5 minutes to provide an initial charge
2. Press the LRN button once so that STM 550 will start operation
3. Check that STM 550 transmits radio telegrams at the configured update interval (by default once every 2 minutes). The LED will blink every time a telegram is transmitted (unless this has been disabled via NFC).
4. Maximize the amount of available light for energy harvesting by selecting a suitable installation position and device orientation (orient the solar cell towards the primary light source if possible).
5. Note that it will not always be possible to install STM 550 in the location with the highest ambient light level as this might impact measurement accuracy. For instance, an installation location with exposure to direct sunlight has to be avoided for temperature or acceleration measurements.
6. Verify the available light level at the intended installation location by executing an Illumination Test as described in chapter 2.3.5.
7. Consider disabling the measurement of non-required parameters (especially acceleration) to conserve energy for cases where the available light is not optimal.
8. Use a suitable receiver (for instance, a PC running DolphinView telegram analysis SW in conjunction with a USB 300 / USB 500U / USB 500J EnOcean radio gateway) to receive STM 550 data telegrams and verify the intended functionality.

After those steps, STM 550 can be permanently installed in the selected installation location and is ready for operation.

STM 550 / EMSI – ENOCEAN MULTISENSOR FOR IOT APPLICATIONS

---

## 10.2 Installation location

Before selecting the installation location for STM 550, please consider the following general guidance:

- STM 550 is designed for indoor use only
- STM 550 should be operated within a temperature range of  $-5^{\circ}\text{C}$  ...  $+45^{\circ}\text{C}$   
Avoid excessive heat-up due to direct exposure to sun light
- STM 550 should be used within a humidity range of 0% ... 90% r.h.  
Avoid environments with condensation (for instance the area around entry doors to air-conditioned rooms)
- STM 550 should not be used on fast moving or strongly vibrating parts.  
If used as a door sensor, STM 550 should be attached to the stationary door frame
- STM 550 should not be exposed to direct sunlight outdoors to avoid overheating of the device and overexposure of the solar cell which might permanently damage the device

Additionally, application-specific guidance (for specific use cases) is provided in subsequent chapters.

## 10.3 Mounting options (EMSI only)

EMSI combines the STM 550 module with a wall mount and a design frame into a ready to use product. The wall mount can be attached to most surfaces either by screws (using the four screw holes) or via an adhesive pad. Mounting via an adhesive pad is the recommended approach.

EMSI includes a suitable two-zone adhesive pad as shown in below. Use of the outer adhesive zone (marked blue) is sufficient for most applications and enables easy removal of EMSI from the mounting surface. The inner adhesive zone (marked green) can be additionally used if firm attachment to the mounting surface is desired.

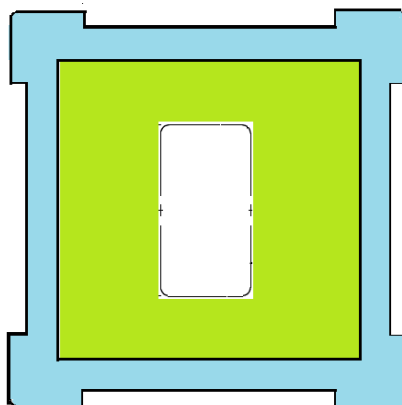

**Figure 26 – Adhesive zones**

## STM 550 / EMSI – ENOCEAN MULTISENSOR FOR IOT APPLICATIONS

## 10.4 Temperature and humidity sensor

The dedicated temperature and humidity sensor integrated into STM 550 accurately measures and reports temperature and humidity present at its surface. To achieve the best possible accuracy, it is important to consider the following points:

- **Installation height**  
The sensor should be installed at a height that is representative for the use case. For the case of an office, the sensor should be mounted at desk level.
- **Sun light or heat exposure**  
The sensor should be mounted such that it is not directly exposed to sunlight or heat (e.g. close to a radiator)
- **Disturbances**  
The sensor should be mounted such that the influence from disturbances such as the air stream from air condition units is minimized. Consider also the possible temperature gradient between wall and room when mounting the sensor directly onto a wall.
- **Airflow**  
The sensor should be mounted such that the airflow from the target measurement area towards the air inlets is maximized. This will ensure the lowest possible response time of the sensor.  
Avoid mounting the sensor in niches or slots with little air flow. The sensor should be mounted such that the airflow from the target measurement area towards the air inlets is maximized. This will ensure the lowest possible response time of the sensor.  
Avoid mounting the sensor in niches or slots with little air flow.  
When designing your own housing around the STM 550 module, consider the location of the ventilation slots (there are four of them in total) as shown in Figure 27. Housing design should maximize the airflow towards these slots focusing especially on the two slots nearest to the sensor which are marked with a green dot.

Figure 27 below shows the location of the temperature and relative humidity (TRH) sensor and of the ventilation slots.

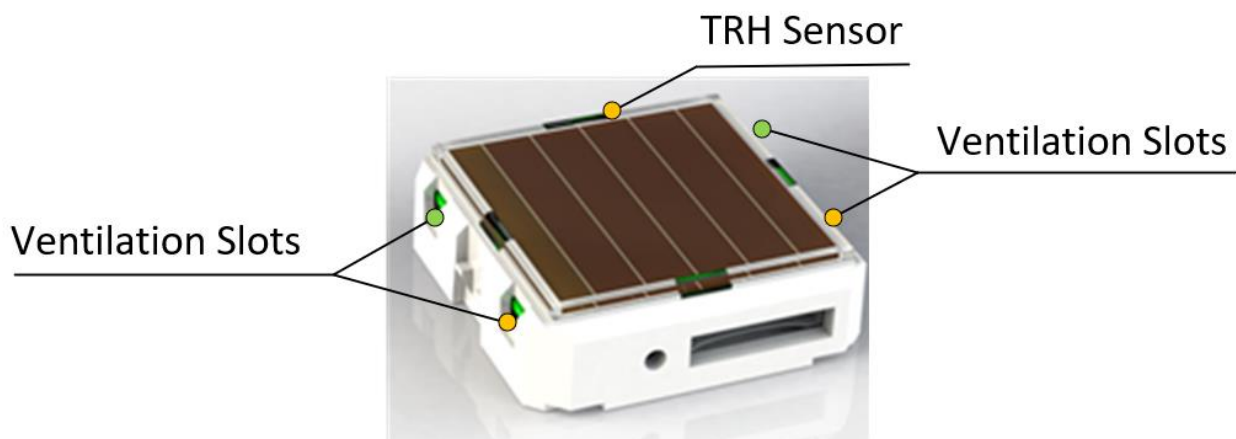

**Figure 27 – Location of temperature / humidity sensor and ventilation slots**

## 10.5 Acceleration sensor

Acceleration sensors measure the acceleration vector in all three dimensions  $\{x; y; z\}$ . This sensor can be used both to determine the device orientation (relative to the earth gravity vector) and the device acceleration (e.g. if a device is moved or shaken). Both cases will be discussed below.

### 10.5.1 Device orientation use cases

If an object is at rest or continuously moving at the same speed, then the magnitude of the vector will be 1g (i.e. the magnitude of the measured acceleration vector will be equivalent to the magnitude of the earth gravity vector at the location of the device which will be approximately 1g).

Measuring the magnitude in all three dimensions allows determining the orientation of an object relative to the earth gravity as shown in Figure 28 below. This illustration assumes that STM 550 is placed flat onto a surface parallel to the earth surface (e.g. a table).

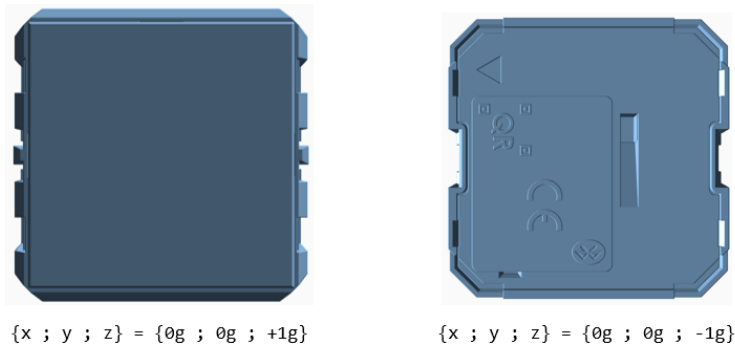

**Figure 28 – Acceleration vector based on device orientation**

Note that it is not possible to distinguish cases where STM 550 is rotated but its orientation relative to the direction of earth gravity remains the same. This is shown in Figure 29 below for the case of device rotation across the earth gravity vector axis.

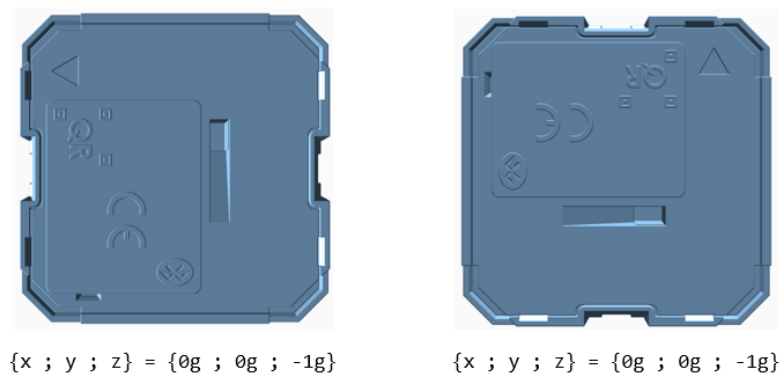

**Figure 29 – Device rotation across earth gravity vector axis**

STM 550 / EMSI – ENOCEAN MULTISENSOR FOR IOT APPLICATIONS

---

Figure 30 below illustrates this issue in a practical use case:

- The position of the window in the left case (window tilt) could be detected if STM 550 is attached to the window part that is tilted since the orientation of STM 550 relative to the gravity vector would change
- The position of the window in the right case (window open / rotation) could not be detected if STM 550 is attached to the window part that is rotated since the orientation of STM 550 relative to the gravity vector would remain the same. STM 550 would however report that the window was moved due to the resulting acceleration and deceleration.

The surface towards which STM 550 is attached should therefore be chosen to maximize orientation changes relative to the gravity vector.

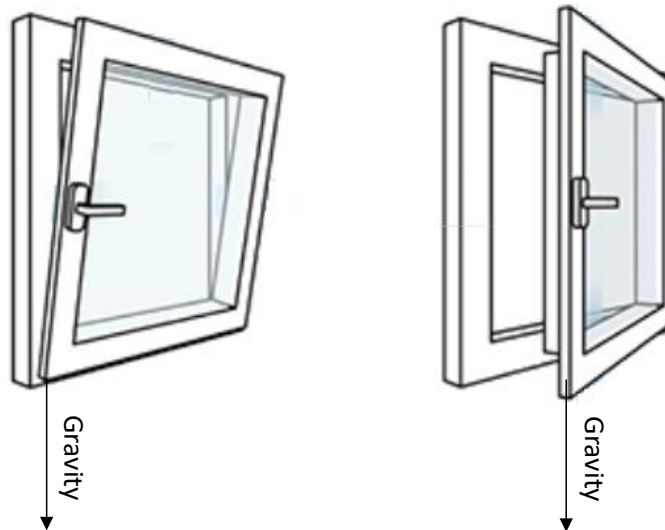

**Figure 30 – Tilt versus gravity vector**



## STM 550 / EMSI – ENOCEAN MULTISENSOR FOR IOT APPLICATIONS

### 10.5.2 Device acceleration use cases

If an object vibrates or is moved after being, then the acceleration vector measured by the acceleration sensor will change. Figure 31 below illustrates this.

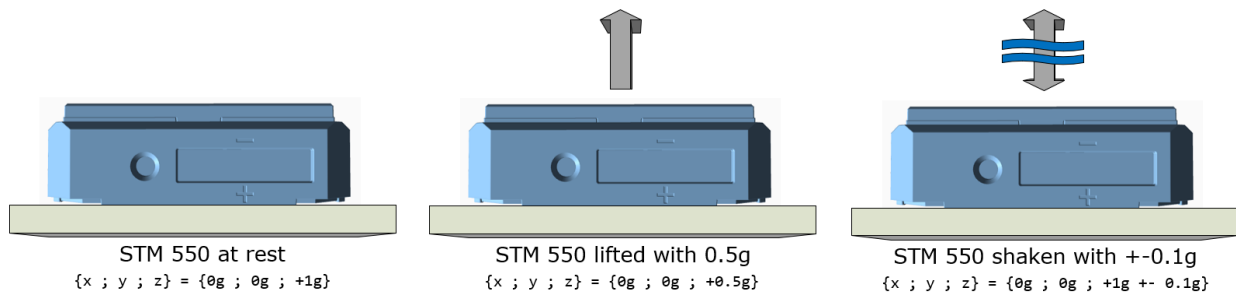

**Figure 31 – Acceleration vector changes based on motion or vibration**

This principle can be used for two major use cases:

- The approximate location of an object can be tracked based on the strength of the received periodic data telegrams. Movement of the object (e.g. from one room to another) can be detected based on the reported acceleration vector change.
- The utilization of an object (a machine that is running, a chair that is occupied, ...) can be tracked based on the characteristic vibrations associated with this utilization.

In both cases, STM 550 should be attached to the object for which location or utilization shall be monitored. The following chapter gives general guidelines how to do so.

### 10.5.3 Installation suggestions

The following points should be considered to maximize the reliability of acceleration measurement:

- STM 550 should be firmly attached to the asset without any damping to ensure that any vibration of the asset will be properly propagated to STM 550
- STM 550 should be attached to the asset at the location where the vibration is maximized. For instance, when tracking the utilization of office chairs, the highest acceleration is typically observed at the back rest.
- The acceleration threshold for wake-on-acceleration should be selected such that utilization / motion is reliably detected without false triggers due to spurious vibration (e.g. people walking by). Should the default sensitivity be insufficient even at the lowest threshold then the sampling rate should be increased
- Exposure to heat or direct sunlight should be minimized to comply with the required operation conditions and to minimize mechanical expansion of the device.

Use function test mode as described in Chapter 2.3 to verify correct installation.

STM 550 / EMSI – ENOCEAN MULTISENSOR FOR IOT APPLICATIONS

---

## 10.6 Light level measurement

Light level (or illuminance) is the amount of light measured in a plane surface. STM 550 measures the ambient light level via the solar cell as this provides a plane surface with a large active area.

Note that for non-uniform lighting conditions, the measured light level is an average value depending on the lighting conditions across the measurement surface which strongly depends on the shape and the orientation of this surface. Devices using spherical surface lenses to capture a wider aperture might report different values from plane surface sensors.

Note also that the solar cell does not apply a spectral response curve close to the human eye's perception of ambient light to the received illumination. For these reasons, calibration at the receiver is suggested to obtain best results for the given lighting situation.

## 10.7 Magnet contact sensing

If STM 550 is used to detect the presence of a magnet using its magnet contact sensor (e.g. for door or window monitoring), then the magnet has to be in close proximity to the STM 550 magnet contact sensor for the case where a "Magnet Present" (or "Closed") condition shall be detected. Refer to Chapter 2.2 for the location of the sensor.

Attach the magnet to the intended surface (e.g. door or window) such that the centre of the large side of the magnet is oriented towards the location of the magnet contact sensor in STM 550 and that the distance between magnet and STM 550 housing is less than 1 cm for the "Magnet Present" condition. Verify that the state (e.g. door open or closed) is reported as expected.



Note that the magnet contact sensor uses a Reed (mechanic) contact to detect the proximity of the magnet. Exposing STM 550 to strong vibration might cause the magnet contact sensor to temporarily close also in absence of a magnet.

## 10.8 Energy harvesting

STM 550 is powered by ambient light using its integrated solar cell. For best performance it is therefore essential to maximize the amount of light available for harvesting.

Harvestable light will typically be either natural light (daylight coming in through windows etc) or artificial light (direct or reflected light from indoor luminaires). If natural light is available (e.g. from a window) then the solar cell of STM 550 should be oriented as much as possible towards that. The amount of available light can be determined by executing an illumination test as described in chapter 2.3.5.

STM 550 is designed to operate self-supplied with its standard parameters based on 200 lux of illumination at its solar cell for at least 6 hours per day. STM 550 can operate for 4 days without available energy after being exposed to 200 lux for 2 days.

Lower levels of available light can be addressed by configuring a lower reporting rate via NFC as discussed in chapter 2.4. If the available light is insufficient, then STM 550 offers the option for a CR1632 backup battery as described in chapter 4.3.

## 10.9 NFC configuration

STM 550 can be flexibly configured for a wide range of application scenarios using the NFC configuration interface as described in chapter 8.



Updating the device configuration via the NFC interface requires that STM 550 has sufficient energy to read and process the new parameters.

It is therefore recommended to provide an initial charge to STM 550 by placing it under bright light for 5 minutes before starting the configuration process.

Before making any configuration changes, be sure to familiarize yourself with the device functionality and determine the energy constraints based on the available ambient light as discussed in chapter 2.4. Be especially careful not to configure higher update rates (low reporting intervals) before ensuring that sufficient light is available.

Should you be unsure about the current NFC configuration, then execute a factory reset as described in chapter 2.3.6 to reset all configuration registers to their default setting.

After writing the new NFC configuration, remove the device from the NFC reader (or disconnect the NFC interface) to trigger the read and update process. STM 550 will indicate the successful completion of this process by two short red blinks of the LED.

Once STM 550 has been configured to the intended parameters and correct functionality has been verified, the NFC configuration interface must be locked by changing the NFC PIN code from its default value to a different (secret) value. Make sure the new PIN code is properly noted down.

## 11 Regulatory notes

### 11.1 European Union

#### 11.1.1 Declaration of conformity

Hereby, EnOcean GmbH, declares that this radio equipment is in compliance with the essential requirements and other relevant provisions of Directive 2014/53/EU. A copy of the Declaration of Conformity can be obtained from the product webpage at [www.enocean.com](http://www.enocean.com)

#### 11.1.2 Waste treatment

##### **WEEE Directive Statement of the European Union**

The marking below indicates that this product should not be disposed with other household wastes throughout the EU. To prevent possible harm to the environment or human health from uncontrolled waste disposal, recycle it responsibly to promote the sustainable reuse of material resources.

Germany: WEEE-Reg-No.: DE 93770561

##### **BATTERY Directive**

The symbol below indicates that batteries must not be disposed of in the domestic waste as they contain substances which can be damaging to the environment and health. Please dispose of batteries in designated collection points.

Germany: UBA Reg-No.: 21008516



STM 550 / EMSI – ENOCEAN MULTISENSOR FOR IOT APPLICATIONS

11.2 FCC (United States)

11.2.1 FCC Grant Of Equipment Authorization

TCB

GRANT OF EQUIPMENT AUTHORIZATION

TCB

Certification Issued Under the Authority of the Federal Communications Commission By:

Timco Engineering, Inc. 849 NW State Road 45 Newberry, FL 32669

Date of Grant: 02/04/2021 Application Dated: 02/04/2021

EnOcean GmbH Kolpingring 18a Oberhaching, 82041 Germany

Attention: Armin Anders , Director Product Marketing

NOT TRANSFERABLE

EQUIPMENT AUTHORIZATION is hereby issued to the named GRANTEE, and is VALID ONLY for the equipment identified hereon for use under the Commission's Rules and Regulations listed below.

FCC IDENTIFIER: SZV-STM550U Name of Grantee: EnOcean GmbH Equipment Class: Part 15 Security/Remote Control Transmitter Notes: Temperature and Humidity Sensor with transmitter

Grant Notes

FCC Rule Parts 15.231

Frequency Range (MHZ) 902.875 - 902.875

Output Watts

Frequency Tolerance

Emission Designator

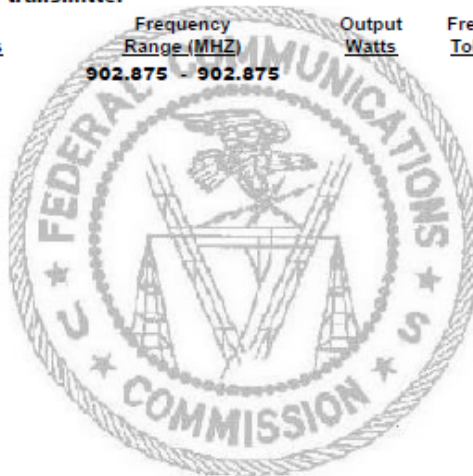

STM 550 / EMSI – ENOCEAN MULTISENSOR FOR IOT APPLICATIONS

---

**11.2.2 FCC OEM requirements**

In order to use EnOcean's FCC ID number, OEM integrating STM 550U into own products must ensure that the following conditions are met:

- The Original Equipment Manufacturer (OEM) must ensure that FCC labeling requirements are met. This includes a clearly visible label on the outside of the final product. Attaching a label to a removable portion of the final product, such as a battery cover, is not permitted.
- The label must include the following text:  
*Contains FCC ID: SZV-STM550U*  
*The enclosed device complies with Part 15 of the FCC Rules. Operation is subject to the following two conditions: (i.) this device may not cause harmful interference and (ii.) this device must accept any interference received, including interference that may cause undesired operation.*
- The FCC identifier or the unique identifier, as appropriate, must be displayed on the device.
- The user manual for the end product must also contain the text given above.

STM 550 / EMSI – ENOCEAN MULTISENSOR FOR IOT APPLICATIONS

11.3 ISED (Industry Canada)

11.3.1 ISED Technical Acceptance Certificate

**TIMCO** ENGINEERING, INC.

849 NW State Road 45  
 Newberry, Florida 32669  
[www.timcoengr.com](http://www.timcoengr.com)  
 (352) 472-5500 [CB@timcoengr.com](mailto:CB@timcoengr.com)

Job No. ▶ 0564-21

TECHNICAL ACCEPTANCE CERTIFICATE

Certification No. ▶ IC: 5713A-STM550U

Issued To ▶ EnOcean GmbH  
 Kolpingring 18A  
 Oberhaching 82041  
 Germany

Tested By ▶ VPI Laboratories, Inc.  
 Company No.: 2041B  
 313 W 12800 S., Suite 311  
 Draper, UT 84020, USA  
 801-260-4056; [jasons@vpitech.com](mailto:jasons@vpitech.com)

Type of Equipment ▶ Low Power Device (902–928 MHz)

Type of Service ▶ New Certification (Single)

Hardware Version Id Number (HVIN) ▶ STM 550U

Firmware Version Id Number (FVIN) ▶ N/A

Product Marketing Name: (PMN) ▶ STM 550U

Host Marketing (HMN) ▶ N/A

FREQUENCY RANGE	EMISSION DESIGNATIONS <small>NECESSARY BANDWIDTH &amp; EMISSION CLASSIFICATION</small>	R.F. POWER	ANTENNA INFO	SPECIFICATION, ISSUE & DATE
902.875 MHz	275KF1D	73.0 dBuV@3m	Wire, 0dB	RSS-210 Issue 10; Dec.2019

Note 1: This equipment also complies with RSS-102, Issue 5 (March 2015) and RSS-Gen, Issue 5 (March 2019)

Certification of equipment means only that the equipment has met the requirements of the above-noted specification. Licence applications, where applicable to use certified equipment, are acted on accordingly by the ISED issuing office and will depend on the existing radio environment, service and location of operation. This certificate is issued on condition that the holder complies and will continue to comply with the requirements and procedures issued by ISED. The equipment for which this certificate is issued shall not be manufactured, imported, distributed, leased, offered for sale or sold unless the equipment complies with the applicable technical specifications and procedures issued by ISED.

La certification de l'équipement signifie uniquement que l'équipement a satisfait aux exigences de la spécification susmentionnée. Les demandes de licence, le cas échéant pour utiliser un équipement certifié, sont traitées en conséquence par le bureau émetteur d'ISED et dépendront de l'environnement radio, du service et du lieu d'exploitation existants. Ce certificat est délivré à condition que le titulaire se conforme et continuera de se conformer aux exigences et procédures émises par ISED. L'équipement pour lequel ce certificat est délivré ne doit pas être fabriqué, importé, distribué, loué, mis en vente ou vendu à moins que l'équipement ne soit conforme aux spécifications et procédures techniques applicables émises par ISED.

I hereby attest that the subject equipment was tested and found in compliance with the above-noted specifications.

J'atteste par la présente que le matériel a fait l'objet d'essai et jugé conforme à la spécification ci-dessus.

ISSUED UNDER THE AUTHORITY OF MINISTER OF INDUSTRY  
 DELIVRÉ AVEC L'AUTORISATION DU MINISTRE DES INDUSTRIES

DATE: February 5, 2021

*Bruno Clavier*  
 Bruno Clavier, General Manager

Canadian Certification

### **11.3.2 ISED (Industry Canada) regulatory statement**

This device complies with Industry Canada licence-exempt RSS standard(s). Operation is subject to the following two conditions:

- (1) this device may not cause interference, and
- (2) this device must accept any interference, including interference that may cause undesired operation of the device.

Le présent appareil est conforme aux CNR d'Industrie Canada applicables aux appareils radio exempts de licence. L'exploitation est autorisée aux deux conditions suivantes :

- (1) l'appareil ne doit pas produire de brouillage, et
- (2) l'utilisateur de l'appareil doit accepter tout brouillage radioélectrique subi, même si le brouillage est susceptible d'en compromettre le fonctionnement.”



STM 550 / EMSI – ENOCEAN MULTISENSOR FOR IOT APPLICATIONS

**11.4 ARIB (Japan)**

**11.4.1 ARIB construction type conformity certificate**



Notified Body EMC Directive 2014/30/EU  
 Notified Body Directive 2014/53/EU  
 RF CAB under the Japan-EC MRA  
 FCB under the Canada-EC MRA  
 TCB under the USA-EC MRA

RF CAB ID No. 206

Designated by the German Regulator Bundesnetzagentur to act as a  
 Recognised Foreign Conformity Assessment Body in accordance with the Japan-EC MRA

**CONSTRUCTION TYPE CONFORMITY CERTIFICATE**  
 for  
**Specified Radio Equipment**

Registration No.	JU000605M
Certificate Holder	EnOcean GmbH Kolpingring 18a 82041 Oberhaching Germany
Product Category	Article 2, Paragraph 1, Item 8 (Y)
Product Designation	TCM 500J, TCM 501J, TCM 515J, STM 550J, EMSIJ, EMDCJ
Product Description	Wireless Transceiver
Software Release No.	--
Manufacturer	Katek GmbH Bahnhofstraße 108 83224 Grassau Germany

When the product is placed on the Japanese market, it must carry the Specified Radio Equipment marking as shown on the right



**R 206-000605**

The scope of evaluation relates to the submitted documents only.

This Certificate confirms that the listed product has demonstrated conformity with the relevant technical regulations defined in the attached Annex. It is only valid in conjunction with the Annex.

Unterleinleiter,  
2020-09-02

Karlheinz Kraft  
Recognised Foreign Conformity Assessment Body

EMCCcons DR. RAŠEK GmbH & Co. KG • Stoernhofer Berg 15, 91364 Unterleinleiter, Germany  
 Tel.: +49 9194 7263-888 • Fax: +49 9194 7263-889 • E-mail: emc.cert@emcc.de • Web: www.emcc.de

STM 550 / EMSI – ENOCEAN MULTISENSOR FOR IOT APPLICATIONS

## 12 Product history

Table 9 below lists major revisions and key changes of STM 550.

Product	Revision	Release	Key changes versus previous revision
STM 550	DC-15	June 2024	Product update Change from single colour to bi-colour LED Light sensor replaced by solar cell Reporting interval changed to 2 minutes
	DB-07	Mar 2021	Product update Corrected issues with EEP support and backup battery
	DB-06	Nov 2020	Product update Increase of transmission power to +10 dBm Improved supply voltage reporting
	DA-05	Jun 2020	Market release
STM 550J	DB-08	June 2024	Product update Change from single colour to bi-colour LED Light sensor replaced by solar cell Reporting interval changed to 2 minutes
	DA-04	Oct 2021	Manufacturing update (production test improvement)
	DA-03	Mar 2021	Product update Corrected issues with EEP support and backup battery
	DA-02	Aug 2020	Market release
STM 550U	DB-09	June 2024	Product update Change from single colour to bi-colour LED Light sensor replaced by solar cell Reporting interval changed to 2 minutes
	DA-05	May 2021	Market Release

**Table 9 – Product History**

## A. Introduction to EnOcean radio protocol

This chapter gives a high-level introduction to key aspects of the EnOcean radio protocol to help the understanding of STM 550 radio transmission features. Refer to the EnOcean Radio Protocol 1 (ERP1) specification and the EnOcean Radio Protocol 2 (ERP2) specification for detailed information.

Devices within the EnOcean ecosystem communicate using the EnOcean Radio Protocol (ERP). Two versions of this radio protocol are in use today – ERP version 1 (ERP1 in short) is used for 868.3 MHz radio systems in Europe while ERP version 2 (ERP2 in short) is used for 902.875 MHz radio systems in the US / Canada and 928.35 MHz radio systems in Japan.

### A.1 ERP1 telegram format

The ERP1 telegram format is shown in Figure 32 below for the case of a broadcast telegram.

RORG	DATA	SENDER EURID	STATUS	HASH
1 Byte	1 ... 14 Byte	4 Byte	1 Byte	1 Byte

**Figure 32 – ERP1 telegram format for broadcast telegrams**

An ERP1 telegram contains the following fields:

- RORG specifies the EEP or SIGNAL type used by this telegram
- DATA contains the telegram payload
- SENDER EURID specifies the address of the sender
- STATUS specifies transmission properties such as the repeater hop count
- HASH is used to verify the integrity of the telegram

It is possible to specify the intended receiver (the destination) of a telegram by prefixing the telegram content with the R-ORG 0xA6 (ADT = Addressed Data Telegram) to indicate that a destination address is present and including the DESTINATION EURID before the SENDER EURID as shown in Figure 33 below.

ADT	RORG	DATA	DESTINATION EURID	SENDER EURID	STATUS	HASH
0xA6	1 Byte	1 ... 9 Byte	4 Byte	4 Byte	1 Byte	1 Byte

**Figure 33 – ERP1 telegram format for addressed telegrams**

## A.2 ERP2 telegram format

The ERP2 radio telegram format is shown in Figure 34 below.

LENGTH	HEADER	EXT_HEADER	EXT_TYPE	DESTINATION EURID	SENDER EURID	DATA	OPTIONAL_DATA	CRC
1 Byte	1 Byte	1 Byte	1 Byte	4 Byte	3 / 4 / 6 Byte	Variable	Variable	1 Byte

**Figure 34 – ERP2 Telegram Format**

The ERP2 telegram contains the following fields:

- LENGTH specifies the total length of the ERP2 radio telegram
- HEADER specifies the EURID types and sizes, the RORG that is used (based on a selection of the most common EEP) and specifies if EXT\_HEADER is present
- EXT\_HEADER specifies the repeater count and the length of OPTIONAL\_DATA. It is an optional field that might be omitted by energy-constrained devices
- EXT\_TYPE specifies less common RORG which are not available within the HEADER field
- SENDER EURID specifies the device address of the sender
- DESTINATION EURID can be used to specify the device address of the intended recipient of a data telegram (optional)
- DATA contains the telegram data
- OPTIONAL\_DATA can be used to transmit additional data that should be treated separately from the main telegram data (optional)
- CRC is used to verify the integrity of the telegram

## A.3 Subtelegrams

EnOcean radio systems use the concept of redundant subtelegrams in order to increase the communication reliability. In addition to using redundant transmissions, first and second level repeaters can be used to increase communication distance.

Within this scheme, telegrams are transmitted redundantly with random (but small) delays between them. The total number of redundant subtelegrams can be either two or three. Certain telegram types (e.g. those used in very limited energy scenarios such as SMART\_ACK) do not support redundant transmission, i.e. they are transmitted only once.

If a telegram is transmitted redundantly as set of two or three subtelegrams then the first subtelegram is sent immediately upon receiving and processing the ESP3 command for telegram transmission.

The timing offset between this first subtelegram and the remaining (second or third) subtelegrams is random within pre-defined time intervals.

STM 550 / EMSI – ENOCEAN MULTISENSOR FOR IOT APPLICATIONS

**A.3.1 Subtelegram timing**

EnOcean Radio Protocol 1 (ERP1) and EnOcean Radio Protocol 2 (ERP2) uses a repeater-level dependent time slot mechanism for the subtelegram timing during transmission.

The sender of a radio telegram will transmit the first telegram immediately upon receiving the request for transmission. After that, the time offset (interval) between the first subtelegram and the second subtelegram is a random value between 1 ms and 9 ms. Likewise, the time offset (interval) between the first subtelegram and the third subtelegram is a random value between 20 ms and 39 ms.

For the first-level repeater (which received the telegram from the sender), the time offset (interval) between the reception of the telegram and the transmission of the first subtelegram is a random value between 10 ms and 19 ms. Likewise, the time offset (interval) between the reception of the telegram and the second subtelegram is a random value between 20 ms and 29 ms.

For the second-level repeater (which received the telegram from the first-level repeater), the time offset (interval) between the reception of the telegram and the transmission of the first subtelegram is a random value between 0 ms and 9 ms. Likewise, the time offset (interval) between the reception of the telegram and the second subtelegram is a random value between 20 ms and 29 ms.

Both first and second level repeaters do not transmit a third subtelegram. The standard subtelegram timing is summarized in Table 10 below.

Repeater Level	Time Offset [ms] First Subtelegram	Time Offset [ms] Second Subtelegram	Time Offset [ms] Third Subtelegram
0 (Original Telegram)	0	1 ... 9	20 ... 39
1 (Repeated for the first time)	10 ... 19	20 ... 29	No 3rd Subtelegram
2 (Repeated for the second time)	0 ... 9	20 ... 29	No 3rd Subtelegram

**Table 10 – Standard subtelegram timing**

Certain countries have regulatory limitations for the total duration of a radio transmission in certain frequency bands including those used by EnOcean products. For these cases, a compressed subtelegram timing has been defined. This would for instance be used in Japan which requires that all transmissions related to one event have to be finished after 50 ms.

Table 11 below summarizes the compressed subtelegram timing.

Repeater Level	Time Offset [ms] First Subtelegram	Time Offset [ms] Second Subtelegram	Time Offset [ms] Third Subtelegram
0 (Original Telegram)	0 ... 1	4 ... 12	14 ... 22
1 (Repeated for the first time)	0 ... 1	4 ... 12	14 ... 22
2 (Repeated for the second time)	0 ... 1	4 ... 12	14 ... 22

**Table 11 – Compressed subtelegram timing**

### **A.3.2 TX maturity time**

The maximum time between the request for transmission and the end of transmission of all subtelegrams is called the TX Maturity Time.

In radio systems using standard subtelegram timing, the TX maturity time is 40 ms because the transmission of the last telegram will start no later than 39 ms after the transmission request. In radio systems using compressed subtelegram timing, the TX maturity time is 25 ms.

After the TX maturity time has elapsed, the host can be sure that all subtelegrams corresponding to the telegram have been transmitted. In practical applications this means for instance that an external controller can power down the transmitter after the TX maturity time has elapsed.

### **A.3.3 RX maturity time**

The maximum time allowed for reception of a radio telegram is called the RX Maturity Time. Identical subtelegrams from the same sender are considered to belong to the same telegram if they are received within the RX maturity time.

In EnOcean radio systems, the RX maturity time is 100 ms.

STM 550 / EMSI – ENOCEAN MULTISENSOR FOR IOT APPLICATIONS

### A.4 Addressing

Each radio transmission within an EnOcean radio network will contain information about the originator (sender) of the transmitted radio telegram.

In addition, the intended receiver of a transmitted telegram can optionally be specified as well. Telegrams where the intended receiver is designated are called Addressed Data Telegram or ADT in short. Telegrams where the intended receiver is not designated are called Broadcast Telegrams.

Different types of addresses can be used to designate sender and receiver of an EnOcean radio telegram.

#### A.4.1 Address types

EnOcean radio systems support three different types of addresses:

- EnOcean Unique Radio ID (EURID)
- Base ID
- Broadcast ID

Each of these three address types corresponds to a specific address or address range as shown Figure 35 below.

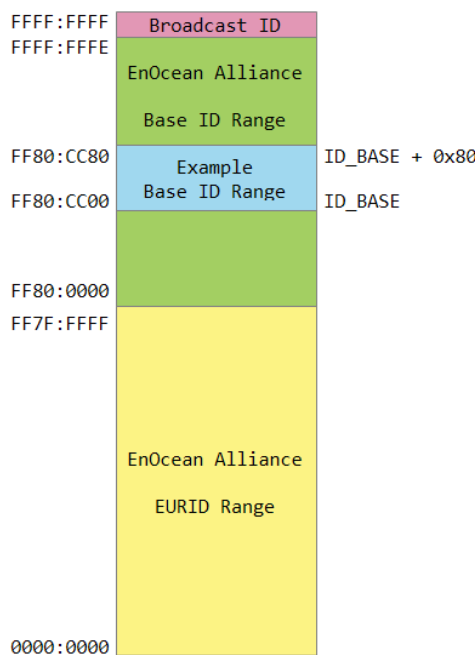

**Figure 35 – Address map of EnOcean radio systems**

STM 550 / EMSI – ENOCEAN MULTISENSOR FOR IOT APPLICATIONS

---

**A.4.2 EURID (Radio ID)**

Each device communicating within an EnOcean radio network contains its own EnOcean Unique Radio ID (EURID) which is assigned by EnOcean Alliance. The EURID uniquely identifies each EnOcean device; no two EnOcean devices can have the same EURID.

When transmitting a radio telegram, the sender might either use the EURID or a selected Base ID (as described below) to identify itself as the originator of the telegram.

In addition, the sender might use the EURID of the intended receiver to designate this as the intended recipient of the telegram. If no receiver is designated, then the radio telegram will be transmitted as a broadcast. In this case, the receivers of such broadcast telegram decide if they accept this telegram.

**A.4.3 Broadcast ID**

The Broadcast ID can be used as destination address instead of the EURID of the intended receiver if a telegram should be received by more than one receiver or if the EURID of the intended receiver is unknown.

Telegrams where the destination address is the Broadcast ID are called "Broadcast Telegrams" and are commonly used by sensors and switches. The Broadcast ID is `0xFFFF:FFFF`. Note that the broadcast ID is not transmitted as part of the radio telegram.

Receivers of broadcast telegrams can decide based on the EURID of the sender (originator) of the telegram if this telegram is relevant for them or not.

**A.4.4 Base ID**

Normally, EnOcean devices will use their own EURID in order to identify themselves as the originator of transmitted telegrams. For very specific use cases, they can instead choose to use an address (ID) from within a defined range of 128 addresses. These 128 addresses are called the Base ID Range of the device.

The Base ID Range (128 addresses) of a device can be allocated anywhere in between `0xFF80:0000` and `0xFFFF:FFFE` (which represents a total range of approximately 8 million addresses). The location of the Base ID Range is defined by the start (lowest) address of the range which will always be aligned on a 7 bit (128) boundary, i.e. the last byte of the start address can be either `0x00` or `0x80`.

Note that Base ID - unlike EURID - are not guaranteed to be globally unique. Many devices with the same Base ID might exist within the EnOcean ecosystem. Having several devices using the same Base ID within a system might lead to undefined system behaviour.

Note also that the use of Base ID is not defined within the scope of secure communication, remote management or smart acknowledge. STM 550 does not support the use of Base ID.



## A.5 Data payload

EnOcean radio systems encode the data using so called EEP (EnOcean Equipment Profile). Each transmitter might choose one (or sometimes several) EEP for data transmission depending on the type of transmitted data.

### A.5.1 EnOcean Equipment Profiles (EEP) structure

EnOcean Equipment Profiles (EEP) are identified using three fields:

- **RORG**  
RORG identifies the high-level telegram type, e.g. rocker switch telegram, four-byte sensor telegram, variable length telegram etc.
- **FUNC**  
FUNC identifies the function group to which this telegram belongs, e.g. the function group of temperature sensors within the four-byte sensor telegram type
- **VARIANT (or TYPE)**  
VARIANT (sometimes also called TYPE) identifies the exact sensor variant within the function group, e.g. a 0 °C – 40 °C temperature sensor that is defined within the function group of temperature sensors

Figure 36 below shows the structure of the EEP identifier.

RORG	FUNC	VARIANT
0x00 ... 0xFF	0x00 ... 0x3F	0x00 ... 0x7F
8 bit	6 bit	7 bit

**Figure 36 – EEP identifier structure**

The complete EEP identifier is typically only transmitted during the initial teach-in (paring) between devices. After that, only the RORG which identifies the high-level telegram is transmitted. Transmission of the RORG allows distinguishing between different telegram types (e.g. data and signal telegrams) originating from the same sender.

STM 550 / EMSI – ENOCEAN MULTISENSOR FOR IOT APPLICATIONS

**A.5.2 Common RORG**

Within EnOcean radio telegrams, the RORG field identifies the telegram type as described in the previous chapter. Table 12 below lists common RORG used for communication in EnOcean systems.

<b>RORG</b>	<b>Description</b>	<b>Typical Use</b>
0x30	Encrypted telegram without RORG of the original telegram	Encrypted switch or magnet contact telegrams
0x31	Secure message that does identify the type (RORG) of the encrypted telegram	Encrypted sensor telegrams
0x32	Decrypted telegram without RORG	Decrypted telegrams from switches or magnet contacts
0x33	Secure chained messages (SEC_CDM)	Encrypted sensor telegrams requiring chaining due to length
0x35	Secure teach-in telegram (SEC_TI)	Setup of a secure communication channel
0xA5	4 Byte Sensor Telegram (4BS)	Common (simple) sensor telegrams expressed with 4 byte payload
0xA6	Addressed data telegram (ADT)	Telegrams that specify the intended receiver
0xC5	Remote management telegram (SYS_EX)	Configuration of functional parameters in the receiver
0xD0	Signal telegram (SIGNAL)	Reporting of system parameters
0xD1	Manufacturer-specific content (MSC)	Manufacturer-defined telegrams
0xD2	Variable length telegram (VLD)	Variable length telegrams requiring more than 4 byte of payload
0xD5	1 Byte sensor telegram (1BS)	Simple sensors with 1 byte payload such as magnet contact sensors
0xF6	Rocker and pushbutton switches (RPS)	Rocker switches or push buttons

**Table 12 – Common RORG used in EnOcean radio systems**

For full details about EnOcean Equipment Profiles (EEP) please refer to the EnOcean Equipment Profiles specification.

### **A.5.3 Data payload size**

The maximum telegram data payload size used by EnOcean radio telegrams is 14 byte of data payload for the case of standard broadcast telegrams. For the case of standard addressed telegrams, the maximum length of the data payload is 9 byte.

If the radio telegram contains security information such as the RLC value or the authentication signature, then the maximum data payload of one EnOcean radio telegram is reduced further according to the size of the security information.

If the telegram data payload exceeds the maximum available data payload then it has to be transmitted as a chain of radio telegrams which together transfer the message payload.

The type of chaining that is used depends on the type of telegram that is transmitted. Standard telegrams are transmitted as Chained Data Messages (CDM) while secure telegrams are transmitted as Secure Chained Data Messages (SEC\_CDM).

## **A.6 Telegram chaining**

Telegram chaining is a feature that allows transmission of a payload that is larger than the maximum supported DATA payload.

For the transmission of a telegram with a data payload larger than 14 byte, the payload is distributed (segmented) across several telegrams using the telegram structure shown below. Upon reception, the payload of the received telegrams is combined (reassembled) into the original telegram and forwarded to the host via the ESP3 interface once the last telegram in the chain has been received.

STM 550 / EMSI – ENOCEAN MULTISENSOR FOR IOT APPLICATIONS

**A.6.1 Telegram chaining for broadcast telegrams**

Chained broadcast telegrams can be identified by the R-ORG 0x40 (CDM). The first telegram in a chain (with `IDX = 0b000000`) uses the `CHAIN_LEN` field to specify the total length of the `DATA` payload that is transported by this chain. Figure 37 below shows the structure of the first telegram in a chain of broadcast telegrams.

0x40 (CDM)	CHAIN_CTRL		CHAIN_LEN	RORG	DATA	SENDER EURID	STATUS	CRC / HASH
	ID	IDX						
1 Byte	1 Byte		2 Byte	1 Byte	10 Byte	4 Byte	1 Byte	1 Byte

**Figure 37 – Structure of the first telegram in a chain of broadcast telegrams**

Subsequent telegrams in the chain (with `IDX > 0b000000`) omit the `CHAIN_LEN` field as shown in Figure 38 below.

0x40 (CDM)	CHAIN_CTRL		RORG	DATA	SENDER EURID	STATUS	CRC / HASH
	ID	IDX					
1 Byte	1 Byte		1 Byte	1 ... 12 Byte	4 Byte	1 Byte	1 Byte

**Figure 38 – Structure of subsequent telegrams in a chain of broadcast telegrams**

Up to 4 telegram chains from the same sender can be in progress at any time. The individual chains are identified by the 2 bit wide `ID` field. Telegrams having the same `ID` field setting are considered to be part of the same chain.

The order of the telegrams within each chain are identified by the 6 bit `IDX` field with the first telegram using `IDX = 0b000000`, the second telegram `IDX = 0b000001` and so on. The maximum length of a telegram chain is therefore 64 telegrams.

The theoretical maximum `DATA` length within a chain of telegrams is 766 byte ( $63 * 12 \text{ byte} + 1 * 10 \text{ byte}$ ).

**A.6.2 Telegram chaining for addressed telegrams (ADT)**

Chained addressed telegrams extend the format of chained broadcast telegrams by adding the `RORG 0xA6` (Addressed Data Telegram) at the begin of the message and `EURID` of the intended receiver of the message before the `EURID` of the sender.

Figure 39 below shows the structure for the first telegram in a chain of addressed telegrams.

0xA6 (ADT)	0x40 (CDM)	CHAIN_CTRL		CHAIN_LEN	RORG	DATA	DESTINATION EURID	SENDER EURID	STATUS	CRC / HASH
		ID	IDX							
1 Byte	1 Byte	1 Byte		2 Byte	1 Byte	5 Byte	4 Byte	4 Byte	1 Byte	1 Byte

**Figure 39 – Structure of the first telegram in a chain of addressed telegrams**

STM 550 / EMSI – ENOCEAN MULTISENSOR FOR IOT APPLICATIONS

Subsequent telegrams in a chain of addressed telegrams omit both the CHAIN\_LEN and the RORG field as shown in Figure 40 below.

0xA6 (ADT)	0x40 (CDM)	CHAIN_CTRL		DATA	DESTINATION EURID	SENDER EURID	STATUS	CRC / HASH
		ID	IDX					
1 Byte	1 Byte	1 Byte		1 ... 8 Byte	4 Byte	4 Byte	1 Byte	1 Byte

**Figure 40 – Structure of subsequent telegrams in a chain of addressed telegrams**

**A.6.3 Telegram chaining for secure telegram (SEC\_CDM)**

Chained secure telegrams – identified by RORG 0x33 (SEC\_CDM) - extend the format of chained broadcast telegrams by defining three different telegram structures – one for the first telegram in a chain, one for the last telegram in a chain and one for all telegrams in between the first and the last.

Figure 41 shows the structure for the first telegram in a chain of secure telegrams.

0x33 (SEC_CDM)	CHAIN_CTRL		CHAIN_LEN	RORG	DATA	SENDER EURID	STATUS	CRC / HASH
	ID	IDX						
1 Byte	1 Byte		2 Byte	1 Byte	10 Byte	4 Byte	1 Byte	1 Byte

**Figure 41 – Structure of the first telegram in a chain of secure telegrams**

Intermediary telegrams in a chain of secure telegrams omit both the CHAIN\_LEN and the RORG field as shown in Figure 42 below.

0x33 (SEC_CDM)	CHAIN_CTRL		DATA	SENDER EURID	STATUS	CRC / HASH
	ID	IDX				
1 Byte	1 Byte		1 ... 13 Byte	4 Byte	1 Byte	1 Byte

**Figure 42 – Structure of intermediary telegrams in a chain of secure telegrams**

The last telegram of the chain contains the rolling code (RLC) value and the message signature (CMAC) as shown in Figure 43 below. Note that the last telegram in a chain of secure telegrams might have no data payload (if the data exactly fits into the previous telegram in the chain).

0x33 (SEC_CDM)	CHAIN_CTRL		DATA	CMAC	RLC	SENDER EURID	STATUS	CRC / HASH
	ID	IDX						
1 Byte	1 Byte		0 ... 5 / 7 Byte	3 / 4 Byte	3 / 4 Byte	4 Byte	1 Byte	1 Byte

**Figure 43 – Structure of the last telegram in a chain of secure telegrams**

STM 550 / EMSI – ENOCEAN MULTISENSOR FOR IOT APPLICATIONS

**A.6.4 Telegram chaining for addressed secure telegram (ADT SEC\_CDM)**

Chained secure telegrams may also be transmitted as addressed telegram (ADT) to identify the intended receiver of this telegram chain.

Chained addressed secure telegrams extend the format of chained secure telegrams by adding the RORG 0xA6 (Addressed Data Telegram) at the begin of the message and EURID of the intended receiver of the message before the EURID of the sender.

Figure 44 below shows the structure for the first telegram in a chain of secure telegrams.

0xA6 (ADT)	0x33 (SEC_CDM)	CHAIN_CTRL		CHAIN_LEN	RORG	DATA	DESTINATION EURID	SENDER EURID	STATUS	CRC / HASH
		ID	IDX							
1 Byte	1 Byte	1 Byte		2 Byte	1 Byte	5 Byte	4 Byte	4 Byte	1 Byte	1 Byte

**Figure 44 – First telegram in a chain of addressed secure telegrams**

Intermediary telegrams in a chain of secure telegrams omit both the CHAIN\_LEN and the RORG field as shown in Figure 45 below.

0xA6 (ADT)	0x33 (SEC_CDM)	CHAIN_CTRL		DATA	DESITNATION EURID	SENDER EURID	STATUS	CRC / HASH
		ID	IDX					
1 Byte	1 Byte	1 Byte		1 ... 8 Byte	4 Byte	4 Byte	1 Byte	1 Byte

**Figure 45 – Intermediary telegrams in a chain of addressed secure telegrams**

The last telegram of the chain contains the rolling code (RLC) value and the message signature (CMAC) as shown in Figure 46 below.

0xA6 (ADT)	0x33 (SEC_CDM)	CHAIN_CTRL		DATA	CMAC	RLC	DESTINATION EURID	SENDER EURID	STATUS	CRC / HASH
		ID	IDX							
1 Byte	1 Byte	1 Byte		0 ... 5 / 7 Byte	3 / 4 Byte	3 / 4 Byte	4 Byte	4 Byte	1 Byte	1 Byte

**Figure 46 – Last telegram in a chain of addressed secure telegrams**

Note that the encapsulation as addressed (ADT) telegram is applied after the SEC\_CDM telegram has been formed. The last SEC\_CDM telegram might therefore be split into two addressed SEC\_CDM telegrams due to the addition of the RORG and DESTINATION EURID addressing fields resulting in a telegram size larger than the maximum size of EnOcean radio telegrams.

## B. Introduction to EnOcean security protocol

This chapter gives a high-level introduction to key aspects of the security protocol used in EnOcean radio networks to help the understanding of security-related features of STM 550.

Refer to the EnOcean Alliance Security Specification for a detailed up to date description of all features.

### B.1 Goals of secure radio communication

Secure radio communication aims to address two main issues:

- Unauthorized interception (reception and correct interpretation) of transmitted data  
In doing so, a third (unauthorized) party is able to understand the content of a received content.
- Unauthorized transmission of radio telegrams  
In doing so, a third (unauthorized) party is able to transmit a radio telegram that is treated by a receiver as valid request.

Somewhat loosely speaking, the goal of security is to prevent an unauthorized person (often referred to as an *Attacker*) both from learning about the current state of a system and from actively changing it.

These goals can be achieved via techniques such as telegram encryption, telegram authorization and dynamic modification. All three techniques will be reviewed in the subsequent chapters for reference.

## B.2 Telegram encryption

The goal of telegram encryption is to prevent unauthorized receivers from correctly interpreting the content of a telegram.

In order to do so, the original (plain text) data is *encrypted* with a *security key* thus transforming it into encrypted, unreadable data. Only when the correct key is known it is possible to transform – *decrypt* – the encrypted data into readable data again. Figure 47 below shows the concept.

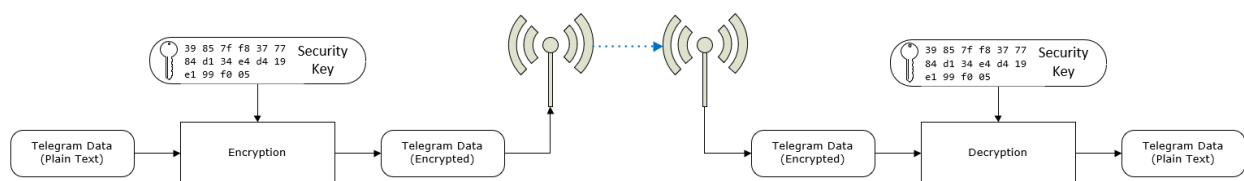

**Figure 47 – Telegram encryption**

If the same security key is used for encryption at the sender and decryption at the receiver then this is called a *symmetric key* algorithm. AES (AES128 / AES256) and DES / 3DES algorithms are typical examples of this category. EnOcean radio systems use this approach.

If different security keys are used for encryption at the sender and decryption at the receiver then this is called an *asymmetric key* algorithm or a *public key* algorithm. Public / private key algorithms such as PGP, GPG or TLS fall into this category. EnOcean radio systems do not support asymmetric key algorithms.

## B.3 Telegram authentication

The goal of telegram authentication is to prevent unauthorized senders to transmit apparently valid commands causing the receiver to perform unauthorized actions. Telegram authentication is typically used in conjunction with telegram encryption.

Telegram authentication works by creating a *signature* (often called *Cipher-based Message Authentication Code* or *CMAC* in short) based on the content of the telegram and the security key.

Essentially, the telegram data is transformed via a defined algorithm using the security key into a unique, fixed size signature (where typical signature lengths include 24 bit, 32 bit, 512 bit and 1024 bit) which identifies this specific message.

For an optimal signature algorithm, the likelihood of two different telegrams creating the same telegram signature should be inversely proportional to the signature size, so for instance for 24 bit signatures the likelihood should be one in 16 million and for 32 bit signatures it should be one in 4 billion.



STM 550 / EMSI – ENOCEAN MULTISENSOR FOR IOT APPLICATIONS

Conceptually the correspondence between telegram content and telegram signature is like the one between a person and a fingerprint:

- Each person has a unique fingerprint. Based on a given person one can determine her or his fingerprint
- Based on a given fingerprint one can check if it originated from a given person
- Based on the fingerprint one cannot determine any other properties of the person

For telegram authentication purposes, the telegram signature (CMAC) is usually appended to the telegram content so that the telegram content and the telegram signature are transmitted together.

When the receiver receives such a telegram, it will itself calculate the telegram signature (CMAC) based on the security key and the telegram content. The receiver then compares the signature that it calculated with the signature it received as part of the telegram.

If both signatures are the same, then the receiver can establish two important facts:

1. The telegram originates from a sender knowing the security key
2. The content of the telegram has not been modified after the sender added the signature to it

Figure 48 below illustrates the concept of telegram authorization via a telegram signature.

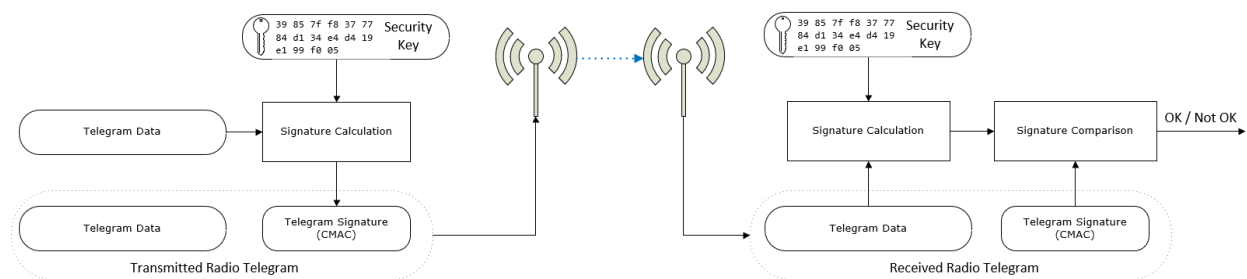

**Figure 48 – Telegram authentication via telegram signature**

### B.4 Replay protection

One fundamental problem with both telegram encryption and telegram authorization is that using the same input data (plain text) with the same security key will always result in the same encrypted data and the same signature. This enables attacks based on monitoring previous system behaviour. If an attacker has observed that a certain data telegram results in a certain light being turned on, then he could use this information to identify - or even actively send - similar telegrams in the future. This type of attack is often called *Replay Attack* since it works by reusing (replaying) previously transmitted (valid) data telegrams.

In order to prevent this type of attack, either the telegram data or the security material (e.g. the security key or the initialization vector / nonce) must change to ensure that identical input data does not create identical encrypted radio telegrams.

The change of telegram data or security material is done based on a sequence of values that are guaranteed to be unique so that the same value will not be used twice. This sequence of changing values is often referred to as *Rolling Code* or *RLC* in short.

In order to prevent replay of an already received message, the receiver will keep track of the latest received RLC value and will only accept telegrams with an RLC value that comes later (after the last received RLC value) in the sequence.

Both sender and receiver have to know the mechanism how to generate the next RLC (the next value in the sequence) based on the current RLC (the current value of the sequence). The easiest - and most common - approach for that is to use the value of a monotonously incrementing counter that is incremented for each telegram.

Such counter is often referred to as *Sequence Counter*; the current value of the sequence counter is the RLC. Figure 49 shows the concept of adding an RLC to the telegram data.

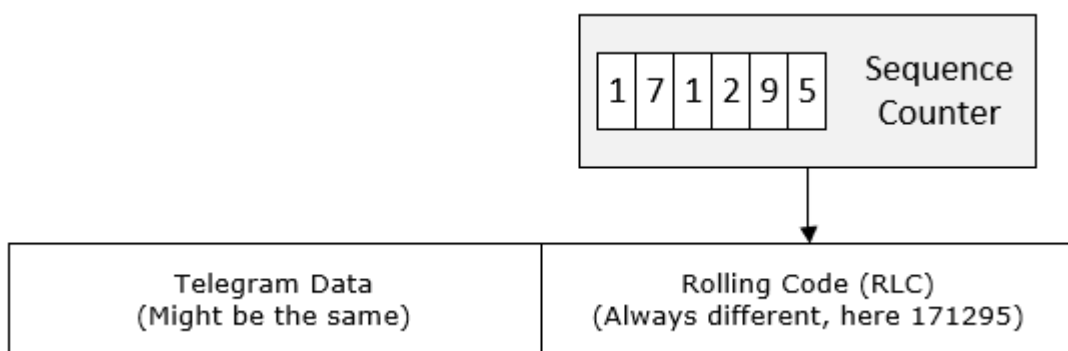
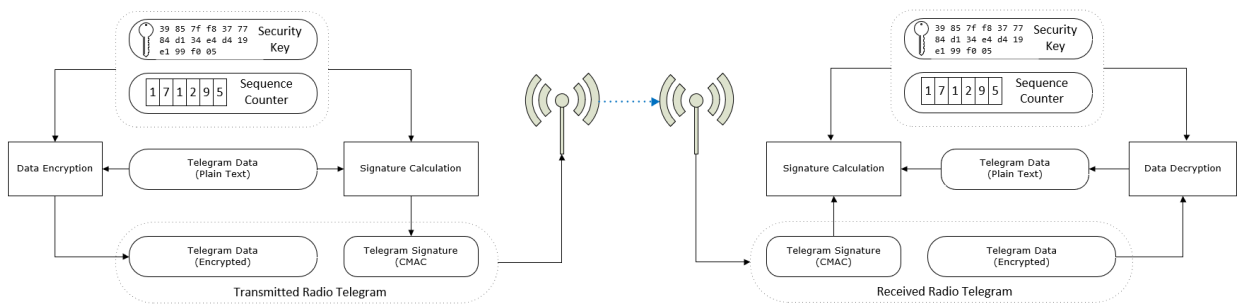

**Figure 49 – Addition of an RLC to the telegram data**

## STM 550 / EMSI – ENOCEAN MULTISENSOR FOR IOT APPLICATIONS

EnOcean radio systems use an approach where the RLC is used to change the security material (specifically, the initialization vector – often called *Nonce* - used by the security algorithms together with the security key) to ensure that the encrypted telegram payload and the telegram signature change even when the content of the telegram itself stays the same.

Figure 50 below illustrates this approach.



**Figure 50 – Encryption and authentication**

STM 550 / EMSI – ENOCEAN MULTISENSOR FOR IOT APPLICATIONS

**B.4.1 RLC and security key in bi-directional communication**

If the communication between two devices (*Device1* and *Device2*) is bi-directional, i.e. each device can either transmit or receive telegrams, then two independent RLC (*RLC1* and *RLC2*) have to be used (since the number of telegrams one direction might be different from the number of telegrams in the other direction) and two different security Keys (*Key1* and *Key2*) might be used (using the same key in both directions would also be possible).

The first pair (RLC1, Key1) will be used for the telegram transmission from Device1 to Device2 while the second pair (RLC2, Key2) will be used for the telegram transmission from Device2 to Device1.

Device1 will store RLC1 and Key1 together with the address of Device2 in its so-called *outbound secure link table* since they are used for transmission of telegrams to the remote device. RLC2 and Key2 together with the address of Device2 will be stored in its so-called *inbound secure link table* since they are used for reception of telegrams from the remote device.

Conversely, Device2 will store RLC1 and Key1 together with the address of Device1 in its inbound secure link table and RLC2 and Key2 together with the address of Device1 in its outbound secure link table. Figure 51 below illustrates that.

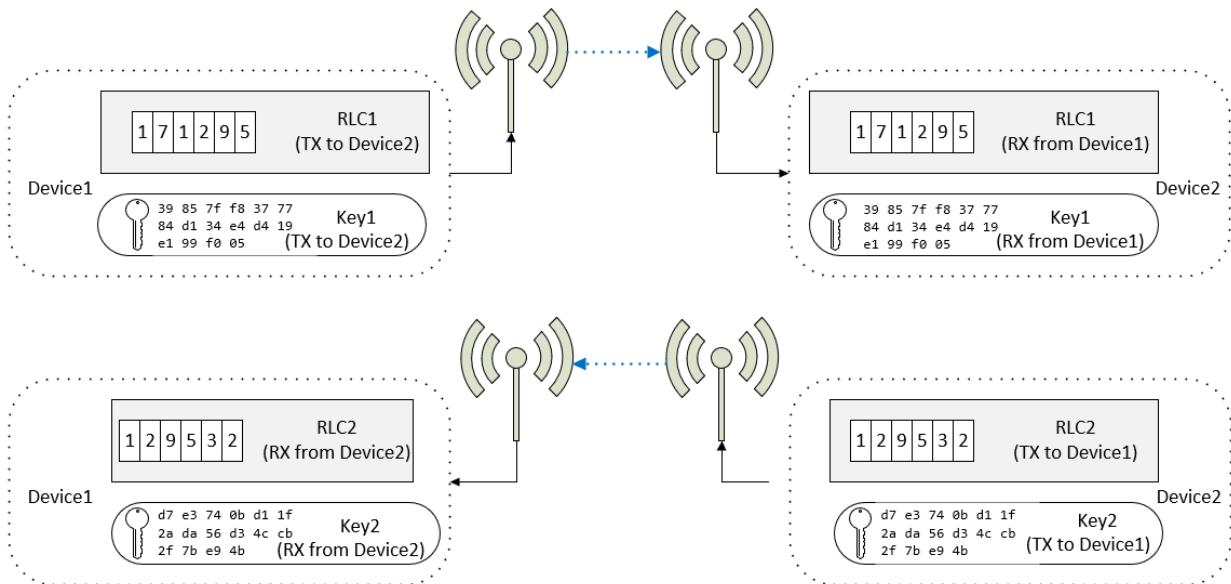

**Figure 51 – Security key and RLC usage in bi-directional communication**

#### **B.4.2 RLC synchronization between sender and receiver**

For encryption and authentication using RLC, it is important that the RLC on the transmitter side and the RLC on the receiver side remain synchronized, i.e. that they always have the same value.

This can be ensured either by transmitting the RLC as part of the telegram (this is called *explicit RLC mode*) or by tracking the expected RLC when it is not transmitted as part of the telegram (this is called *implicit RLC mode*).

Explicit RLC mode is the recommended procedure since it ensures that the receiver always knows the current RLC used by the sender; it requires however to increase the size of the telegram in order to transmit this RLC.

Implicit RLC mode might be used in energy-constrained systems where there might not be enough energy to additionally transmit the current RLC as part of the telegram.

For implicit RLC mode, the initial value of the RLC at the sender and at the receiver will be aligned during the establishment of the secure communication so that the receiver knows the current RLC used by the sender.

After that, both sender and receiver will adjust (increment for the case of using a sequence counter to generate the RLC) the RLC for each telegram that is transmitted to this specific receiver (RLC adjustment in the sender) or received from this specific sender (RLC adjustment in the receiver).

In order to guard against the case of telegrams being lost (not received by the receiver), the receiver will check if the RLC it assumes is used in the received telegram will result in a matching message signature (CMAC) when executing telegram authentication using this RLC together with the security key.

If this is the case, then the receiver will decrypt the telegram content using this RLC together with the security key. If this is not the case, then the receiver can retry using the next RLC in the sequence and so on. Typically, a maximum number of future RLC values to be tried will be defined. This parameter is often referred to as the *Rolling Code Window Size*.

If message decryption based on a future RLC is successful then the RLC used by the receiver will be updated to this value, thereby re-synchronizing the transmitter and receiver RLC. If no matching RLC is found within the rolling code window, then the message cannot be decrypted and authenticated and might be forwarded to the host for further analysis.

**B.4.3 Secure telegram types**

Secure communication is based on two telegram types:

- Secure teach-in telegrams are used to establish a secure communication channel by providing the receiver with the required information to decrypt and authenticate received secure data telegrams
- Secure data telegrams are used to securely transmit data

The format of these two telegram types is described in the subsequent chapters.

**B.4.3.1 Secure teach-in telegram**

Teach-in is the process by which a sender communicates to a receiver the parameters required to decrypt and authenticate received secure telegrams. These parameters can be communicated from the sender to the receiver by transmitting a secure teach-in telegram with the structure shown in Figure 52 below.

RORG (0x35: SEC_TI)	TEACH-IN INFO	SECURITY FORMAT (SLF)	CURRENT RLC VALUE	SECURITY KEY
1 byte	1 byte	1 byte	2 / 3 / 4 byte	16 byte

**Figure 52 – Secure teach-in telegram structure**

The secure teach-in telegram contains the following parameters:

- RORG 0x35 (SEC\_TI)  
Secure teach-in telegrams are identified by the RORG 0x35 (SEC\_TI)
- Teach-in Info  
This field contains information about the secure teach-in telegram allowing the receiver to properly it. The structure of the Teach-in Info field is shown below.
- SLF  
The SLF specifies the type of encryption and authentication used by for the communication with the remote device as described in chapter B.4.3.3.
- RLC  
This field contains the current value of the RLC used by the sender.
- Key  
The 128 bit security key is used by the sender to encrypt and authenticate the transmitted telegram and by the receiver to decrypt and authenticate the received telegram

STM 550 / EMSI – ENOCEAN MULTISENSOR FOR IOT APPLICATIONS

**B.4.3.2 Teach-in Info**

Figure 53 below shows the structure of the Teach-in Info field.

TEACH IN INFO							
Bit 7	Bit 6	Bit 5	Bit 4	Bit 3	Bit 2	Bit 1	Bit 0
IDX		CNT		PSK	TYPE	INFO	
0b00: 1st segment 0b01: 2nd segment 0b10, 0b11: Unused		If IDX = 0b00: Total number of segments 0b00: 1 segment 0b01: 2 segments 0b10, 0b11: Unused		If IDX = 0b00: 0b0: PSK not used 0b1: PSK used	If IDX = 0b00: 0b0: Is not PTM 0b1: Is PTM	If IDX = 0b00 and TYPE = 0b0: 0b00: Unidirectional teach-in 0b01: Bi-directional teach-in  If IDX = 0b00 and TYPE = 0b1: 0b00: Rocker A used for teach-in 0b01: Rocker B used for teach-in	

**Figure 53 – Teach-in Info structure**

**B.4.3.3 Security level format (SLF)**

The security level format (SLF) defines the security parameters used for communication between two devices. If the communication is bi-directional (send and receive) then the same SLF setting has to be used in both directions.

Figure 54 below shows the supported security parameter options of the SLF field.

7	6	5	4	3	2	1	0
RLC_MODE			CMAC_SIZE		ENCRYPTION_ALGO		
0b000: No RLC algorithm 0b001: RFU 0b010: 16 bit RLC (not transmitted) 0b011: 16 bit RLC (16 bit transmitted) 0b100: 24 bit RLC (not transmitted) 0b101: 24 bit RLC (24 bit transmitted) 0b110: 32 bit RLC (24 bit transmitted) 0b111: 32 bit RLC (32 bit transmitted)			0b00: No MAC 0b01: 3 byte CMAC 0b10: 4 byte CMAC 0b11: RFU		0b000: No data encryption 0b001: Deprecated 0b010: Deprecated 0b011: VAES using AES128 0b100: AES-CBC using AES128 Others: RFU		

**Figure 54 – SLF structure**