

PTM 535Z – 2.4 GHz Pushbutton Transmitter

PTM 535Z 2.4 GHz Pushbutton Transmitter

21 July 2017



Observe precautions! Electrostatic sensitive devices!

Patent protected:

WO98/36395, DE 100 25 561, DE 101 50 128,
WO 2004/051591, DE 103 01 678 A1, DE 10309334,
WO 04/109236, WO 05/096482, WO 02/095707,
US 6,747,573, US 7,019,241

PTM 535Z – 2.4 GHz Pushbutton Transmitter

REVISION HISTORY

The following major modifications and improvements have been made to this document:

Version	Author	Reviewer	Date	Major Changes
1.0	MKA	MH, MF	01.03.2016	Initial Release
1.1	MKA		02.05.2016	Minor corrections
1.2	MKA		31.05.2016	Added appendix on telegram analysis
1.3	MKA		29.07.2016	Clarified radio channel selection sequence
1.4	MKA		24.10.2016	Added data rate
1.5	MKA		21.07.2017	Added ARIB certificate, label and soldering information

**Published by EnOcean GmbH, Kolpingring 18a, 82041 Oberhaching, Germany
www.enocean.com, info@enocean.com, phone +49 (89) 6734 6890**

© EnOcean GmbH, All Rights Reserved

Important!

This information describes the type of component and shall not be considered as assured characteristics. No responsibility is assumed for possible omissions or inaccuracies. Circuitry and specifications are subject to change without notice. For the latest product specifications, refer to the EnOcean website: <http://www.enocean.com>.

As far as patents or other rights of third parties are concerned, liability is only assumed for modules, not for the described applications, processes and circuits.

EnOcean does not assume responsibility for use of modules described and limits its liability to the replacement of modules determined to be defective due to workmanship. Devices or systems containing RF components must meet the essential requirements of the local legal authorities.

The modules must not be used in any relation with equipment that supports, directly or indirectly, human health or life or with applications that can result in danger for people, animals or real value.

Components of the modules are considered and should be disposed of as hazardous waste. Local government regulations are to be observed.

Packing: Please use the recycling operators known to you.

PTM 535Z – 2.4 GHz Pushbutton Transmitter

TABLE OF CONTENT

1	GENERAL DESCRIPTION	5
1.1	Basic functionality	5
1.2	Technical data.....	6
1.3	Physical dimensions.....	6
1.4	Environmental conditions.....	6
1.5	Packaging information.....	6
1.6	Ordering information.....	6
2	FUNCTIONAL INFORMATION	7
2.1	PTM 535Z Device Overview.....	7
2.2	Basic functionality	7
2.3	Device interface signals.....	8
2.4	Power supply	8
2.5	Input signals.....	9
2.5.1	PTM 535Z input status encoding	9
2.6	Hardware configuration interface.....	10
2.6.1	Hardware-based security mode selection	10
2.6.2	Hardware-based radio channel selection	11
2.7	Radio interface.....	12
2.7.1	Antenna.....	12
2.7.2	Supported radio channels	12
2.7.3	Radio channel selection	13
2.8	Operation modes.....	14
2.8.1	Data mode.....	14
2.8.2	Commissioning mode	15
2.8.2.1	Entry into commissioning mode	16
2.8.2.2	Commissioning telegram.....	16
2.8.2.3	Radio channel adjustment.....	16
2.8.2.4	Determining the correct radio channel	17
2.8.2.5	Storing the new radio channel and return to data mode.....	17
2.9	Security modes.....	18
2.9.1	Selecting the security mode	18
2.9.2	Security parameters.....	18
2.10	Number of redundant telegrams.....	19
3	IEEE 802.15.4 Frame Structure	20
3.1	PHY Header	21
3.2	MAC Header.....	22
3.3	MAC Trailer.....	22
3.4	MAC Payload.....	22

PTM 535Z – 2.4 GHz Pushbutton Transmitter

- 3.4.1 MAC payload structure for secure data telegrams..... 23
- 3.4.2 MAC payload structure for secure commissioning telegrams 24
- 3.4.3 MAC payload structure for standard data telegrams 25
- 3.4.4 MAC payload for standard commissioning telegrams..... 26
- 4 Device Integration 27
- 4.1 Mechanical outline 27
- 4.2 Soldering information..... 28
- 5 APPLICATION INFORMATION..... 29
- 5.1 Transmission range 29
- 5.2 Duty Cycle..... 29
- 5.3 Device PCB label 30
- 6 REGULATORY INFORMATION..... 31
- 6.1 FCC (United States) Certification 31
 - 6.1.1 FCC (United States) Labeling Requirements 31
 - 6.1.2 FCC (United States) Certificate 32
 - 6.1.3 FCC (United States) Regulatory Statement..... 33
- 6.2 IC (Industry Canada) Certification 34
 - 6.2.1 IC (Industry Canada) Labeling Requirements 34
 - 6.2.2 IC (Industry Canada) Certificate 35
 - 6.2.3 IC (Industry Canada) Regulatory Statement..... 36
- 6.3 ARIB (Japan) Certification..... 37
 - 6.3.1 ARIB (Japan) Certificate 37
- A Understanding PTM 535Z telegram structure..... 38
 - A.1 Installation instructions for TI CC2531 packet sniffer 38
 - A.1.1 CC2531EMK setup 38
 - A.2 Configuration 39
 - A.3 Data capture..... 41
 - A.4 Interpretation of the telegram data..... 42
 - A.4.1 MAC Payload..... 42
 - A.4.2 Device ID 42
 - A.4.3 Sequence Counter 42
 - A.4.4 Command payload 43
 - A.4.5 Telegram Signature 43

PTM 535Z – 2.4 GHz Pushbutton Transmitter

1 GENERAL DESCRIPTION

1.1 Basic functionality

PTM 535Z enables the realization of energy harvesting wireless switches for EnOcean systems communicating based on the 2.4 GHz IEEE 802.15.4 radio standard.

PTM 535Z is primarily intended for operation in conjunction with the EnOcean ECO 200 or ECO 250 kinetic energy harvesters. ECO 200 and ECO 250 can be connected to PTM 535Z either mechanically (using two contact pairs) or electrically (using a wired connection to the external interface of PTM 535Z).

Upon detection of energy pulses from the ECO 200 or ECO 250 harvester, PTM 535Z will read the status of additional input signals (on-board meander contact, external input signals) and report the result as IEEE 802.15.4 radio telegram. Both secure and normal transmission modes are supported.

PTM 535Z telegram format has been defined to maximize compatibility with a wide range of devices including such supporting the ZigBee Green Power standard. PTM 535Z radio telegrams are protected with AES-128 security based on a device-unique private key.

PTM 535Z contains a learn button (LRN) to send dedicated commissioning telegrams and to change the radio channel. Radio channel and security mode can also be selected using the hardware configuration interface consisting of six zero Ohm resistor pads (R1 ... R6).

PTM 535Z provides a five pad external electrical interface with the following signals:

- External connection to ECO 200 or ECO 250 (AC1 and AC2)
- Two external input signals (IN1 and IN2)
- Ground (GND)

PTM 535Z is mechanically compatible with the outline of existing PTM 33x modules. Figure 1 below shows PTM 535Z.

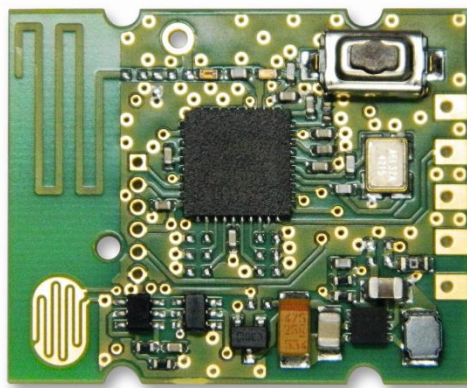

Figure 1 – PTM 535Z Product Outline

PTM 535Z – 2.4 GHz Pushbutton Transmitter

1.2 Technical data

Antenna	Integrated PCB antenna External 50 Ohm whip antenna (optional)
Radio Standard / Data Rate	IEEE 802.15.4 (2.4 GHz) / 250 kbps
Supported Radio Channels	IEEE 802.15.4 Radio Channel 11 ... 26 (Default: Radio Channel 11)
Radio Channel Selection	HW-configurable (0 Ohm resistor pads) User-selectable (Commissioning)
Commissioning	Learn Button (on-board)
Security	AES128 with Sequence Code (Can be disabled via HW configuration)
Transmit Power (typ, at 25°C)	+2 dBm
Power Supply	ECO 200 Kinetic Energy Harvester
Harvester Interface	2 pairs of contacts
On-board Button Interface	1 meander contact
External Interface	5 pins (solderable) 2 ECO 200 contacts, 2 button inputs, Ground
Certification	RED (Europe), FCC (US), ISED (Canada), ARIB (Japan)

1.3 Physical dimensions

Module Dimensions	26.2 x 21.15 x 3.5 mm
Module Weight	2g

1.4 Environmental conditions

Operating Temperature	-25°C ... 65°C
Storage Temperature	-25°C ... 65°C
Humidity	0% to 95% r.h. (non-condensing)

1.5 Packaging information

Packaging Unit	100 units
Packaging Method	Tray / Box (10 units per tray, 10 trays per box)

1.6 Ordering information

Type	Ordering Code	Frequency
PTM 535Z	S3071-A535	2.4 GHz (IEE 802.15.4)

PTM 535Z – 2.4 GHz Pushbutton Transmitter

2 FUNCTIONAL INFORMATION

2.1 PTM 535Z Device Overview

The radio transmitter device PTM 535Z from EnOcean enables the implementation of wireless remote controls without batteries. Power is provided by an external power generator (typically ECO 200 or ECO 250).

PTM 535Z device transmits data based on the 2.4GHz IEEE 802.15.4 standard. Key components of PTM 535Z are shown on the picture below.

Note that two contact pairs of AC1 and AC2 are located on the bottom side of the PCB and therefore not visible in the picture.

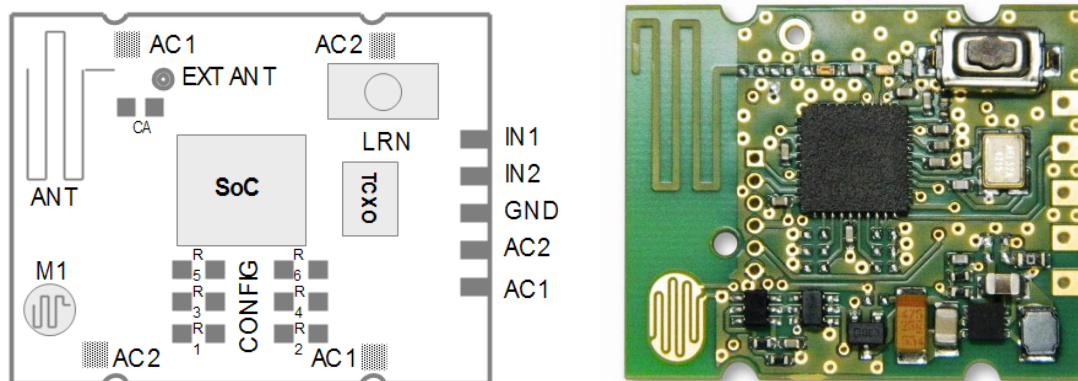

Figure 2 – Electro-dynamic powered radio transmitter device PTM 535Z

2.2 Basic functionality

PTM 535Z devices contain an interface with two pair of signals (AC1 and AC2) used to connect an external energy generator (ECO 200 or ECO 250). Having two contact pairs improves the mechanical design flexibility.

Upon detection of an energy pulse, PTM 535Z reports the status of the on-board meander contact (M1), the external input signals IN1 and IN2 and the polarity of ECO 200 or ECO 250 action (press or release).

“Press” is defined within the scope of this document as a move of a mechanically connected ECO 200 or ECO 250 away from the PTM 535Z PCB while “Release” is defined as a move towards the PTM 535Z PCB

Radio telegrams are transmitted using the on-board antenna (ANT). An external antenna (EXT_ANT) can optionally be used, capacitor CA needs to be removed in that case. Radio telegram format has been defined to maximize compatibility with a wide range of devices including such supporting the ZigBee Green Power standard.

PTM 535Z – 2.4 GHz Pushbutton Transmitter

2.3 Device interface signals

Table 1 below summarizes key elements and interface signals of PTM 535Z.

NAME	DESCRIPTION	NAME	DESCRIPTION
AC1	Input 1 from ECO 200 / 250	AC2	Input 2 from ECO 200 / 250
IN1	External input 1	IN2	External input 2
ANT	On-board PCB antenna	EXT_ANT	External antenna
M1	Meander contact	LRN	Learn button
R1 ... R6	Configuration resistors	GND	Ground

Table 1: PTM 535Z key elements and interface signals

The PTM 535Z device interface is described in more detail below.

2.4 Power supply

PTM 535Z is intended to be supplied by a connected ECO 200 kinetic energy harvester. ECO 200 can be connected to PTM 535Z in the following ways:

- Mechanical connection to one of the two pairs of AC1 / AC2 pads
Use of a suitable mechanical design is required to reliably fixate the ECO 200 or ECO 250 contacts with the AC1 / AC2 connection pads
- Electrically connected using the AC1 / AC2 signals of the external interface

Figure 3 below illustrates the mechanical connection between an ECO 200 kinetic energy harvester and PTM 535Z.

Note that two pairs of contacts are provided by PTM 535Z to enable two orientations of ECO 200 or ECO 250 (spring facing down = red lines / spring facing up = yellow lines) depending on the requirements of the customer mechanical design.

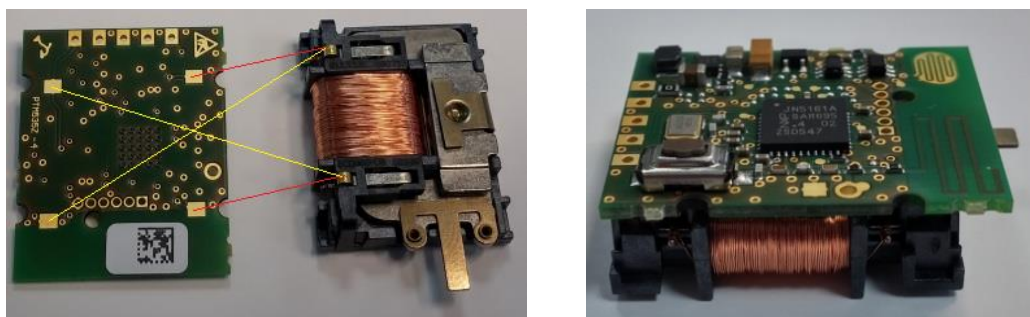

Figure 3: Mechanical connection between ECO 200 / ECO 250 and PTM 535Z

PTM 535Z – 2.4 GHz Pushbutton Transmitter

2.5 Input signals

PTM 535Z data transmits telegrams indicating the status of the following input signals:

- ECO 200 / ECO 250 action direction (press or release)
Press indicates a move away from the PCB (and the ECO 200 / ECO 250 contacts)
Release indicates a move towards the PCB (and the ECO 200 / ECO 250 contacts)
- On-board meander contact (M1)
This meander contact is intended for use with a conductive rubber button and is considered to be active if it is closed.
Contact EnOcean for reference on suitable rubber contact mats if required.
- External input signals (IN1 and IN2)
PTM 535Z provides an internal pull-up resistor on these signals.
These inputs are considered active if they are connected to Ground (GND).

2.5.1 PTM 535Z input status encoding

Table 2 below shows the encoding used by PTM 535Z.

Input 2 (IN2)	Input 1 (IN1)	Meander (M1)	ECO 200 / 250	Command
0 = Not Connected to GND 1 = Connected to GND		0 = Open 1 = Closed	Press= Move away from PCB Release = Move towards PCB	
0	0	0	Release	0x23
0	0	0	Press	0x22
0	0	1	Release	0x12
0	0	1	Press	0x13
0	1	0	Release	0x14
0	1	0	Press	0x15
0	1	1	Release	0x16
0	1	1	Press	0x17
1	0	0	Release	0x18
1	0	0	Press	0x19
1	0	1	Release	0x1A
1	0	1	Press	0x1B
1	1	0	Release	0x1C
1	1	0	Press	0x1D
1	1	1	Release	0x1E
1	1	1	Press	0x1F

Table 2: PTM 535Z input status encoding

2.6 Hardware configuration interface

PTM 535Z provides a hardware configuration interface based on six zero Ohm resistor footprints (R1 ... R6).

Populating these resistors allows customer-specific adaption of the following parameters:

- Hardware-based security mode selection
- Hardware-based radio channel selection

2.6.1 Hardware-based security mode selection

By default, PTM 535Z transmits securely authenticated data telegrams based on AES128 encryption standard using a 16 byte device-unique secret key and a 4 byte sequence counter.

For certain applications it might be desirable to transmit data telegrams without sequence counter and device security key / telegram signature. PTM 535Z can be configured to do so by populating configuration resistor R2.

PTM 535Z – 2.4 GHz Pushbutton Transmitter

2.6.2 Hardware-based radio channel selection

By default, the radio channel used by PTM 535Z can be changed by the user during commissioning as described in chapter 2.8.2.3.

For certain applications it is desirable to pre-configure the radio channel in a way that it cannot be modified by the user.

This can be achieved by populating configuration resistor R1. If this resistor is populated then the radio channel used by PTM 535Z will exclusively be determined by configuration resistors R3 ... R6 as shown in Table 3 below.

Using the LRN button, the user will trigger the transmission of a commissioning telegram, but he cannot modify the radio channel.

R3	R4	R5	R6	Channel
Not populated	Not populated	Not populated	Not populated	11
Not populated	Not populated	Not populated	Populated	12
Not populated	Not populated	Populated	Not populated	13
Not populated	Not populated	Populated	Populated	14
Not populated	Populated	Not populated	Not populated	15
Not populated	Populated	Not populated	Populated	16
Not populated	Populated	Populated	Not populated	17
Not populated	Populated	Populated	Populated	18
Populated	Not populated	Not populated	Not populated	19
Populated	Not populated	Not populated	Populated	20
Populated	Not populated	Populated	Not populated	21
Populated	Not populated	Populated	Populated	22
Populated	Populated	Not populated	Not populated	23
Populated	Populated	Not populated	Populated	24
Populated	Populated	Populated	Not populated	25
Populated	Populated	Populated	Populated	26

Table 3: Resistor encoding for HW-based radio channel selection

PTM 535Z – 2.4 GHz Pushbutton Transmitter

2.7 Radio interface

2.7.1 Antenna

PTM 535Z transmits data based on an on-board PCB antenna (ANT). An external 50Ω whip antenna connected to the EXT_ANT pin can alternatively be used. Connection to the internal antenna has to be cut in this case by removing capacitor CA.

Please check with EnOcean if you intend to use an external antenna.

2.7.2 Supported radio channels

PTM 535Z supports all sixteen IEEE 802.15.4 radio channels in the 2.4 GHz band (channels 11 ... 26 according to IEEE 802.15.4 notation).

Table 4 below shows the correspondence between channel number and channel frequency (in MHz).

Channel ID	Lower Frequency	Centre Frequency	Upper Frequency
11	2404	2405	2406
12	2409	2410	2411
13	2414	2415	2416
14	2419	2420	2421
15	2424	2425	2426
16	2429	2430	2431
17	2434	2435	2436
18	2439	2440	2441
19	2444	2445	2446
20	2449	2450	2451
21	2454	2455	2456
22	2459	2460	2461
23	2464	2465	2466
24	2469	2470	2471
25	2474	2475	2476
26	2479	2480	2481

Table 4: IEEE 802.15.4 Radio Channels and Frequencies (in MHz)

2.7.3 Radio channel selection

The radio channel used by PTM 535Z can be selected in two ways:

- User selection (using LRN button, default mode)
If configuration resistor R1 is not populated (default) then the radio channel can be selected by the user as described in chapter 2.8.2.3
- HW selection (using configuration resistors, requires R1 to be populated)
If configuration resistor R1 is populated then the radio channel used by PTM 535Z is fixed exclusively by the configuration resistors R3 ... R6 as discussed in chapter 2.6.2.

PTM 535Z – 2.4 GHz Pushbutton Transmitter

2.8 Operation modes

PTM 535Z can operate in two modes:

- Data mode
Data mode is used to transmit data telegrams reporting the status of PTM 535Z button inputs
- Commissioning mode
Commissioning mode is used to commission (learn, teach-in) PTM 535Z into a specific receiver or network. To do so, PTM 535Z will identify its capabilities and its security parameters and – if required – change the radio channel it uses for telegram transmission.

2.8.1 Data mode

Data mode is the standard mode of operation. In this mode, PTM 535Z will transmit data telegrams identifying the status of its inputs.

PTM 535Z uses the following sequence to identify and transmit input status:

1. Determine polarity of ECO 200 / ECO 250 pulse (identify press or release direction)
2. Read input status of all signals
3. Calculate data part of IEEE 802.15.4 radio telegram
4. Calculate security part of IEEE 802.15.4 radio telegram (if security is enabled)
5. Transmit radio telegram

PTM 535Z – 2.4 GHz Pushbutton Transmitter

2.8.2 Commissioning mode

Commissioning mode provides two key functions:

- Transmission of a commissioning telegram in order to learn-in PTM 535Z into a network
- Radio channel selection in order to set the radio channel of PTM 535Z to that used by the network

Figure 4 below shows the commissioning state chart used by PTM 535Z.

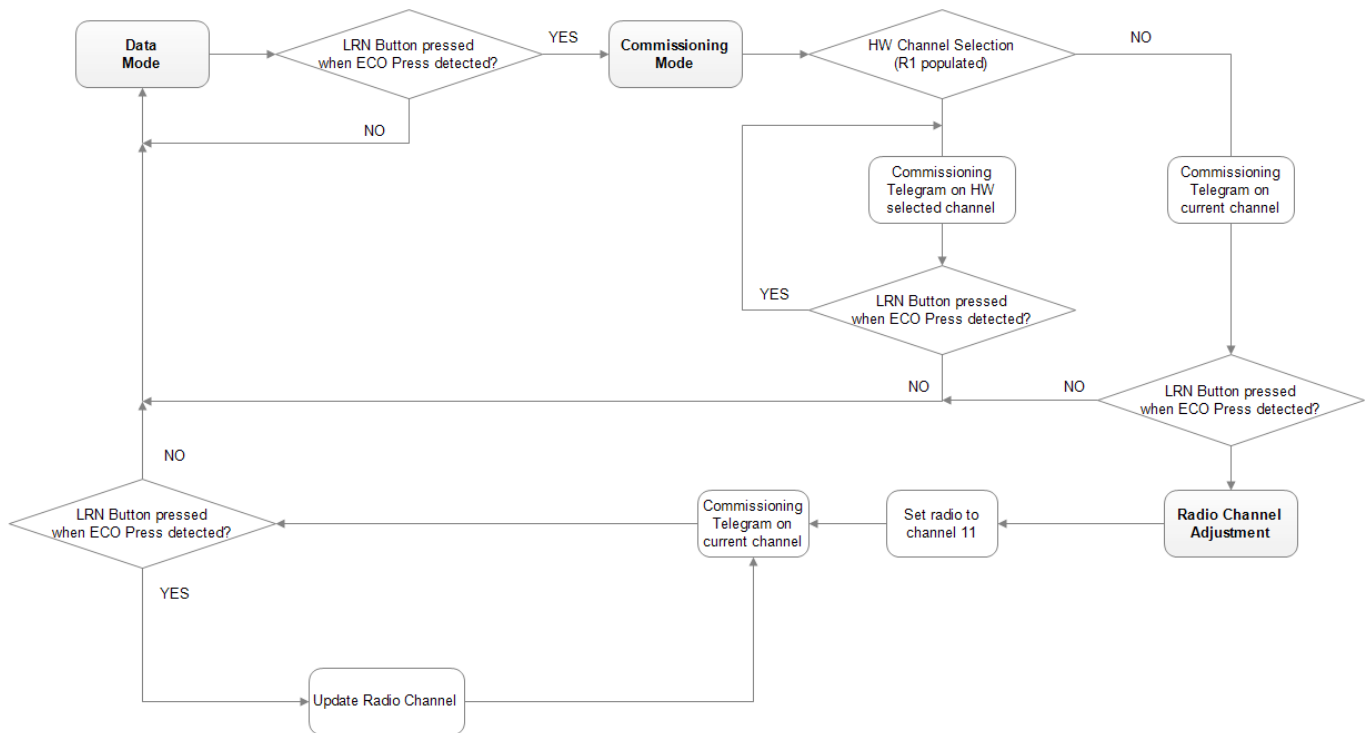

Figure 4: Commissioning state chart used by PTM 535Z

The different functions are described subsequently in more detail.

PTM 535Z – 2.4 GHz Pushbutton Transmitter

2.8.2.1 Entry into commissioning mode

Commissioning mode is entered as soon as PTM 535Z detects an energy pulse from ECO 200 or ECO 250 in "Press" direction and the LRN button is pressed. PTM 535Z will remain in commissioning mode as long as the LRN button is pressed whenever ECO 200 or ECO 250 is actuated in the "Press" direction.

2.8.2.2 Commissioning telegram

PTM 535Z will transmit a commissioning telegram on the current radio channel upon entering commissioning mode (i.e. when PTM 535Z for the first time detects an energy pulse from ECO 200 or ECO 250 in "Press" direction with the LRN button being pressed at the same time). This enables PTM 535Z to be learned into additional devices without modifying the currently used radio channel.

The type of commissioning telegram depends on whether PTM 535Z operates in secure mode or standard mode, see chapter 2.9.1. The format of the commissioning telegram is described in chapter 3.4.

2.8.2.3 Radio channel adjustment

If the HW-based channel selection is disabled (resistor R1 is not populated, default state) then PTM 535Z will enter radio channel adjustment mode if it is commissioning mode and the LRN button is pressed and ECO 200 or ECO 250 is actuated in the "Press" direction (for the second time).

PTM 535Z will then reset the radio channel to channel 11 and transmit a commissioning telegram on this radio channel. Resetting the radio channel to channel 11 ensures that the number of required LRN events for selecting a radio new channel is independent of the currently used radio channel

Each subsequent press of the LRN button together with ECO 200 or ECO 250 being actuated in the "Press" direction (3rd time ... nth time) will then cause the radio channel to be changed according to the sequence shown in Table 5 below.

Press / Release Action	1	2	3	4	5	6	7	8	9	10	11	12	13	14	15	16	17
Selected Radio Channel	Current	11	15	20	25	12	13	14	16	17	18	19	21	22	23	24	26

Table 5: Radio channel adjustment sequence

Note that PTM 535Z will select the "Primary Channels" (channels 11, 15, 20 and 25) first before selecting the remaining radio channels. Primary channels are most commonly used since they are least affected from WLAN interference.

If channel 26 has been reached, then the sequence will start again with channel 11.

2.8.2.4 Determining the correct radio channel

The user requires system feedback to determine if the correct radio channel has been reached.

Several methods are possible for that, including:

- Feedback from the device into which PTM 535Z is learned in
E.g. blinking a status light, toggling a connected load, moving a motor etc.
- Feedback from a dedicated user interface
This could for instance instruct the user on the required key sequence and confirm correct execution

It is the responsibility of the system designer to define a suitable feedback mechanism.

2.8.2.5 Storing the new radio channel and return to data mode

If PTM 535Z has been successfully set to the desired radio channel then this radio channel has to be stored and operation should return to data mode.

This is achieved by releasing the LRN button and actuating ECO 200 or ECO 250 in the "Press" direction.

2.9 Security modes

PTM 535Z can operate in two security modes:

- **Secure mode (default, R2 not populated)**
PTM 535Z operates in secure mode by default using AES128 security for data telegrams. Security is based on a random, device-unique security key which is generated during the production of the device.
- **Standard mode (if R2 is populated)**
PTM 535Z can operate in standard mode for applications requiring shorter payloads and without the need for an AES128 signature.

2.9.1 Selecting the security mode

The default operation mode is secure mode. Standard mode can be selected by populating configuration resistor R2.

2.9.2 Security parameters

PTM 535Z transmits data is secured based on a 4 byte sequence counter, an out of the box device-unique key and a 4 byte signature calculated based on the AES128 encryption using CBC mode.

The current status of the sequence counter together with the device-unique key are transmitted during commissioning and have to be stored by the device where PTM 535Z is learned in. These parameters are subsequently used to authenticate received telegrams.

EnOcean can provide references for the implementation of the required routines for key exchange and message validation upon request.

PTM 535Z – 2.4 GHz Pushbutton Transmitter

2.10 Number of redundant telegrams

For most telegram types, PTM 535Z will transmit the telegram more than once (redundant transmission) in order to increase transmission reliability. The timing of the individual telegram transmissions is random within a 5ms window.

The number of telegram transmissions is limited by the available energy and therefore dependent on the telegram length (number of bytes to be transmitted).

Typically, PTM 535Z will transmit the following number of telegrams in secure mode:

- 2 secure data telegrams
- 1 secure commissioning telegram

Standard mode telegrams are shorter because the sequence counter and the security key (commissioning telegram) / security signature (data telegram) do not need to be transmitted.

Typically, PTM 535Z will transmit the following number of telegrams in standard mode:

- 3 data telegrams
- 3 commissioning telegrams

3 IEEE 802.15.4 Frame Structure

PTM 535Z transmits radio telegrams in the 2.4 GHz band according to IEEE 802.15.4 frame structure. For detailed information about the IEEE 802.15.4 standard, please refer to the applicable specifications.

The following information about the IEEE 802.15.4 frame structure is given for reference only. Note that the data format used is little endian. This means that for multi-byte structures (such as 2 byte, 4 byte or 8 byte fields) the least significant byte (LSB) is transmitted first. The IEEE 802.15.4 frame structure used by PTM 535Z consists of the following four main parts:

■ PHY Header

The PHY header indicates to the receiver the start of a transmission and provides information about the length of the transmission.

It contains the following fields:

- Preamble
Pre-defined sequence (4 byte, value 0x00000000) used to adjust the receiver to the transmission of the sender
- Start of frame
Pre-defined symbol (1 byte, value 0xA7) identifying the start of the actual data frame
- Length
1 byte indicating the combined length of all following fields

■ MAC Header

The MAC header provides detailed information about the frame.

It contains the following fields:

- Frame control field
2 bytes to identify frame type, protocol version, addressing and security mode
- Sequence number
1 byte sequential number to identify the order of transmitted frames
- Address
PAN ID and address of source (if present) and destination of the telegram
PTM 535Z does not use source address and source PAN ID

■ MAC Payload

The MAC Payload field contains telegram control, device ID, telegram data and telegram security (if present) fields.

The MAC Payload field structure depends on telegram type (data or commissioning) and security mode (secure or non-secure transmission).

■ MAC Trailer

The MAC Trailer contains the Frame Check Sum (FCS) field used to verify the integrity of the telegram data.

PTM 535Z – 2.4 GHz Pushbutton Transmitter

Figure 5 below summarizes the IEEE 802.15.4 frame structure.

PHY Header			MAC Header			MAC Payload	MAC Trailer
Preamble	Start of Frame	Length of Frame	Frame Control	Sequence Number	DstAddress PAN Addr	Depending on Telegram Type	Frame Check Sum
4 Byte	1 Byte	1 Byte	2 Byte	1 Byte	4 Byte	Depending on Telegram Type	2 Byte

Figure 5: IEEE 802.15.4 Frame Structure

The content of these fields is described in more detail below.

3.1 PHY Header

The IEEE 802.15.4 PHY header consists of the following fields:

- Preamble
- Start of Frame
- Length of Frame fields

The content of the Preamble and Start of Frame fields is fixed for all telegram types supported by PTM 535Z as follows:

- Preamble = 0x00000000
- Start of Frame = 0xA7

The content of the Length field differs depending on the telegram type as follows:

- Secure commissioning telegram
Length= 42 bytes (0x2A)
- Secure data telegram
Length = 24 bytes (0x18)
- Standard commissioning telegram
Length = 17 bytes (0x11)
- Standard data telegram
Length = 15 bytes (0x0F)

PTM 535Z – 2.4 GHz Pushbutton Transmitter

3.2 MAC Header

The IEEE 802.15.4 MAC Header contains the following fields:

- **Frame Control Field (2 byte)**
The Frame Control Field is set to 0x0801 in all PTM 535Z telegrams in order to identify them as data telegrams with short addresses based on version IEEE 802.15.4-2003
- **Sequence Number (1 byte)**
The Sequence Number is an incremental number used to identify the order of telegrams
- **Address Field (4 byte in PTM 535Z implementation)**
PTM 535Z uses short Destination Address (16 Bit) together with the Destination PAN ID (16 Bit). Both are set to 0xFFFF to identify the telegrams as broadcast.
Source address and Source PAN ID are not present in PTM 535Z telegrams.

3.3 MAC Trailer

The MAC Trailer only contains the Frame Check Sum (FCS) field.

Its length is 2 byte and it is calculated as Cyclic Redundancy Check (CRC16) over the entire MAC payload including the "Length" field of the PHY Header using the following polynomial:
 $x^{16} + x^{12} + x^5 + 1$

3.4 MAC Payload

The MAC Payload depends on the telegram type:

- **Telegram type**
 - Data Telegram
 - Commissioning Telegram
- **Security mode**
 - Secure communication
 - Standard communication

MAC payloads for the different telegram types are described in the following chapters.

PTM 535Z – 2.4 GHz Pushbutton Transmitter

3.4.1 MAC payload structure for secure data telegrams

Figure 6 below shows the MAC Payload structure of a secure data telegram.

Telegram Control	Source ID	Sequence Counter	Command	Telegram Signature
2 Byte	4 Byte	4 Byte	1 Byte	4 Byte

Figure 6: MAC Payload structure for secure data telegrams

The following fields are used for secure data telegrams:

- Telegram Control (2 bytes)
The *Telegram Control* field is set to 0x308C indicating that PTM 535Z uses 4 byte payload signature based on a device-unique key and a 4 byte sequence counter
- Source ID (4 bytes)
The *Source ID* field contains a 4 byte ID uniquely identifying each PTM 535Z device
- Sequence Counter (4 bytes)
The *Sequence Counter* field contains an always incrementing counter. Security processing is based on the combination of the Command and Sequence Counter in order to prevent replay attacks (sending the same telegram again)
- Command (1 byte)
The *Command* field is a one byte field which identifies the state of the different inputs of PTM 535Z. For the encoding please see Table 2.
- Telegram Signature (4 byte)
The *Telegram Signature* field is used to validate the telegram authenticity. The telegram signature is calculated based on the telegram payload using AES128 (CBC mode). EnOcean can provide upon request additional information on how to implement telegram validation for PTM 535Z data telegrams.

PTM 535Z – 2.4 GHz Pushbutton Transmitter

3.4.2 MAC payload structure for secure commissioning telegrams

Figure 7 below shows the MAC payload structure of a secure commissioning telegram.

Telegram Control	Source ID	Commissioning Command	Device Type	Device Options	Device-unique Security Key	Security Key Validation	Sequence Counter
1 Byte	4 Byte	1 Byte	1 Byte	2 Byte	16 Byte	4 Byte	4 Byte

Figure 7: MAC Payload structure for secure commissioning telegrams

The following fields are used for secure commissioning telegrams:

- Telegram Control (1 byte)
The *Telegram Control* field is set to 0x0C to identify a standard telegram (secure communication will be established based on the commissioning telegram)
- Source ID (4 bytes)
The *Source ID* field contains a 4 byte ID uniquely identifying each PTM 535Z device
- Commissioning Command (1 byte)
The *Command* field is set to 0xE0 by PTM 535Z
- Device Type (1 byte)
The *Device Type* field is set to 0x02 by PTM 535Z
- Device Options (2 bytes)
The *Device Options* field is set to 0xF281 by PTM 535Z when operating in AES128 secure mode with authentication.
- Device-unique Security Key (16 bytes)
PTM 535Z implement a random, device-specific security key which is generated as part of the production flow. During commissioning, this key is transmitted in encrypted format. Contact EnOcean for details.
- Security Key Validation (4 bytes)
In order to ensure correct reception, an additional 4 byte validation value is provided. Contact EnOcean for details.
- Sequence Counter (4 bytes)
The *Sequence Counter* is an always incrementing counter which is used as part of the security processing to avoid replay attacks (sending the same telegram again). Receiving devices shall only accept data telegrams with sequence counter values higher than that of the last received telegram; therefore the current value needs to be communicated during commissioning.

PTM 535Z – 2.4 GHz Pushbutton Transmitter

3.4.3 MAC payload structure for standard data telegrams

PTM 535Z will operate in standard mode if configuration resistor R2 is populated. Figure 8 below shows the MAC payload structure of a standard data telegram.

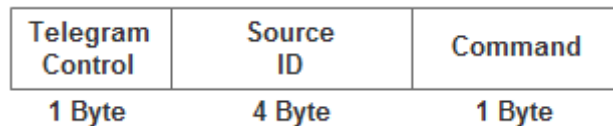

Figure 8: MAC Payload structure for Standard Data Telegrams

The following fields are used for Standard Data Telegrams:

- Telegram Control (1 byte, 0x0C)
This field is set to 0x0C to identify a standard data telegram
- Source ID (4 bytes)
4 byte ID uniquely identifying each PTM 535Z device
- Command (1 byte)
This is a one byte field which identifies the state of the different input of PTM 535Z. For the encoding please see Table 2.

3.4.4 MAC payload for standard commissioning telegrams

Figure 9 below shows the MAC payload structure of a standard commissioning telegram.

Telegram Control	Source ID	Commissioning Command	Device Type	Device Options
1 Byte	4 Byte	1 Byte	1 Byte	1 Byte

Figure 9: MAC Payload structure for standard commissioning telegrams

The following fields are used for standard commissioning telegrams:

- Telegram Control (1 byte)
The *Telegram Control* field is set to 0x0C to identify a standard telegram (secure communication will be established based on the commissioning telegram)
- Source ID (4 bytes)
The *Source ID* field contains a 4 byte ID uniquely identifying each PTM 535Z device
- Commissioning Command (1 byte)
The *Commissioning Command* field is set to 0xE0 by PTM 535Z
- Device Type (1 byte)
The *Device Type* field is set to 0x02 by PTM 535Z
- Device Options (1 byte)
The *Device Options* field is set to 0x01 by PTM 535Z

PTM 535Z – 2.4 GHz Pushbutton Transmitter

4 Device Integration

PTM 535Z is designed for integration with ECO 200 kinetic energy harvesters. EnOcean can provide mechanical reference designs upon request.

4.1 Mechanical outline

The 2D mechanical outline of PTM 535Z is shown in Figure 10 below.

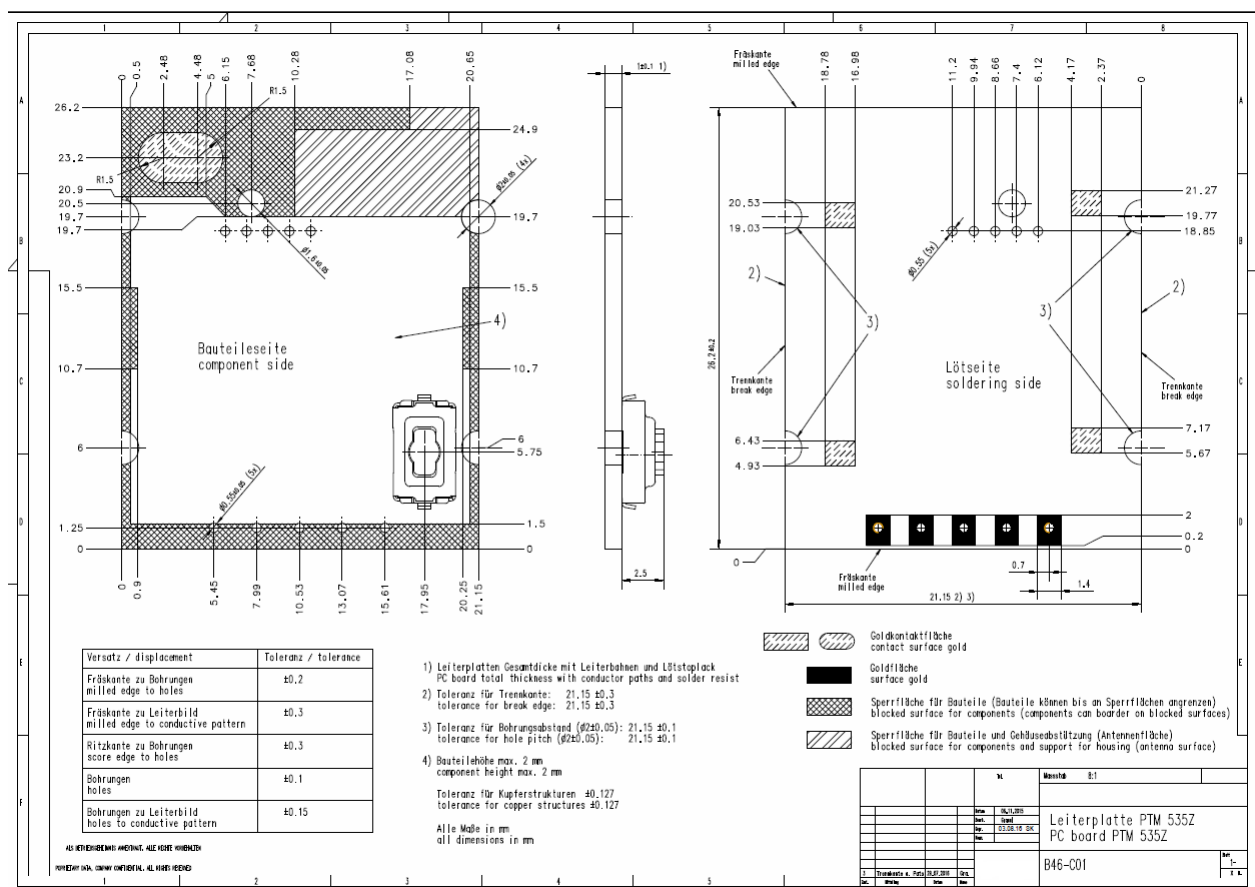

Figure 10: 2D mechanical outline of PTM 535Z

This drawing is available in higher resolution at the PTM 535Z product webpage.

PTM 535Z – 2.4 GHz Pushbutton Transmitter

The 3D mechanical outline model of PTM 535Z is available at the EnOcean PTM 535Z product webpage as IGS model. The shape of this model is shown in Figure 11 below.

The 3D profile given by this model has to be respected in custom mechanical assemblies. Any customer parts have to be placed such that they do not intrude into this 3D profile.

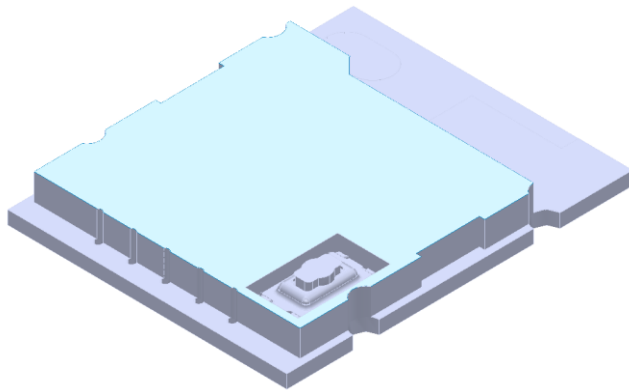

Figure 11: 3D mechanical outline of PTM 535Z

4.2 Soldering information

PTM 535Z contains five hand-solderable connection pins as described in chapter 2.3. For hand-soldering, please follow the workmanship standards according to IPC-A-610 class 2.

The following parameters have to be respected:

- Solder type: Sn60% Solder
- Soldering temperature: 350°C
- Soldering time: 3 seconds maximum
- Number of hand solderings: One time only

5 APPLICATION INFORMATION

5.1 Transmission range

The main factors that influence the system transmission range are:

- Type and location of the antennas of receiver and transmitter
- Type of terrain and degree of obstruction of the link path
- Sources of interference affecting the receiver
- "Dead spots" caused by signal reflections from nearby conductive objects.

Since the expected transmission range strongly depends on this system conditions, range tests should always be performed to determine the reliably achievable range under the given conditions.

The following figures should be treated as a rough guide only:

- Line-of-sight connections
Typically 15 m range in corridors, up to 50 m in halls
- Plasterboard walls / dry wood
Typically 15 m range, through max. 2 walls
- Ferro concrete walls / ceilings
Maximum 1 wall or ceiling, depending on thickness and material
- Fire-safety walls, elevator shafts, staircases and similar areas should be considered as shielded

The angle at which the transmitted signal hits the wall is very important. The effective wall thickness – and with it the signal attenuation – varies according to this angle. Signals should be transmitted as directly as possible through the wall. Wall niches should be avoided.

Other factors restricting transmission range include:

- Switch mounting on metal surfaces (up to 30% loss of transmission range)
- Hollow lightweight walls filled with insulating wool on metal foil
- False ceilings with panels of metal or carbon fibre
- Lead glass or glass with metal coating, steel furniture

The distance between the receiver and other transmitting devices such as computers, audio and video equipment that also emit high-frequency signals should be at least 0.5 m.

5.2 Duty Cycle

PTM 535Z is designed for manually activated systems. In order to comply with duty cycle limitations, it shall not be used to transmit telegrams more often than 10.000 times per hour.

PTM 535Z – 2.4 GHz Pushbutton Transmitter

5.3 Device PCB label

PTM 535Z contains a PCB label with the regulatory information as shown in Figure 12 below.



Figure 12: PTM 535Z PCB Label

This label contains the following fields:

Field	Content	Description
1	MODEL: PTM 535Z xy A535-z mm/jj	Step Code „xy” (e.g. DA) Internal revision „-z” (e.g. -1); Date Code “mm/jj” (e.g. 32/16)
2	 003-160253	ARIB Sign and ID (e.g. 003-160253)
3	IC:5713A-PTM535Z	ISED (Industry Canada) certification ID
4	FCC ID: SZV-PTM535Z	FCC certification ID

6 REGULATORY INFORMATION

PTM 535Z has been certified according to applicable regulations.

Changes or modifications not expressly approved by EnOcean could void the user's authority to operate the equipment.

6.1 FCC (United States) Certification

PTM 535Z has been certified according to FCC rules.

6.1.1 FCC (United States) Labeling Requirements

The Original Equipment Manufacturer (OEM) must ensure that FCC labeling requirements are met. This includes a clearly visible label on the outside of the final product. Attaching a label to a removable portion of the final product, such as a battery cover, is not permitted.

The label must include the following text:

PTM 535Z Contains FCC ID: SZV-PTM535Z

The enclosed device complies with Part 15 of the FCC Rules. Operation is subject to the following two conditions: (i.) this device may not cause harmful interference and (ii.) this device must accept any interference received, including interference that may cause undesired operation.

When the device is so small or for such use that it is not practicable to place the statement above on it, the information required by this paragraph shall be placed in a prominent location in the instruction manual or pamphlet supplied to the user or, alternatively, shall be placed on the container in which the device is marketed.

However, the FCC identifier or the unique identifier, as appropriate, must be displayed on the device.

PTM 535Z – 2.4 GHz Pushbutton Transmitter

6.1.2 FCC (United States) Certificate

TCB

**GRANT OF EQUIPMENT
AUTHORIZATION**

TCB

**Certification
Issued Under the Authority of the
Federal Communications Commission
By:**

**EMCCert Dr, Rasek GmbH
Stoernhofer Berg 15
91364 Unterleinleiter,
Germany**

**Date of Grant: 06/15/2016
Application Dated: 06/15/2016**

**EnOcean GmbH
Kolpingring 18a
Oberhaching, 82041
Germany**

Attention: Armin Anders , Director Product Marketing

NOT TRANSFERABLE

EQUIPMENT AUTHORIZATION is hereby issued to the named GRANTEE, and is VALID ONLY for the equipment identified hereon for use under the Commission's Rules and Regulations listed below.

FCC IDENTIFIER: SZV-PTM535Z
Name of Grantee: EnOcean GmbH
Equipment Class: Part 15 Low Power Communication Device Transmitter
Notes: 2405 MHz - 2480 MHz transmitter
Modular Type: Limited Single Modular

<u>Grant Notes</u>	<u>FCC Rule Parts</u>	<u>Frequency Range (MHZ)</u>	<u>Output Watts</u>	<u>Frequency Tolerance</u>	<u>Emission Designator</u>
	15C	2405.0 - 2480.0			

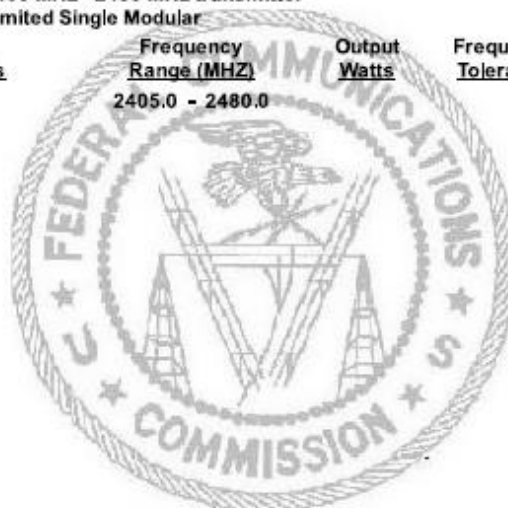

6.1.3 FCC (United States) Regulatory Statement

This device complies with part 15 of the FCC Rules.

Operation is subject to the following two conditions:

- (1) this device may not cause harmful interference, and
- (2) this device must accept any interference received, including interference that may cause undesired operation.

PTM 535Z – 2.4 GHz Pushbutton Transmitter

6.2 IC (Industry Canada) Certification

PTM 535Z has been certified according to IC rules.

6.2.1 IC (Industry Canada) Labeling Requirements

OEM wishing to use PTM 535Z under limited modular approval conditions must sign the OEM Limited Modular Approval Agreement with EnOcean

The Original Equipment Manufacturer (OEM) must ensure that IC labeling requirements are met. Labelling requirements for Industry Canada are similar to those required by the FCC.

This includes a clearly visible label on the outside of the final product. Attaching a label to a removable portion of the final product, such as a battery cover, is not permitted. The label must include the following text:

Contains IC: 5713A-PTM535Z

Pour utiliser le numéro IC EnOcean, le fabricant d'équipement d'origine (OEM) doit signer l'accord OEM limitée Approbation modulaire avec EnOcean et doit s'assurer que les exigences en matière d'étiquetage IC sont réunies.

Une étiquette clairement visible à l'extérieur d'une partie non amovible du produit final doit contenir le texte suivant:

Contient le module d'émission IC: 5713A-PTM535Z

PTM 535Z – 2.4 GHz Pushbutton Transmitter

6.2.2 IC (Industry Canada) Certificate



FCB under the Canada-EC MRA
 TCB under the USA-EC MRA
 RFCAB under the Japan-EC MRA
 Notified Body RTTE Directive 99/5/EC
 Notified Body EMC Directive 2014/30/EU

No. CA001676G

**TECHNICAL ACCEPTANCE
 CERTIFICATE
 CANADA**

**CERTIFICAT D'ACCEPTABILITÉ
 TECHNIQUE
 CANADA**

CERTIFICATION No. ► 5713A-PTM535Z
 No. DE CERTIFICATION
 ISSUED TO ► EnOcean GmbH
 DELIVRE A

Street Address Kolpingring 18 a
 Numéro et rue
 Province or State Germany
 Province ou Etat

City Oberhaching
 Ville
 Postal Code S2041
 Code postal

TYPE OF EQUIPMENT ► Low Power Device (2400–2483.5 MHz), Modular
 GENRE DE MATERIEL Approval

PMN ► PTM 535Z
 HVIN ► PTM 535Z

ANTENNA ► Integrated
 ANTENNE Incorporé

ANTENNA GAIN ►
 GAIN D'ANTENNE

FREQUENCY RANGE BANDE DE FRÉQUENCES	EMISSION TYPE GENRE D'ÉMISSION	RF POWER PUISSANCE H.F.	SPECIFICATION / ISSUE / DATE SPÉCIFICATION / ÉDITION / DATE
2405 - 2480 MHz	2M40G1D	95.8 dBµV/m	RSS-210 / 8 / December 2010

TEST LABORATORY ► EMCCons DR. RAŠEK GmbH & Co. KG
 LABORATOIRE D'ESSAY

Street Address Stoernhofer Berg 15
 Numéro et rue
 Province or State Germany
 Province ou Etat
 Name Patrick Reusch
 Nom
 E-mail p.reusch@emcc.de

CN 3464C OATS 3464C-1
 City Unterleinleiter
 Ville
 Postal Code 91364
 Code Postal
 Tel 0049 9194 7262-0
 Fax 0049 9194 7262-199

Certification of equipment means only that the equipment has met the requirements of the above-noted specification. Licence applications, where applicable to use certified equipment, are acted on accordingly by the Industry Canada issuing office and will depend on the existing radio environment, service and location of operation. This certificate is issued on condition that the holder complies and will continue to comply with the requirements and procedures issued by Industry Canada. The equipment for which this certificate is issued shall not be manufactured, imported, distributed, leased, offered for sale or sold unless the equipment complies with the applicable technical specifications and procedures issued by Industry Canada.

La certification du matériel signifie seulement que le matériel a satisfait aux exigences de la norme indiquée ci-dessus. Les demandes de licences nécessaires pour l'utilisation du matériel certifié sont traitées en conséquence par le bureau de délivrance d'Industrie Canada et dépendent des conditions radio ambiantes, du service et de l'emplacement d'exploitation. Le présent certificat est délivré à la condition que le titulaire satisfasse et continue de satisfaire aux exigences et aux procédures d'Industrie Canada. Le matériel à l'égard duquel le présent certificat est délivré ne doit pas être fabriqué, importé, distribué, loué, mis en vente ou vendu à moins d'être conforme aux procédures et aux spécifications techniques applicables publiées par Industrie Canada.

I hereby attest that the subject equipment was tested and found in compliance with the above-noted specification.

J'atteste par la présente que le matériel a fait l'objet d'essai et jugé conforme à la spécification ci-dessus.

DATE 16 June 2016



Certification Officer

6.2.3 IC (Industry Canada) Regulatory Statement

This device complies with Industry Canada licence-exempt RSS standard(s).

The end product into which PTM 535Z is assembled must provide a clearly readable label with the following text: „Contains IC ID: SZV-PTM535Z“

Operation is subject to the following two conditions:

- (1) this device may not cause interference, and
- (2) this device must accept any interference, including interference that may cause undesired operation of the device.

Le présent appareil est conforme aux CNR d'Industrie Canada applicables aux appareils radio exempts de licence.

L'exploitation est autorisée aux deux conditions suivantes :

- (1) l'appareil ne doit pas produire de brouillage, et
- (2) l'utilisateur de l'appareil doit accepter tout brouillage radioélectrique subi, même si le brouillage est susceptible d'en compromettre le fonctionnement.”

PTM 535Z – 2.4 GHz Pushbutton Transmitter

6.3 ARIB (Japan) Certification

PTM 535Z has been certified for use in Japan according to ARIB (Association of Radio Industries and Businesses) rules.

6.3.1 ARIB (Japan) Certificate

認 証 書

認証を受けた者	株式会社ルネサスイーストン
特定無線設備の種別	第2条第1項第19号に掲げる無線設備 2.4GHz帯高度化小電力データ通信システム
電波の形式、 周波数及び 空中線電力	G1D 2405～2480MHz(5MHz間隔16波) 0.00135W/MHz
型式又は名称	PTM_535Z
販売業者	株式会社ルネサスイーストン
認証番号	003-160253
認証をした年月日	2016年11月21日
備考	No.16-1915

上記のとおり、電波法第38条の24第1項の規定に基づく認証を行ったものであることを証する。

2016年11月21日

株式会社ディーエスピーリサーチ



PTM 535Z – 2.4 GHz Pushbutton Transmitter

A Understanding PTM 535Z telegram structure

This appendix describes – purely for reference purposes – how to analyse the PTM 535Z radio telegram structure using the TI CC2531EMK packet sniffer (USB dongle) on a Windows 7 based system.

A.1 Installation instructions for TI CC2531 packet sniffer

The following description assumes the use of the TI CC2531EMK described here:

<http://www.ti.com/tool/cc2531emk>

CC2531EMK can be used in conjunction with the “TI SmartRF Protocol Packet Sniffer” to capture and visualize IEEE 802.15.4 data telegrams.

To use TI SmartRF Protocol Packet Sniffer, please download the SW package from the TI website. At the time of writing, the SW could be obtained using this link:

<http://www.ti.com/tool/packet-sniffer>

Please download and install this SW before proceeding with the instructions given in the next chapter.

A.1.1 CC2531EMK setup

After setting up the TI SmartRF Protocol Packet Sniffer please insert the CC2531EMK USB dongle into a USB port of the PC and make sure that the green LED of the dongle is active.

Please make sure that the required device driver for the CC2531EMK has been correctly installed. To do so, please check the Device Manager where you should see an entry named “CC2531 USB Dongle” under the group label “CEBAL Controlled Devices”.

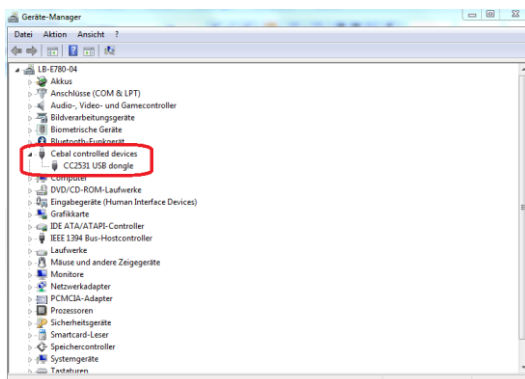

Figure 13 – Correctly installed CC2531EMK

PTM 535Z – 2.4 GHz Pushbutton Transmitter

A.2 Configuration

After the installation of the CC2531EMK driver, please start the TI SmartRF Packet Sniffer program. The protocol selection dialog program window which appears after the start of is shown in Figure 14 below.

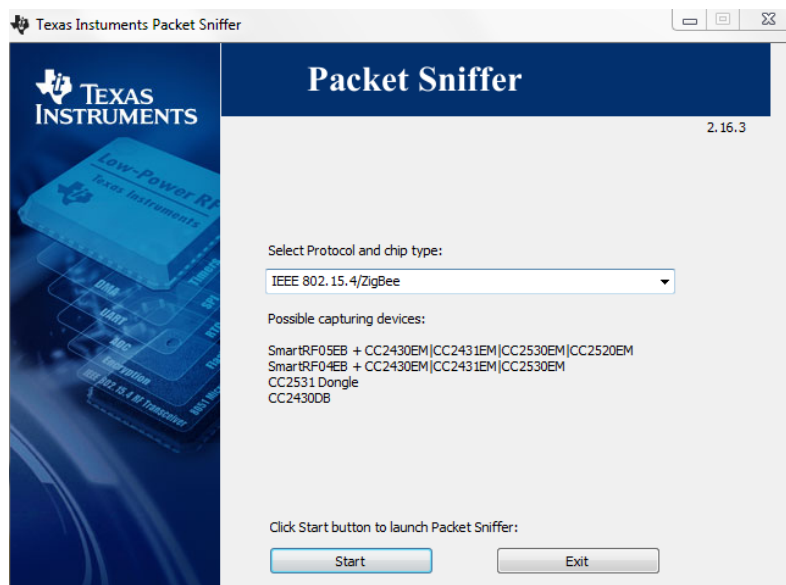

Figure 14 – Protocol selection dialog of TI SmartRF Packet Sniffer

In this dialog, please select “IEEE 802.15.4/ZigBee” as shown above and press the “Start” button. Once the main window comes up, please make sure that “CC2531” is shown in the “Capturing device” tab and in the “RF device:” footer line as shown in Figure 15 below.

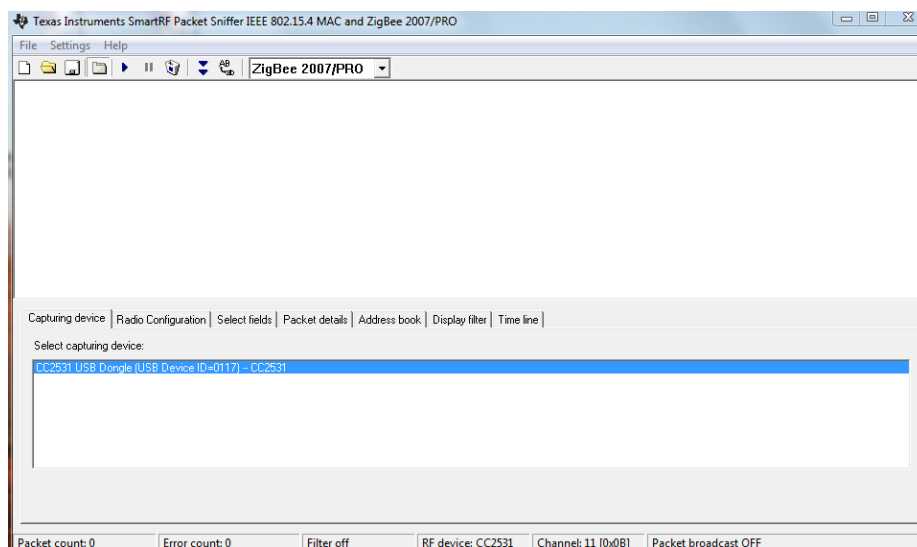

Figure 15 – Main window TI SmartRF Packet Sniffer

PTM 535Z – 2.4 GHz Pushbutton Transmitter

Out of the box, PTM 535Z is configured for using IEEE 802.15.4 radio channel 11. Make sure that this radio channel (0x0B) is selected in the “Radio Configuration” tab and shown in the “Channel:” footer line.

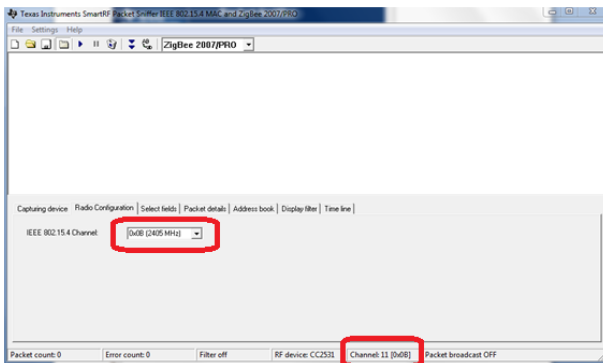

Figure 16 – Radio channel selection

The data fields that will be displayed can be selected in the “Select fields” tab. Make sure that all “MAC Header”, “Data” and “Footer” fields are selected and that the “LQI/RSSI” drop-down list is set to “RSSI”.

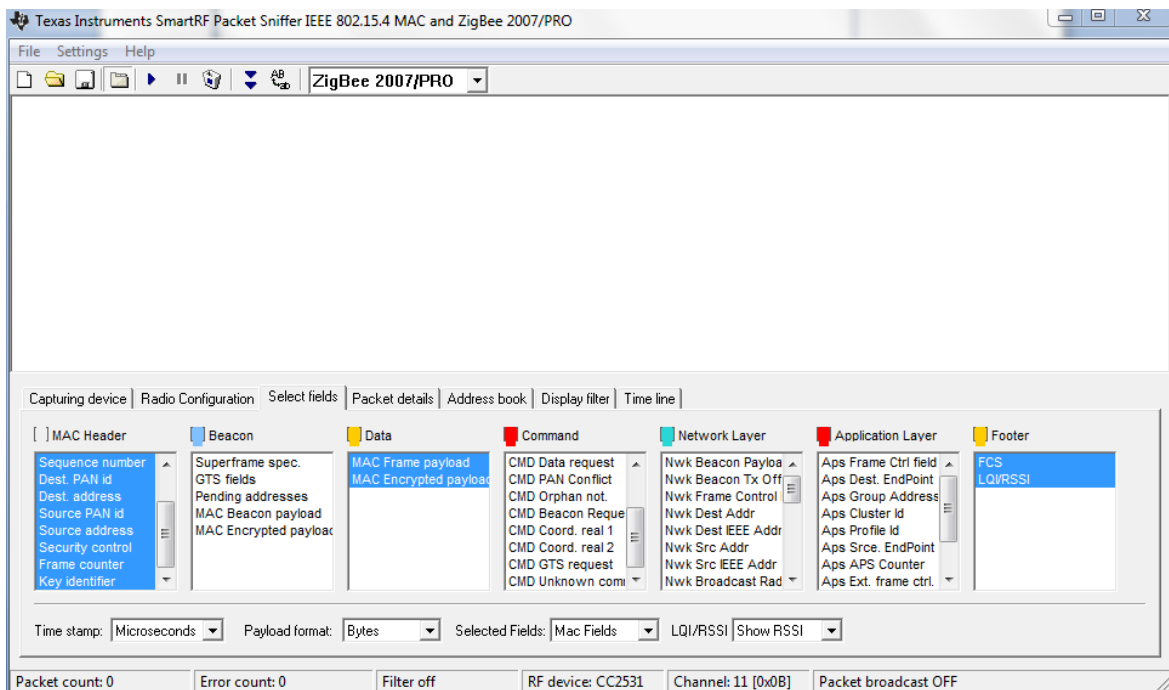

Figure 17 – Payload selection

The TI SmartRF Packet Sniffer is now ready.

PTM 535Z – 2.4 GHz Pushbutton Transmitter

A.3 Data capture

Press the triangular button (▶) to start the radio capture and press the auto-scroll button (⏮) to automatically select the most recent data telegram. Then press a button of PTM 535Z.

You should now see the captured radio telegrams (PTM 535Z sends several redundant radio telegrams per user action).

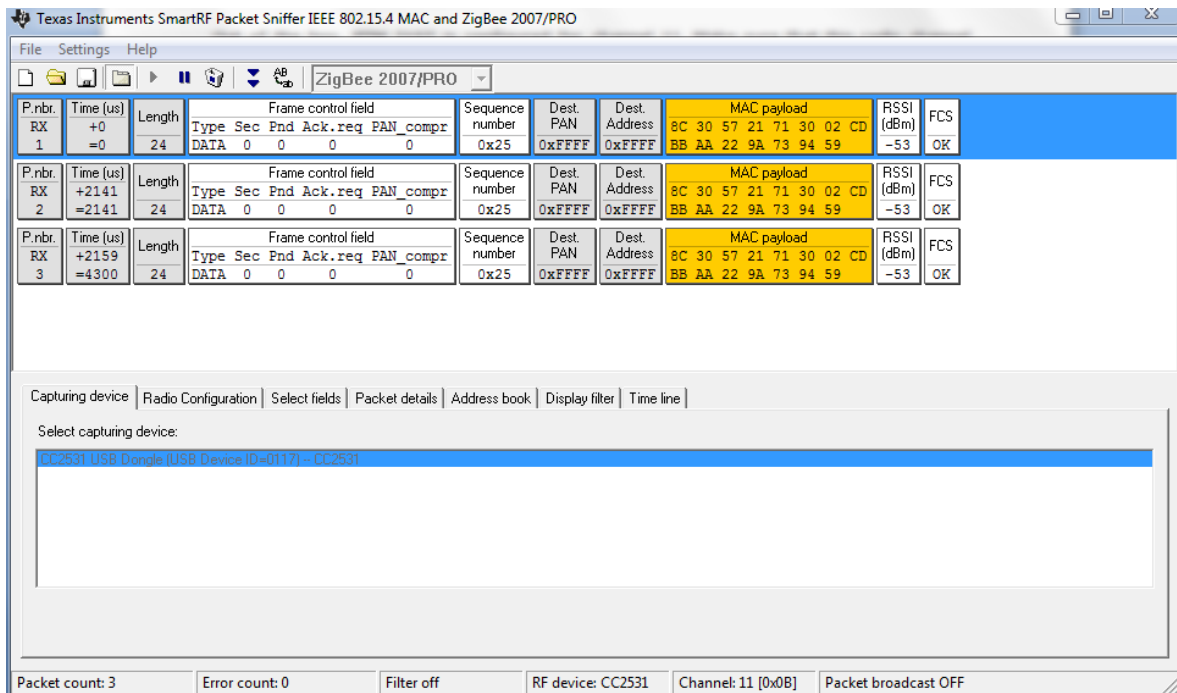

Figure 18 – Captured telegram data

PTM 535Z – 2.4 GHz Pushbutton Transmitter

A.4 Interpretation of the telegram data

The following parameters within captured radio telegrams are typically of interest:

1. MAC Payload
This will contain the ID of the sender, various control and security data fields as well as the actual command data (1 byte)
The structure of this field is outlined subsequently in more detail.
2. RSSI
This will show the received signal strength
3. FCS
This will show the frame integrity (OK / not OK) and should normally show "OK".

A.4.1 MAC Payload

Below is an example of a captured MAC payload for a secure data telegram (see chapter 3.4.1):

MAC payload							
8C	30	57	21	71	30	04	CD
BB	AA	22	84	D1	99	78	

The hexadecimal representation of this specific payload is:

8C 30 57 21 71 30 04 CD BB AA 22 84 D1 99 78

The location and interpretation of key parameters is described in the following chapters.

A.4.2 Device ID

The 4 byte device ID is used to uniquely identify each device in the network. In the case of secure data telegrams it is located at byte 2...5 of the MAC payload as highlighted below:

8C 30 **57 21 71 30** 04 CD BB AA 22 84 D1 99 78

Keep in mind that the byte order is little endian, therefore the ID of this specific device is 0x30712157.

A.4.3 Sequence Counter

The sequence counter is used to uniquely identify each telegram in order to avoid telegram replay. The sequence counter is 4 byte long and only present if PTM 535Z operates in secure mode.

In the case of a secure data telegram, the sequence counter is located at byte 6...9 of the MAC payload as highlighted below:

8C 30 57 21 71 30 **04 CD BB AA** 22 84 D1 99 78

Keep in mind that the byte order is little endian, therefore the current sequence counter value of this specific device is 0xAABBCD04.

PTM 535Z – 2.4 GHz Pushbutton Transmitter

A.4.4 Command payload

The command payload identifies the action performed on the switch (i.e. which buttons have been pressed). In the case of a secure data telegram, the command is located at byte 10 of the MAC payload as highlighted below:

```
8C 30 57 21 71 30 04 CD BB AA 22 84 D1 99 78
```

In this case it is 0x22 meaning that button A0 has been pressed. Refer to chapter 2.5.1 for the description of commands supported by PTM 535Z.

A.4.5 Telegram Signature

PTM 535Z secure data telegrams can be authenticated via a signature.

This signature is 4 byte long and only present if PTM 535Z operates in secure mode. It is calculated based on the private key (unique for each device), the data payload and a 4 byte sequence counter (which is incremented for each transmitted radio telegram).

This approach prevents unauthorized senders from sending commands. Note that the content of the telegram itself is not encrypted, i.e. the switch command is sent as plain text.

In the case of a secure data telegram, the telegram signature is located at the last 4 bytes of the telegram payload:

```
8C 30 57 21 71 30 04 CD BB AA 22 84 D1 99 78
```

Note that the signature changes with each transmission even if the remainder of the MAC payload remains the same.

This is due to the inclusion of the rolling code into the MIC calculation which prevents message replay attacks (capture and reuse of a previous message).