

Installation Guide

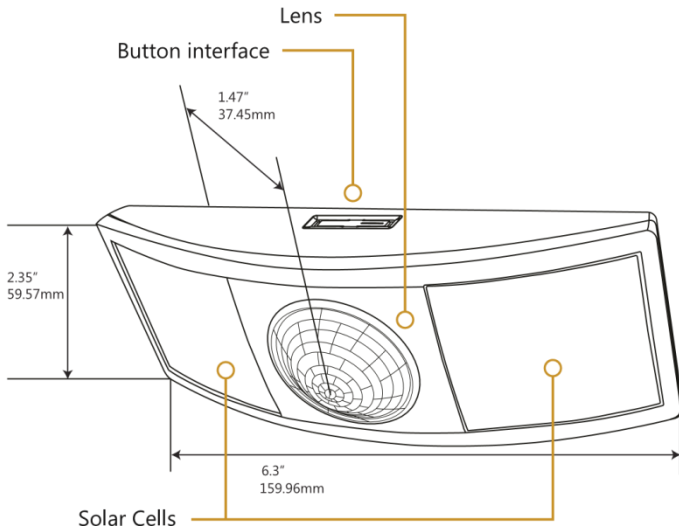

Package Content

- PIR Sensor
- Mounting plate for easy mounting at ceiling with double-sided adhesive tape (included)
- Securely secure the device with screws (not included)

Product Description

This ceiling mounted sensor is detecting people motion activity in the sensing range underneath the sensor. The device is wireless and solar-powered, so no batteries are needed under typical light conditions and easiest to mount also in retrofitting.

The unit uses a passive infrared (PIR) sensor technology that permanently records the people activity. After a certain time the number of recorded motion activities (counter value) is transmitted via a radio signal to an IoT space utilization system.

Functional Description

The PIR sensor is permanently active. If any motion is detected within a 1 second measurement cycle time the activity counter is incremented by 1. If any motion has been detected within a 2 minutes transmission cycle time a radio telegram is send with the latest counter value indicating how many increments (motions) have been detected within the latest 2 minutes. If no motion has been detected during the latest 60 minutes an unoccupied message is send (heartbeat signal). The activity counter value is 16 bit and will not be reset after transmission.

Typical Applications

A people heat-map can easily be generated using several EPAC sensors in a building area and visualizing the count data in a floor plan by an IoT space utilization system. The number of people (people count) should be derivable from the count data using suited IoT analytics software (not provided with this sensor).

Note: To restrict the coverage area (e.g. for detecting the length of a people cue), suitable lens covers can be made by 3D printing (see sensor sensing range).

Specifications (typ. values)

EnOcean Equipment Profile	D2-15-00
Power Supply: Optional:	Indoor light energy harvesting. Supplemental battery (CR2032) or external power (3-5 VDC, 2-wire)
RF Transmission Range	25 m (80 ft.)
Motion Sensing Range	10 m (34 ft.) diameter (refer to coverage diagrams)
Startup Charge Times*: • First radio transmission • Light Test / Walk Test	(operation from empty energy store) 5 minutes @ 200 lux (linking) 1.5 hours @ 2000 lux
Time to Full Charge*	25 hours @ 200 lux
Life time in total darkness	72 hours (after full charge, no activity, and break-in of several days)
Sustaining charge time for battery free operation**	8 hours per 24 hours @ 100 lux
Optional Battery Life**: • Infrequent Bright Light • Consistent Low Light • Total Darkness	CR2032, min. 230 mAh 15 yrs (with 200 lux for 2 hrs/day, 7 days/week) 10 yrs (with 70 lux for 5 hrs/day, 7 days/week) 5 yrs
Measurement cycle time	0.9 seconds +/- 10%
Transmission cycle time	2 minutes +/- 10% (counter value = number of activities detected)
Heartbeat Transmission Interval (unoccupied)	60 minutes +/- 10% (no activity, counter value NOT changed)
RF Communications	EnOcean 868 MHz (EPACA) EnOcean 902 MHz (EPACU)
Dimensions (L x W x D)	160mm x 60mm x 37mm (6.30" x 2.35" x 1.47")
Weight	125 g (4.4 oz.)
Mounting Height	2-3 m (7-10 ft.) recommended
Environment	Indoor use only! 20% to 95% relative humidity (non-condensing). Operation 5°...30°C (41° to 86°F), Storage -10°...+40°C (14° to 104°F).
Agency Compliance	RoHS, CE, RE-D

Installation Guide

* No activity (or lens covered). Natural bright light (2000 lux) or a battery can be temporarily used to shorten startup charge time significantly. Specified lux values are for typical fluorescent lighting. Lux level requirements for LED and other types may vary.

** On average 8h a day permanent activity, 16h a day no activity

1 Planning

Take a moment to plan for the sensor's successful operation and optimal communication with the other system components:

- Remove the sensor from its packaging and place it under a bright light to provide the required startup charge. Optionally, to ensure the sensor energy storage is fully charged, insert a CR2032 battery for 5 minutes while in a well-lit location.
- Ensure the location provides consistent and adequate light. **Mounting next to ceiling lights is recommended!** For places with little or no daylight, this is mandatory or you have to use a supplemental battery.
- Locate the sensor between 2 to 3 m high (7-10 ft)
- Provide a minimum distance of 1.5 m (4 ft) away from heat sources as light bulbs, forced air, or ventilation systems. Avoid installed near ceiling fan or hanging light fixtures.
- Consider the construction materials (such as metal) in the space and obstacles that may interfere with RF signals.

Sensor Sensing Range

10 m (34 ft.) diameter, refer to coverage diagram.

To restrict the coverage area, **suitable lens covers can be made by 3D printing**. Corresponding instructions and design data are available from EnOcean as application note AN 701.

Coverage Diagram

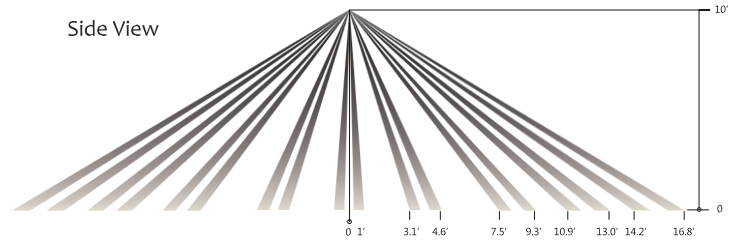
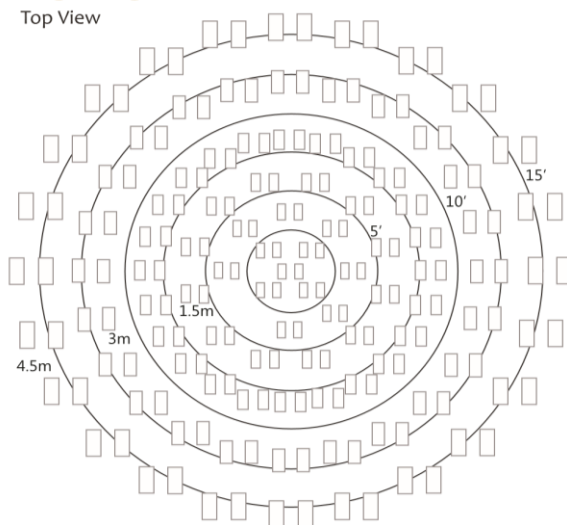

2 Installing

estimated time: 5 minutes



The sensor can be mounted at most ceilings with a suited double sided adhesive. If needed, screws can also be used to fix the mounting plate.

NOTE: Sometimes it's easier to link the sensor before it is mounted on the ceiling. Refer to the "Linking" section.

1. Remove the sensor from packaging and remove the mounting plate from the sensor.
2. Define where you want to install the occupancy sensor (see "Planning") and fix the mounting plate (gluing or screwing).
3. Attach the sensor to the mounting plate: Slide the sensor on the mounting plate until it snaps into place.
4. Confirm the sensor is properly positioned to detect motion and has sufficient light to operate - refer to the "Walk Test" and "Light Test" sections

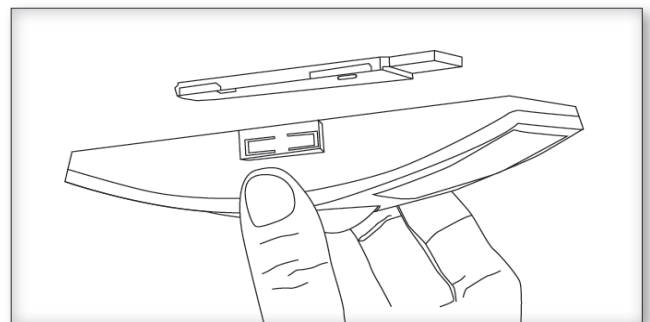

3 Linking

Linking is the process by which different devices are configured to work with each other in a system. Sometimes this process is also called Teach-in or Learn-in. During Linking, the sensor has to communicate its unique device address and the profile that it uses to the receiver that will receive and react to telegrams from the sensor. This information is available either from the device label (QR code) or can be communicated via a dedicated telegram (a so-called teach-in telegram).

To Link or Unlink the sensor

1. Set the desired receiver of the sensor telegram to Link or Unlink mode (refer to the receiver device's installation guide).
2. Click the Menu button on the bottom of the sensor once. This sends a link/unlink radio telegram.

NOTE: The button interface on the sensor is used for linking and testing only. Refer to the "Linking" section of the receiver installation guide to complete the linking & setup process.

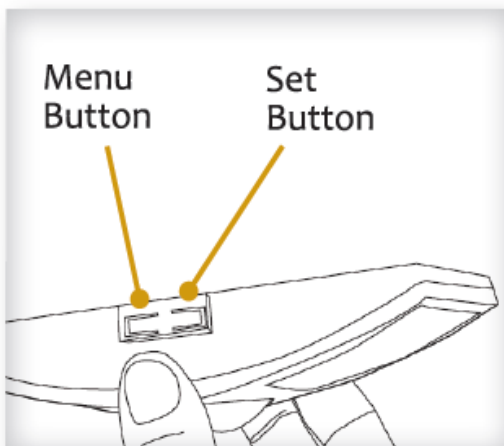

4 Walk Test

Use the walk test to confirm that motion is within the sensor's range.

NOTE: Before starting the test, ensure the battery is inserted for 5 minutes at least. If the sensor does not have a sufficient power, it cannot enter into the test mode. No LED light or 1 red blink when the set button is pressed indicates insufficient power.

1. Press and hold the Set button for 5 seconds.
 - > Red LED will blink to confirm that a walk test is active.
2. Move in and out of the sensor's range to determine its coverage area.
 - > Sensor will blink when it detects motion.
3. Make small hand movements just inside the limit of the sensor's range to see if the motion triggers a response.
4. The test mode will stay active for 3 minutes. To exit the test before and resume normal operation, press and hold the Menu button for 5 seconds.

NOTE: Ensure the sensor does not falsely trigger from user activity outside the desired zone or other heat and motion sources. If false triggering occurs, adjust the sensitivity switch (next to the battery slot) from REG to LOW.

5 Light Test

Use the light test to measure real-time light levels and confirm whether the occupancy sensor has sufficient light.

1. Create a realistic lighting condition (the test measures the real-time light level).
2. Press and hold the Set button for 10 seconds.
 - > Red & green LEDs will blink to confirm light test is active.
3. Watch the LED blink rate to determine the light strength.
 - > The highest is 5 blinks which indicate very good light (200 lux or more). 2 blinks indicate minimum light (50 lux).

NOTE: If there is one or no blink rate, consider relocating the sensor or installing a battery to provide supplemental power.

6 Supplemental Power Supply (optional)

If needed, an auxiliary 3-5 VDC power source can be used:

1. Remove the sensor from the mounting plate and identify the auxiliary power connector on the circuit board.
2. Insert the + and - leads of a 3-5 VDC external power supply into the appropriate 2 wire screw terminals.
3. Remount the sensor on the mounting plate

7 Safety Instructions

Intended use:

This product is intended for indoor usage in closed dry rooms. The product must not be used in any relation with equipment that supports, directly or indirectly, human/animal health or life or with applications that can result in danger for people, animals or real value. The product is not suitable for use in mechanically or environmentally challenging environments including (but not limited to) environments with heavy vibrations, mechanical shocks, very high humidity, very dusty or in explosive atmosphere. The installation and assembly of electrical equipment may only be performed by a skilled electrician.

Basic safety instructions:

Risk of suffocation! Do not leave the packaging material lying around. Children could swallow the small parts and choke on them. Install and operate product according to user manual and do not modify product. The product should not be exposed to rapid temperature changes shortly before or during operation; condensation of moisture has to be avoided. Wrong cleaning may damage the product; we suggest cleaning with soft and damp tissue.

Disposal:

Product: Dispose of the used components at an official collection point for electronic waste or at your local dealer.
 Packing: Please use the recycling operators known to you.
 Germany: WEEE-Reg.-No.: DE 93770561

8 Troubleshooting

Problem	Solution Checklist
Sensor does not generate a wireless message	<ul style="list-style-type: none"> ▪ Press Set button to transmit motion message ▪ Verify the LED blinks when motion is detected during a walk test ▪ Insert a battery and test again
Sensor is activated when there is nothing to detect	<ul style="list-style-type: none"> ▪ Verify there is 1.5 m (4 ft.) clearance from heat sources that may disturb sensing ▪ Reduce sensitivity setting by moving the PIR sensitivity switch on the back from REG to LOW (the left-hand position)
Linked device does not respond to wireless messages	<ul style="list-style-type: none"> ▪ Force motion message by pressing Set button ▪ Check for environment or range issues ▪ Verify the device is linked ▪ Check the transceiver connection and the wiring for errors ▪ Check if appropriate devices are linked according to good system planning

9 Agency compliance



868,300 MHz: contains: RE-D, RoHS, REACH



902 MHz: contains:

FCC: SZV-STM300U
 IC: 5713A-STM300U

This device complies with part 15 of the FCC rules and Industry Canada ICES-003. Operation is subject to the following two conditions: (1) This device may not cause harmful interference, and (2) this device must accept any interference received, including interference that may cause undesired operation.

IMPORTANT! Any changes or modifications not expressly approved by the party responsible for compliance could void the user's authority to operate this equipment.



WEEE-Reg.-No.: DE 93770561

EnOcean GmbH
 Kolpingring 18a
 82041 Oberhaching
 Germany