

ETHSA / ETHSU
ENOCEAN TEMPERATURE AND HUMIDITY SENSOR

ETHSA / ETHSU
EnOcean Temperature and Humidity Sensor

(Stepcode DE and later)



Observe precautions! Electrostatic sensitive devices!

Patent protected:

WO98/36395, DE 100 25 561, DE 101 50 128,
WO 2004/051591, DE 103 01 678 A1, DE 10309334,
WO 04/109236, WO 05/096482, WO 02/095707,
US 6,747,573, US 7,019,241

ETHSA / ETHSU ENOCEAN TEMPERATURE AND HUMIDITY SENSOR

REVISION HISTORY

The following major modifications and improvements have been made to this document:

Version	Author	Reviewer	Date	Major Changes
1.0	MKA	MKA	22.12.2017	First release (902 MHz Version)
1.1	AA	MKA	26.02.2018	Several additions: 868 MHz version, enhanced security feature, packaging info, outline drawings, application info, etc...
1.2	AA	AA	28.05.2018	Chapter 4.3 added (Installing Supplemental Battery)
2.0	AA	AA	04.01.2019	Additional supplied Wall Mounting Plate added (in chapters 2.1, 2.5, 2.6)
2.1	AA	AA	01.02.2019	Tray packaging added (chapter 2.4, new chapter 2.7)
3.0	AA	MK	18.11.2019	New Step Code DE: Update with long-term energy storage replacement, additional transport mode for longer shelf storage & air cargo, optimized Secure Mode. Adding information about QR Code. Update of Regulatory Notes inclusive European waste treatment.
3.1	MK		11.4.2022	UK market approval and UKCA added

**Published by EnOcean GmbH, Kolpingring 18a, 82041 Oberhaching, Germany
www.enocean.com, info@enocean.com, phone +49 (89) 6734 6890**

© EnOcean GmbH, All Rights Reserved

Other trademarks and trade names are those of their respective owners.

Important!

This information describes the type of component and shall not be considered as assured characteristics. No responsibility is assumed for possible omissions or inaccuracies. Circuitry and specifications are subject to change without notice. For the latest product specifications, refer to the EnOcean website: <http://www.enocean.com>.

As far as patents or other rights of third parties are concerned, liability is only assumed for modules, not for the described applications, processes and circuits. EnOcean does not assume responsibility for use of modules described and limits its liability to the replacement of modules determined to be defective due to workmanship. Devices or systems containing RF components must meet the essential requirements of the local legal authorities. The modules must not be used in any relation with equipment that supports, directly or indirectly, human health or life or with applications that can result in danger for people, animals or real value. Components of the modules are considered and should be disposed of as hazardous waste. Local government regulations are to be observed. Packing: Please use the recycling operators known to you.

TABLE OF CONTENT

- 1 RELATED DOCUMENTS4
 - 1.1 Installation Instructions4
 - 1.2 Range Planning4
 - 1.3 Radio Telegram Description4
 - 1.4 STM 350 module inside4
 - 1.5 Declaration of Conformity4
- 2 GENERAL DESCRIPTION5
 - 2.1 Basic Functionality5
 - 2.2 Technical Data6
 - 2.3 Environmental Conditions7
 - 2.4 Ordering Information7
 - 2.5 Physical Dimensions7
 - 2.6 Packaging Information – Single Unit Packaging9
 - 2.7 Packaging Information – Tray Packaging10
 - 2.8 Device Label11
- 3 FUNCTIONAL DESCRIPTION12
 - 3.1 Block Diagram12
 - 3.2 Measurement and Transmission Timing12
 - 3.3 Firmware Flow Chart13
 - 3.4 Teach-in to Receiver Unit13
 - 3.5 Commissioning and Mode Change14
 - 3.6 Radio Telegram Format, EEP16
 - 3.8 Storing the Rolling code counter17
- 4 Application Information18
 - 4.1 General Installation Instructions18
 - 4.2 Lighting Conditions18
 - 4.3 Installing Supplemental Battery (optional)20
 - 4.4 Transmission Range21
- 5 REGULATORY NOTES23
 - 5.1 ETHSA Market Approval for European Union (CE)23
 - 5.2 ETHSA Market Approval for United Kingdom (UKCA)23
 - 5.3 ETHSU Market Approval for US (FCC)24
 - 5.4 ETHSU Market Approval for CA (ISED)26

ETHSA / ETHSU
ENOCEAN TEMPERATURE AND HUMIDITY SENSOR

1 RELATED DOCUMENTS

This document describes set-up and operation of the ETHSx unit. Related documents are as follows:

1.1 Installation Instructions

The installation instructions are contained in the single-unit packaging box and can also be found on the product website of EnOcean ETHSx.

1.2 Range Planning

We recommend following our application notes, in particular AN001 "EnOcean Wireless Systems - Installation Notes" (PDF) available as download at:
www.enocean.com/en/application-notes/

1.3 Radio Telegram Description

ETHSx transmits radio telegrams according to EnOcean Equipment Profile EEP A5-04-03 (temperature & humidity measurement value), EEP SIGNAL 0x06 (Energy Level Reporting) and EEP SIGNAL 0x0E (Entering Transport Mode) as defined in the EnOcean Equipment Profiles specification:

www.enocean-alliance.org/eep/

If the device shall be operated in Secure Mode please refer to the EnOcean Security Specification:

www.enocean.com/security-specification

1.4 STM 350 module inside

User Manuals of the electronic modules inside of the ETHSx unit:

868 MHz: www.enocean.com/en/products/enocean_modules/stm-350

902 MHz: www.enocean.com/en/products/enocean_modules_902mhz/stm-350u

1.5 Declaration of Conformity

The Declaration of Conformity can be found on the EnOcean ETHSx product webpage.

ETHSA / ETHSU
ENOCEAN TEMPERATURE AND HUMIDITY SENSOR

2 GENERAL DESCRIPTION

This user manual specifies ETHSx units with Stepcode DE or later:

- See chapter "2.8 Product Label and QR Code" to find out the module stepcode.
- For a detailed description of product changes see Product Change Notification (PCN).
- The user manual for older modules can be downloaded from the product website (V2.1).

2.1 Basic Functionality

ETHSx is a wireless and maintenance free temperature & humidity sensor for EnOcean systems. It provides on-board a calibrated temperature and humidity sensor. Powered by a solar cell, it works absolutely maintenance-free. An integrated energy store allows operation for several days in total darkness. In dark surrounding, a battery can be retrofitted.

The small housing can easily be mounted to walls or furniture using the included adhesive pad or using the included wall plate.

Single unit pack only: With the included metal stand, the sensor can be positioned on horizontal surfaces. One end cap can be replaced by the enclosed triangle cap.

ETHSx periodically measures temperature and humidity of its environment. Significant changes in readings are reported immediately. In addition, frequent updates (signs-of-life) are provided at regular intervals. A teach-in telegram is triggered immediately using the LRN button. ETHSx provides the option to use Enhanced Security mode with encrypted communication and Rolling Code



ETHSx Key Product Features

- Fully autonomous operation under sufficient lighting with pre-installed solar cell (Battery backup option for operation in dark surroundings)
- Accessories included
 - Wall mounting plate
 - Double-sided adhesive
 - Metal stand and triangle cap for freestanding operation (single unit pack only)
- Small housing with
 - Factory calibrated on-board temperature and humidity sensor
 - Integrated energy storage and charging circuit
 - Integrated LRN button and TX indicator LED
- Enhanced Security feature

ETHSA / ETHSU ENOCHEAN TEMPERATURE AND HUMIDITY SENSOR

2.2 Technical Data

Primary power supply	Solar with indoor light, min. 50 lx
Auxiliary power supply	Option for backup battery (CR1225, not included)
Antenna	Internal helix antenna
Radio standard / frequency	ETHSA: EnOcean 868.300 MHz ETHSU: EnOcean 902.875 MHz
Data rate / modulation type	125 kbps / ETHSA = ASK, ETHSU = FSK
Radiated Output Power	ETHSA = typ. +5dBm ETHSU = typ. +99 dBμV/m
Temperature sensor performance	Measurement range: -20°C ... +60 °C Resolution: 0.1 K Accuracy: ±0.5 K across entire range
Humidity sensor performance	Measurement range: 0 % ... 100 % r.h. Resolution: 0.4 % r.h. Accuracy: ±4.5 % r.h. across entire range ±3.0 % r.h. between 20 ... 80 % r.h.
Measurement cycle time	Once every 100s
Immediate transmission threshold	Change by >±0.5 K or >±3% rh versus last transmission
Sign-of-life transmission	Measurement data update once every 11-24 minutes (by random)
Teach-in telegram trigger	Pushbutton behind hole inside housing
Teach-in telegram indicator	LED shining through housing
Start-up time with empty energy store	typ. < 2.5 min @ 400 lx, 22°C ¹⁾
Sustain condition for battery free operation	min. 1200 lxh per day (22°C)
Fully charged condition	6400 lxh (22°C)
Operation time in total darkness	> 10 days (energy storage fully charged, sign of live only, 22°C) ²⁾
Operation time with backup battery	5 years min. (total darkness, 22°C)
EnOcean module integrated	ETHSA: STM 350 for EU/UK with CE/UKCA ETHSU: STM 350U for US/CA with FCC/ISED
EnOcean Equipment Profile (EEP)	A5-04-03 SIGNAL 0x06 (Energy Level Reporting) SIGNAL 0x0E (Entering Transport Mode)

Note 1: Charging time from empty energy store until a teach-in telegram can be sent

Note 2: Operation time from a fully charged energy store if telegrams sent on average every 17.5 minutes (signs-of-life). To maintain the performance, please refer to chapter 2.3!

ETHSA / ETHSU ENOCAN TEMPERATURE AND HUMIDITY SENSOR

2.3 Environmental Conditions

Operating and Storage temperature	Absolute Maximum: -20 °C ... +60 °C Recommended ¹⁾ : +10 °C...+30 °C
Operating and storage humidity	Maximum: 0% ... 93% r.h., non-condensing Recommended: < 60% r.h.
Shelf life (in absolute darkness)	36 months after delivery in transport mode ²⁾

Note 1: Recommended for maximum life of energy storage capacitor. The following effects will lead to shorter dark time operation:

- a) Long time exposure of the unit to temperatures higher 30°C will gradually degrade the energy storage performance over lifetime.
- b) Lower temperatures than 10°C will noticeable reduce capacity of energy store, but temporarily only.

Note 2: Recharge energy storage after 36 months in total darkness. Deep discharge of the energy storage leads to degradation of performance. Therefore, the device must be put into operation after 36 months in transport mode.

2.4 Ordering Information

Type	Ordering Code	Frequency	Packaging
ETHSA	S3001-C350	868.300MHz	Single Unit Packaging (chapter 2.6)
ETHSA	S3001-T350	868.300MHz	Tray Packaging (chapter 2.7)
ETHSU	S3051-C350	902.875MHz	Single Unit Packaging (chapter 2.6)

2.5 Physical Dimensions

Colour of unit	White, similar to RAL 9010
Material of unit housing and mounting plate	PC-ABS (housing), POM (mounting plate)
Dimensions of unit without mounting plate (no stand, 2 square caps)	76.2 x 22 x 15 mm
Dimensions of unit with mounting plate	79 x 23.8 x 18.6 mm
Dimensions of unit with stand and triangle cap (single pack only)	30 x 30 x 85±1 mm
Dimensions of stand	30 x 30 x 1.2 mm (without slide-flap)
Dimensions of housing adhesive	50 x 18 x 0.8 mm

ETHSA / ETHSU
ENOCEAN TEMPERATURE AND HUMIDITY SENSOR

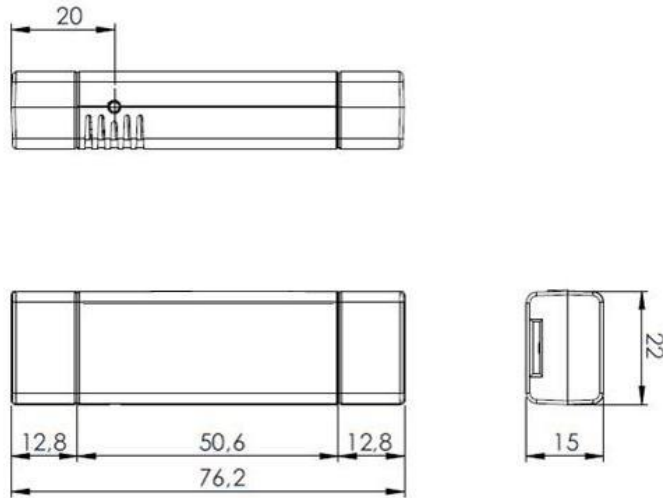

ETHSx Mechanical Outline (with 2 square caps, without stand)

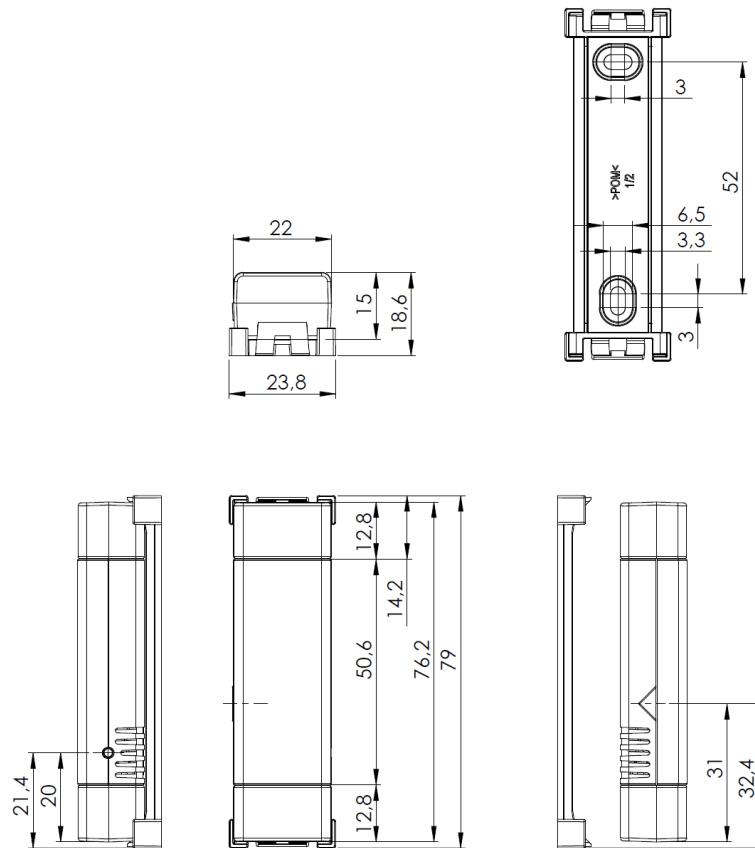

ETHSx Mechanical Outline (with mounting plate)

ETHSA / ETHSU
ENOCEAN TEMPERATURE AND HUMIDITY SENSOR

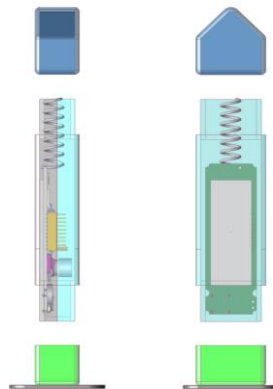

ETHSx Mechanical Outline (with triangle cap and stand)

2.6 Packaging Information – Single Unit Packaging

Content of single unit box:

1. TH Sensor Unit (wireless sensor in housing)
2. Mounting Plate (for mounting the sensor onto a wall)
3. Adhesive Tape (double-sided, for easy gluing the sensor onto a smooth surface)
4. Metal Stand (fixed to unit, removable)
5. Triangle Cap (separate in a little plastic bag)
6. Installation Instructions

Weight of sensor unit (with 2 square caps, without stand)	20 g
Weight of single unit box (sensor unit, stand, mounting plate, packaging)	43 g
Size of single unit card box	32 x 32 x 99 mm
Minimum order quantity (transport packaging)	50 units
Dimensions of transport card box (50 single unit boxes)	232 x 176 x 174 mm
Weight of transport box (including 50 single unit boxes)	2.3 kg

ETHSA / ETHSU
ENOCEAN TEMPERATURE AND HUMIDITY SENSOR



Content of single unit box:
TH Sensor Unit, Adhesive, Stand, Mounting plate, Triangle Cap, Instructions

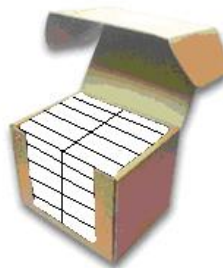

Transport packaging with 50 single unit boxes

2.7 Packaging Information – Tray Packaging

Card box with 7 plastic trays containing 8 sensor units each, plus 1 tub-tray for the accessories.

Content:

1. 56 TH Sensor Units
2. Mounting Plates (preinstalled at reed contact units)
3. Adhesive Tapes (in separate tray)
4. Magnets with adhesive tape (in separate tray)

Minimum order quantity (transport packaging)	56 units
Dimensions of transport box (56 units)	232 x 176 x 174 mm
Weight of transport box (56 units)	2.2 kg

ETHSA / ETHSU
ENOCEAN TEMPERATURE AND HUMIDITY SENSOR

2.8 Device Label

The structure of the ETHSx device label is shown in following Figure:

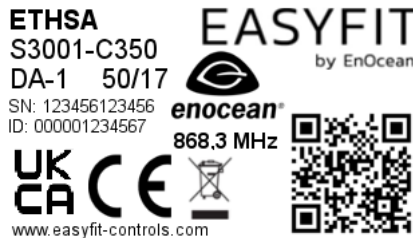

Figure: Unit Label

2.8.1 Step Code

The Step Code describes the functional product status of the device and can be found on the product label between the product ordering code and the unit’s serial number. In the upper figure the step code is “DA”.

2.8.2 QR-Code

In order to improve logistic and commissioning of the sensor unit a QR code can be found on the unit label. The QR code used in the new product label encodes the product parameter according to the ANSI/MH10.8.2-2013 industry standard.



Figure: QR Code Example

The QR code shown in the example figure above encodes the following string:
„30S000001234567+30PS3001-C350+2PDA01+S01123456123456“

The following table shows the interpretation of the data therein:

Identifier	Length of data excluding identifier	Value	Comment
30S	12 characters	ID, Static Source Address	hex
30P	10 characters	Ordering Code	“S3001-C350”
2P	4 characters	Step code and revision	“DA-01”
S	14 characters	Serial Number	

Table: QR Code content

3 FUNCTIONAL DESCRIPTION

3.1 Block Diagram

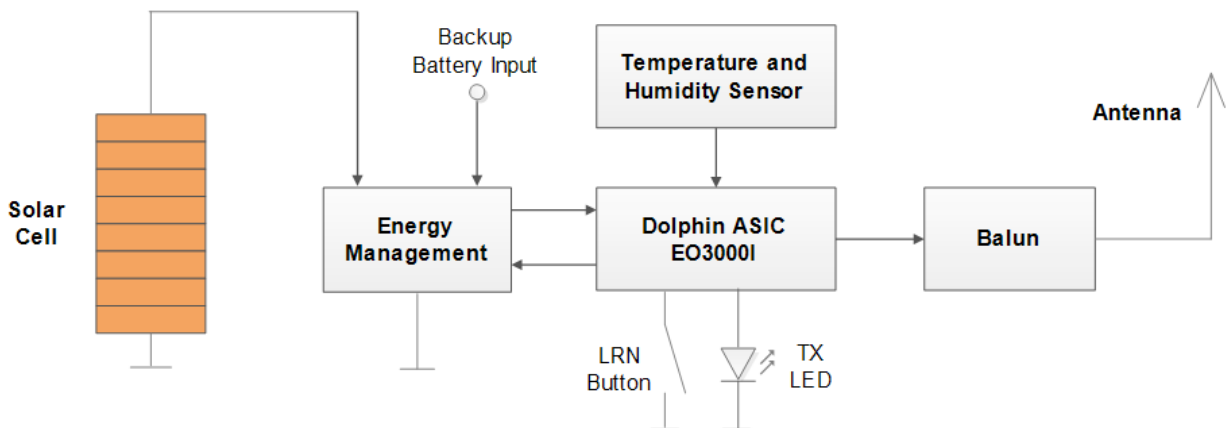

Figure: Hardware block diagram (simplified)

3.2 Measurement and Transmission Timing

ETHSx wakes up approximately once every 100 seconds to measure temperature and humidity. The measured values are then compared against the last reported (transmitted) values. If there is a significant change then the measured values are transmitted immediately. Significant change is defined as follows:

- Temperature: The measured temperature deviates from the last reported temperature by more than 0.5 K
- Humidity: The measured humidity deviates from the last reported humidity by more than 3% r.h.

In absence of a significant change, a heartbeat telegram reporting the currently measured values is transmitted for every 7 to 14 measurements (affected at random). In addition, ETHSx measures and reports the energy level of its internal energy storage element approximately every 100 measurements. With each default transmission cycle, 3 identical sub-telegrams are transmitted within 40ms. Transmission of a sub-telegram lasts approximately 1.2ms. The delay between the three transmission bursts is affected at random. This setup of the transmission timing allows avoiding possible collisions with data packages of other EnOcean transmitters as well as disturbances from the environment.

3.3 Firmware Flow Chart

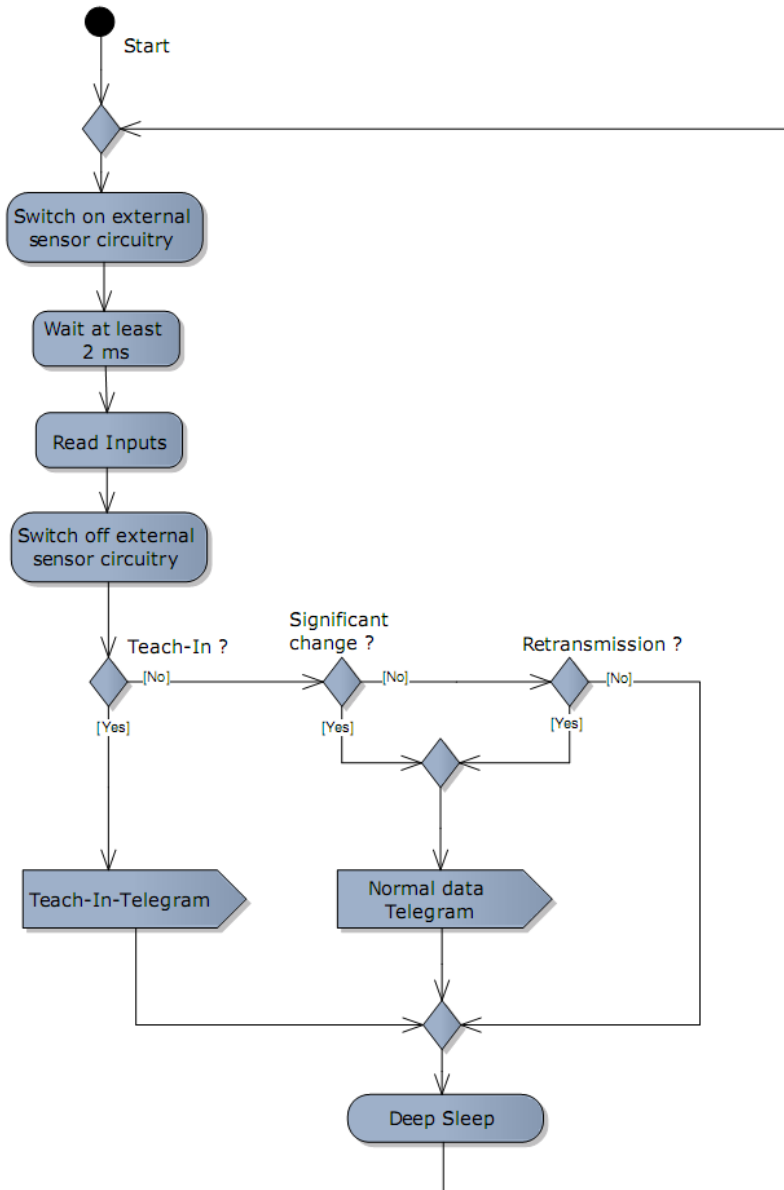

Figure: Firmware flow chart (simplified)

3.4 Teach-in to Receiver Unit

Push the button behind the hole in the side wall to trigger a teach-in telegram. You will see

ETHSA / ETHSU
ENOCEAN TEMPERATURE AND HUMIDITY SENSOR

a LED shining at the housing side as telegram indicator (pay attention to sufficiently dark environment).

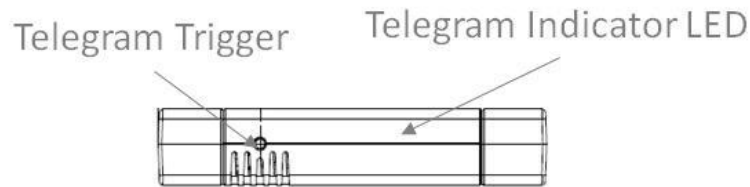

Figure: Teach-in telegram trigger

When pressing the LRN key, the module sends a teach-in telegram to a suited receiver according to the currently selected communication mode (4BS teach-in telegram for Standard Mode, secure teach-in telegram for Security Mode). The teach-in telegram identifies the device manufacturer and the function and type of the device via the EEP used. For EASYFIT devices, EnOcean is set as manufacturer with ID 0x00B.

3.5 Commissioning and Mode Change

The module is shipped in Transport Mode (Mode 3) to switch off the energy store for long term shelf storage and air cargo. The mode can be changed by pressing the learn button. Please note that the modes have been changed with Stepcode DE (and later). Make sure that the solar cell will get enough light for mode change and/or learn telegram.

■ **Change from Transport Mode to Standard Mode:**

After pressing learn button **1x short (around 1s)** the radio module will enter Standard Mode (Mode 1). **A standard learn telegram will be sent and the LED will flash 2x.**

■ **Change from Standard Mode to Secure Mode:**

After pressing learn button **2x long (2x around 5s, pause <1s)** the radio module will enter Secure Mode (Mode 2). **A secure learn telegram will be sent and the LED will flash 2x.**

■ **Change from Secure or Standard Mode to Transport Mode:**

After pressing learn button **1x long (around 5s)** the radio module will enter Transport Mode (Mode 3). **A signal telegram will be sent and the LED will flash 3x.**

The following diagram illustrates all implemented mode transitions:

ETHSA / ETHSU ENOCEAN TEMPERATURE AND HUMIDITY SENSOR

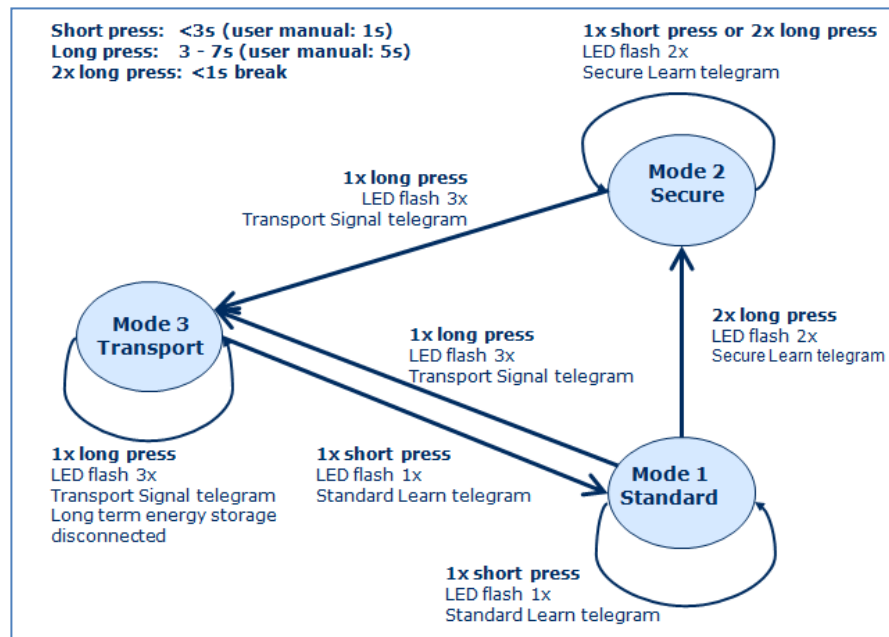

Figure: Mode Transitions

The following pushbutton timing is implemented:

- Short press: **around 1s** (firmware 0.1 – 3.0 s)
- Long press: **around 5s** (firmware 3 – 7 s)
- 2x long press with very short pause of max. 1 s between



Before changing the operating mode please make sure to clear the device from all receivers which have been taught to work with this device before. Otherwise the receiver will ignore the telegrams and the application will not work.



The flag for actual mode itself is stored in non-volatile memory. After power down reset the previous selected mode is active. The mode change is limited to 50 times. In normal application scenario only very few are required.

3.6 Radio Telegram Format, EEP

3.6.1 Standard Mode

ETHSx transmits a radio telegram according to EnOcean Equipment Profile EEP A5-04-03 as defined in the EEP EnOcean Equipment Profiles specification:

www.enocean-alliance.org/eep/

3.6.2 Secure Mode and Secure Telegram

In Secure Mode the payload content of the telegram is protected with advanced security features. Normal operation telegram payload and also Teach-in telegram payload both are protected in the same way. The security features used are defined by the Security Level format - SLF. This parameter is set by default to following values (Stepcode DE and later):

- 24-bit RLC which starts from 0 at production
- RLC sent explicitly
- 3-byte CMAC
- VAES encryption

The security features are added to the communication by encapsulating the payload and Teach-in telegram payload into a secured telegram. The payload itself is not changed and corresponds to the standard mode payload like defined by EEP D5-00-01. Please refer to the EnOcean Security Specification for details:

<http://www.enocean.com/en/security-specification/>.

3.6.3 Secure Learn Telegram

In standard mode an 1BS teach-in telegram is transmitted by pressing the LRN button. To process secured communication on a receiver the ETHSx has to send a security teach-in telegram to the receiver and so inform him about the used security profile, AES key and initial RLC counter. The security teach-in has to take place before any other communication can be executed (profile teach-in included). Press the LRN button to trigger the transmission of the teach-in telegram. The security teach-in and then the profile teach-in are transmitted. The profile teach-in telegram is already protected by advanced security features. The process of sending security teach-in telegram and profile teach-in telegram is triggered by pressing the LRN button in secure mode, the behaviour of the LRN button is following:

1. Button is pressed
2. Security teach-in is send.
3. Profile teach-in is send.

For more information on the structure of the teach-in telegram please refer to chapter 4.2 of the EnOcean Security Specification: www.enocean.com/security-specification

ETHSA / ETHSU
ENOCEAN TEMPERATURE AND HUMIDITY SENSOR

3.7 Radio Telegram Timing

The setup of the ETHSx transmission timing reliably avoids possible collisions with data packages of other EnOcean transmitters as well as disturbances from the environment.

3.7.1 Standard Mode Transmission Timing

In Standard Mode with each transmission cycle, 3 identical subtelegrams are transmitted within 40 ms. Transmission of a subtelegram lasts approximately 0.9 ms. The delay between the three transmission bursts is affected at random.

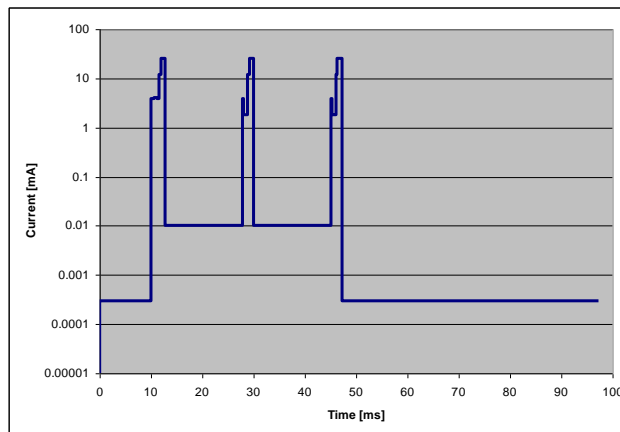

Figure: Transmission timing in Standard Mode

3.7.2 Secure Mode Transmission Timing

In Secure Mode the transmission cycle is reduced to 2 identical subtelegrams that are transmitted within 20 ms. This compensates the additional energy requirement of enhanced security computing and additional payload. The transmission of a subtelegram lasts approximately 1.2 ms.

3.8 Storing the Rolling code counter

For the enhanced security features a RLC counter needs to be stored in non-volatile memory. For security reasons the RLC counter is incremented by every transmitted telegram. Together with the CMAC the RLC ensures that messages cannot be reproduced or forged.

The RLC is stored in the Dolphin chip flash memory. To improve the endurance of the flash memory and also the energy budget not every increment is saved to the non-volatile flash memory. During deep sleep the RLC is stored in RAM0 memory.

4 Application Information

4.1 General Installation Instructions

The small sensor housing can easily be mounted to walls or furniture using the included double-sided adhesive pad. Using the included metal stand the sensor can be positioned on horizontal surfaces. One end cap can be replaced by the enclosed triangle cap. To mount the sensor to walls with uneven ground, for example rough plaster, the sensor can be fixed by the enclosed mounting plate that was previously fastened to the wall by screws.



To achieve the desired measurement result, avoid direct sunlight on the device and do not place the device close to HVAC units or similar.

Further important installation notes please find in the Installation Instructions provided together with the unit.

4.2 Lighting Conditions

4.2.1 Minimum Illumination

- **1200 lxh per day** is the minimum illuminance over time of the solar panel that has to be ensured in order to recharge the device for night operation
- lxh (lux hours) is the multiplication value between illuminance (lux) and time (hours). This value can roughly be taken as a constant at illuminances greater than 100 lx: e.g. 200 lx illumination for 6 hours equals 400 lx for 3 hours
- The value applies to daylight, artificial light and mixed light. Define the minimum brightness and duration in worst case (averaged over the day). Check the long-term lighting conditions at the intended location of the device under the most unfavorable conditions (e.g. winter time)

4.2.2 Local Lighting Conditions

- Brightness values are highly dependent on the site. Typical values for room type and placement within a room can be found in the following table and figure. **The given numbers are reference values only.** Please use an illuminometer (lux meter) to verify a particular case. Suited lux meters are available from € 25 upwards from internet shops.
- If possible the unit should be mounted with the solar cell facing the window, but avoiding direct sunlight. With regard to the future use of the room, the installation site should be chosen so that it cannot be shaded by the user (eg filling cabinets).
- Determine the best compromise position between the best illuminance and the location requirements of the sensor. A place that is not sufficiently illuminated during the day should be avoided or, if not possible, a CR 1225 battery can be retrofitted.

ETHSA / ETHSU ENOCEAN TEMPERATURE AND HUMIDITY SENSOR

Illumination Area	Type Destination / Workspace	Typical Brightness
Home	Usually	100 – 500 lx
Schools	Corridor	100 – 300 lx
	Classroom in general	300 – 750 lx
	Reading room, laboratory	500 – 1500 lx
Offices	PC room, working at PC	200 – 500 lx
	Meeting room	300 – 700 lx
	Canteen	150 – 300 lx
	Corridors	50 – 100 lx
	Reception	300 – 700 lx
Factories	Restroom	100 – 300 lx
	Production hall	500 – 1500 lx
	Development, office	300 – 750 lx
	Design CAD	500 – 1500 lx
	Laboratory, inspection work	750 – 1500 lx
	Packaging of products	150 – 500 lx
Hospitals	Storage	100 – 300 lx
	Visitor room	300 – 500 lx
	First aid, surgery	500 – 1500 lx
	Bedroom	100 – 300 lx
	Pharmacies	500 – 1000 lx
Hotels	Wash rooms	150 – 300 lx
	Reception	200 – 500 lx
	Entrance area	100 – 300 lx
	Restaurant	150 – 300 lx
	Restroom	100 – 300 lx
	Bars	50 – 150 lx
	Corridors	50 – 100 lx
	Staircases	50 – 150 lx
Stores	Saleroom	300 – 1000 lx
	Show room	500 – 1500 lx
	Packaging area	200 – 300 lx
	Lounge	300 – 500 lx
Trade Show	Conference room	300 – 700 lx
	Booth	300 – 500 lx
Sports Arena	Indoor area	200 – 500 lx

Table: Typical Indoor Brightness Levels (Lux)

ETHSA / ETHSU
ENOCEAN TEMPERATURE AND HUMIDITY SENSOR

Figure: Examples of brightness levels at different spots in a typical office room (worktable $E_A=500 \text{ lx}$)

4.2.3 Initial Sensor Operation

To reach full performance the solar-powered energy storage must be recharged after a long storage in dark (eg at initial installation). This is done automatically from the beginning of operation in the light and the sensor will reach its full operating state after 3 to 4 days. Then the sensor will have enough energy to work in dark the whole weekend.

4.3 Installing Supplemental Battery (optional)

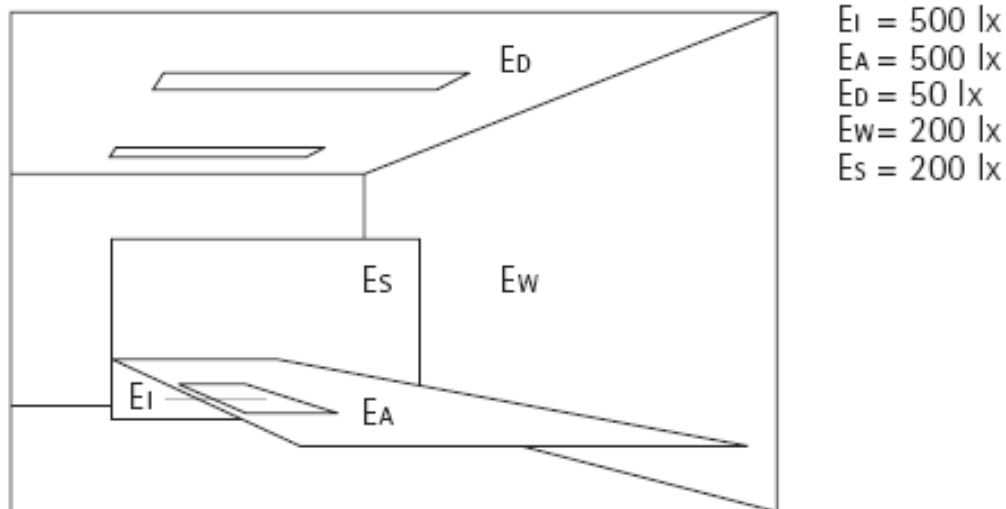
If the sensor is installed where the light levels are consistently too low, battery power can be used to supplement the solar energy harvester. Use CR1225 battery only.

1. Pull off the cap which rests directly at the solar cell.
2. Insert the battery with the larger positive pole (+) directed to the solar cell and slide it between the two contact terminals (see following figure).
3. Put the cap back on.

NOTE: It is strongly recommended to wear protective gloves while handling coin cell batteries. Failure to do so might result in the formation of a conductive layer on the battery surface due to skin moisture and a much shorter battery lifetime.



WARNING: Ensure the battery is properly oriented. Improper handling of lithium batteries may result in heat generation, explosion, or fire.

**ETHSA / ETHSU
ENOCHEAN TEMPERATURE AND HUMIDITY SENSOR**

Figure: Properly inserted battery

4.4 Transmission Range

Mounting the sensor housing with his backside on metal surfaces will reduce the transmission range. Therefore please note that a radio receiver unit should not be mounted in the same plane as the metal surface, because in extension of the metal surface the transmission range is reduced by physical radio transmission effects of the antenna near to metal. For example the receiver should not be mounted at the same wall side.

The main factors that influence the system transmission range are type and location of the antennas of the receiver and the transmitter, type of terrain and degree of obstruction of the link path, sources of interference affecting the receiver, and “dead” spots caused by signal reflections from nearby conductive objects. Since the expected transmission range strongly depends on this system conditions, range tests should categorically be performed before notification of a particular range that will be attainable by a certain application. The following figures for expected transmission range may be used as a rough guide only:

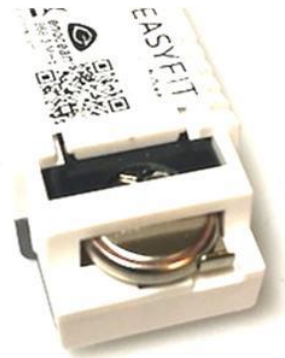
- Line-of-sight connections: Typically 30 m range in corridors, up to 100 m in halls
- Plasterboard walls / dry wood: Typically 30 m range, through max. 5 walls
- Ferroconcrete walls / ceilings: Typically 10 m range, through max. 1 ceiling
- Fire-safety walls, elevator shafts, staircases and supply areas should be considered as screening.

The angle at which the transmitted signal hits the wall is very important. The effective wall thickness – and with it the signal attenuation – varies according to this angle. Signals should be transmitted as directly as possible through the wall. Wall niches should be avoided. Other factors restricting transmission range:

- Switch mounted on metal surfaces (up to 30% loss of transmission range)

ETHSA / ETHSU
ENOCHEAN TEMPERATURE AND HUMIDITY SENSOR

-
- Hollow lightweight walls filled with insulating wool on metal foil
 - False ceilings with panels of metal or carbon fiber
 - Lead glass or glass with metal coating, steel furniture

The distance between EnOcean receivers and other transmitting devices such as computers, audio and video equipment that also emit high-frequency signals should be at least 0.5 m.

A summarized application note to determine the transmission range within buildings is **AN001 "EnOcean Wireless Systems - Installation Notes"** (PDF) available as download from: www.enocean.com/en/application-notes/

ETHSA / ETHSU
ENOCHEAN TEMPERATURE AND HUMIDITY SENSOR

5 REGULATORY NOTES**5.1 ETHSA Market Approval for European Union (CE)**

Hereby, EnOcean GmbH declares that the radio equipment ETHSA is in compliance with the essential requirements and other relevant provisions of Radio Equipment Directive 2014/53/EU (RED). A copy of the Declaration of Conformity can be obtained from the product webpage. The OEM customer (B2B) is responsible for country specific local documentation.

Waste & Battery:

WEEE-Reg-No.: DE 93770561

UBA Reg-No.: 21008516

Since the European Union requires country specific recycling, for all other countries than Germany the OEM customer (B2B) must register at country specific recycling organizations.

5.2 ETHSA Market Approval for United Kingdom (UKCA)

Till end of 2022 UK will accept EU (CE) market approval (see above). From 2023 UK will introduce its own market approval system, which is derived from the EU CE (EU directives will be UK statutory instruments, EU standards will be British standards). EnOcean will provide the UK declaration of conformity (UK DoC) document at the product website for download.

The final product package including EnOcean ETHSA must meet all necessary application specific requirement for UK conformity (e.g., building automation application, UK WEEE registration and documentation with UKCA). The OEM customer (B2B) is responsible for the final product documentation and must register at UK specific recycling organizations.

ETHSA / ETHSU
ENOCEAN TEMPERATURE AND HUMIDITY SENSOR

5.3 ETHSU Market Approval for US (FCC)

FCC Certificate

TCB

GRANT OF EQUIPMENT
AUTHORIZATION

Certification
Issued Under the Authority of the
Federal Communications Commission
By:

TCB

Timco Engineering, Inc.
849 NW State Road 45
P.O. Box 370,
Newberry, FL 32669

Date of Grant: 01/30/2018
Application Dated: 01/30/2018

EnOcean GmbH
Kolpingring 18a
Oberhaching, 82041
Germany

Attention: Armin Anders , Director Product Marketing

NOT TRANSFERABLE

EQUIPMENT AUTHORIZATION is hereby issued to the named GRANTEE, and is VALID ONLY for the equipment identified hereon for use under the Commission's Rules and Regulations listed below.

FCC IDENTIFIER: SZV-STM350U
Name of Grantee: EnOcean GmbH
Equipment Class: Part 15 Security/Remote Control Transmitter
Notes: Temperature and Humidity Sensor with transmitter

<u>Grant Notes</u>	<u>FCC Rule Parts</u>	<u>Frequency Range (MHZ)</u>	<u>Output Watts</u>	<u>Frequency Tolerance</u>	<u>Emission Designator</u>
	15.231	902.875 - 902.875			

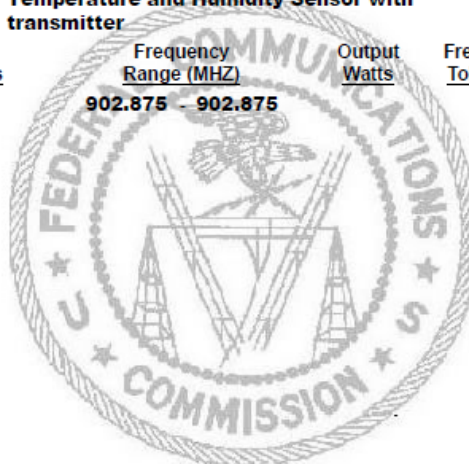

FCC Regulatory Statement

The ETHSU device complies with part 15 of the FCC Rules. Operation is subject to the following two conditions:

ETHSA / ETHSU
ENOCHEAN TEMPERATURE AND HUMIDITY SENSOR

- (1) this device may not cause harmful interference, and
- (2) this device must accept any interference received, including interference that may cause undesired operation

FCC Usage Conditions

STM 350U is a RF module approved for Single Modular use. It is incorporated into ETHSU as OEM installation using an approved antenna.

The module is optimized to operate using small amounts of energy, and may be powered by a battery. The module transmits short radio packets comprised of control signals, (in some cases the control signal may be accompanied with data) such as those used with alarm systems, door openers, remote switches, and the like.

The module does not support continuous streaming of voice, video, or any other forms of streaming data; it sends only short packets containing control signals and possibly data. The module is designed to comply with, has been tested according to 15.231(a-c), and has been found to comply with each requirement.

Thus, ETHSU containing the STM 350U radio module can be operated in the United States without additional Part 15 FCC approval (approval(s) for unintentional radiators may be required for the OEM's finished product), under EnOcean's FCC ID number if the OEM requirements are met.

FCC OEM Requirements

In order to use EnOcean's FCC ID number, the OEM must ensure that the following conditions are met:

- The Original Equipment Manufacturer (OEM) must ensure that FCC labeling requirements are met. This includes a clearly visible label on the outside of the final product. Attaching a label to a removable portion of the final product, such as a battery cover, is not permitted.

- The label must include the following text:

Contains FCC ID: SZV-STM350U

The enclosed device complies with Part 15 of the FCC Rules. Operation is subject to the following two conditions: (i.) this device may not cause harmful interference and (ii.) this device must accept any interference received, including interference that may cause undesired operation.

- The FCC identifier or the unique identifier, as appropriate, must be displayed on the device.

- The user manual for the end product must also contain the text given above.

ETHSA / ETHSU
ENOCEAN TEMPERATURE AND HUMIDITY SENSOR

5.4 ETHSU Market Approval for CA (ISED)

ISED Certificate

TIMCO ENGINEERING INC.

849 NW State Road 45
Newberry, Florida 32669
<http://www.timcoengr.com>
888.472.2424 F 352.472.2030 email: cb@timcoengr.com

No. ➤ 83IC18

**TECHNICAL ACCEPTANCE
CERTIFICATE**

Certification No. ➤ IC: 5713A-STM350U

Issued To ➤ EnOcean GmbH
Kolpingring 18A,
Oberhaching, 82041, Germany

Tested By ➤ VPI LABORATORIES, INC.
Company No: 2041A
29145 Old Lincoln Hwy,
Wanship, Utah 84017 USA
801-260-4056; 866-307-0033
joej@vpitech.com

Type of Equipment ➤ Low Power Device (902-928 MHz)

Type of Service ➤ New Certification (Single)

Hardware Version Id Number (HVIN) ➤ STM 350U

Product Marketing Name: (PMN) ➤ STM 350U

Firmware Version Id Number (FVIN) ➤ N/A

Host Marketing (HMN) ➤ N/A

FREQUENCY RANGE	EMISSION DESIGNATIONS <small>NECESSARY BANDWIDTH & EMISSION CLASSIFICATION</small>	R.F. POWER	ANTENNA INFO	SPECIFICATION / ISSUE & DATE
902.875 MHz	342KF1D	80.3 dBuV/@ 3m	Helical 0 dBi	RSS-210 Issue 9; Aug 16

Note1: This equipment also complies with RSS-102, Issue 5 (March 2015) and RSS-Gen, Issue 4 (Nov 2014)

Certification of equipment means only that the equipment has met the requirements of the above noted specifications. License applications, where applicable to use certified equipment, are acted on accordingly by the issuing office and will depend on the existing radio environment, service and location of operation.

La certification du matériel signifie seulement que le matériel a satisfait aux exigences de la norme indiquée ci-dessus. Les demandes de licences nécessaires pour l'utilisation du matériel certifié sont traitées en conséquence par le bureau de délivrance et dépendent des conditions radio ambiantes, du service et de l'emplacement d'exploitation.

This certificate is issued on condition that the holder complies and will continue to comply with the requirements of the radio standards specifications and procedures issued by Industry Canada.

Le présent certificat est délivré à la condition que le titulaire satisfasse et continue de satisfaire aux exigences et aux procédures d'Industrie Canada.

I hereby attest that the subject equipment was tested and found in compliance with the above-noted specifications.

J'atteste par la présente que le matériel a fait l'objet d'essai et jugé conforme à la spécification ci-dessus.

ISSUED UNDER THE AUTHORITY OF MINISTER OF INDUSTRY
DÉLIVRÉ AVEC L'AUTORISATION DU MINISTRE DES INDUSTRIES

Bruno Clavier, General Manager

DATE: January 31, 2018

ETHSA / ETHSU
ENOCEAN TEMPERATURE AND HUMIDITY SENSOR**ISED Regulatory Statement**

The ETHSU device contains the EnOcean module STM 350U that complies with Industry Canada license-exempt RSS standard(s). Operation is subject to the following two conditions:

- (1) this device may not cause interference, and
- (2) this device must accept any interference, including interference that may cause undesired operation of the device.

Le présent appareil est conforme aux CNR d'Industrie Canada applicables aux appareils radio exempts de licence. L'exploitation est autorisée aux deux conditions suivantes:

- (1) l'appareil ne doit pas produire de brouillage, et
- (2) l'utilisateur de l'appareil doit accepter tout brouillage radioélectrique subi, même si le brouillage est susceptible d'en compromettre le fonctionnement."